

▶ PMC/XMC Module Carriers

APCe8675 PCI Express Carrier Card for XMC Modules

24 HOUR STOCK ITEM
2 YEAR WARRANTY

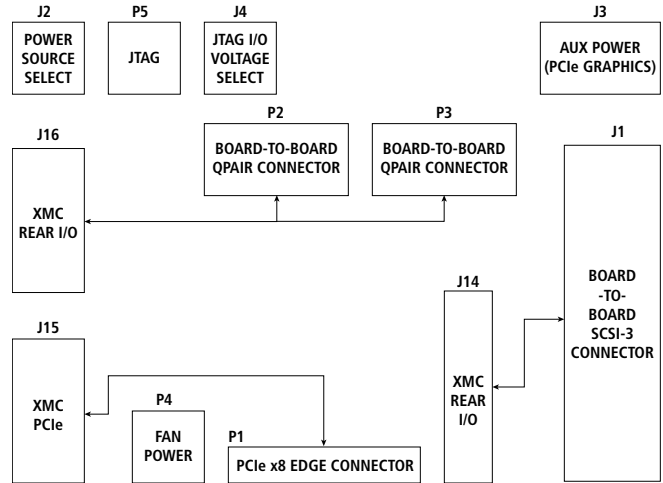

One XMC mezzanine module slot ◆ Non-Intelligent carrier card ◆ PCIe x8 interface

Description

Acromag's APCIe8675 carrier card interfaces an XMC mezzanine module to a PCI Express bus in a PC-based desktop computer system.

The APCIe8675 is a PCIe bus adapter board that allows a PC (PCIe bus master) to control and communicate with the hosted XMC module. It simply acts as an adapter to route signals between the system's PCIe bus and the XMC module connector.

The I/O signals are accessible via rear connectors and through the front mounting bracket. To simplify wiring, Acromag offers cables to connect the carrier's rear I/O signals to other carrier cards in adjacent slots. Cables are also available to connect the carrier's rear I/O to a front panel connector in an adjacent slot.

Select XMC modules from Acromag's offering of high-performance FPGA and I/O solutions or use any third-party ANSI/VITA 42 compliant mezzanine modules.

Key Features & Benefits

- One XMC module slot
- 8-lane PCI Express interface
- Cooling fan
- Supports high-speed serial interface between neighboring cards using protocols such as XAUI or Aurora
- Routes 32 differential pairs to rear connector for LVDS I/O from the XMC module
- JTAG programming connector supports Xilinx programmer for use in with hosted FPGA modules
- Auxilliary power connection for 12V source

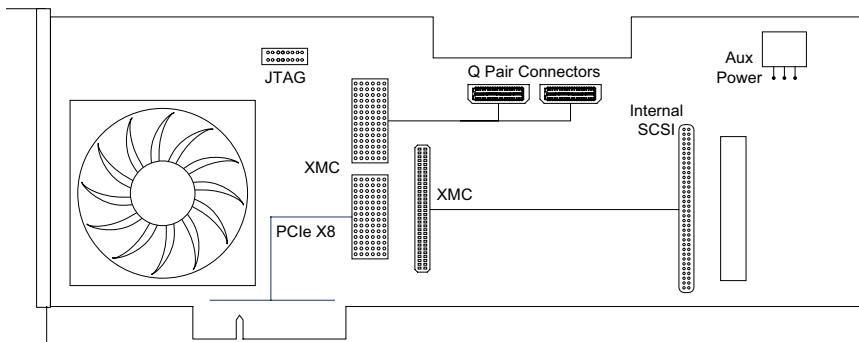

Acromag 
THE LEADER IN INDUSTRIAL I/O

Tel 248-295-0310 ■ Fax 248-624-9234 ■ solutions@acromag.com ■ www.acromag.com ■ 30765 Wixom Rd, Wixom, MI 48393 USA

PMC/XMC Module Carriers

APCe8675 PCI Express Carrier Card for XMC Modules

Performance Specifications

■ XMC Compliance

XMC Module
Complies with ANSI/VITA 42.0-2008.

■ I/O Interface

Serial Rear I/O (P2, P3)
Connector: Samtec QSH-DP 0.50 mm Q Pairs® high speed ground plane socket strip, differential pair.
These ports provide the ability to connect to left and right neighbor carrier cards using high speed serial protocols such as XAU1 or Aurora.
Supports up to five transmit and five receive high speed (5Gb/s) differential pairs or five LVDS pairs when used with Samtec QPairs® High Speed Twinax cables.

Rear I/O (J1)

Connector: MD68 (internal SCSI), male.
32 LVDS pairs routed from the XMC P4 connector.

■ PCI Express Interface

PCI Express interface
8 lane, Gen 1 capable.

PCIe bus compliance

This device meets or exceeds all written PCI Express specifications per revision 1.1 dated March 28, 2005.

■ Environmental

Operating temperature
0 to 70°C.

Storage temperature
-55 to 125°C.

Relative humidity
5 to 95% non-condensing.

Power

The carrier provides +3.3V, +12V and -12V power to the XMC module. The +12V power source is jumper-selectable from the PCIe bus +12V supply or the PCIe graphics power connector. The DC/DC converter generates a -12V supply from the +12V source.

+3.3V (±10%): 0mA.

+12V (±5%): 270mA, typical with fan operating.

Currents specified are for the carrier board only. For the total current required from each supply, add the XMC module currents.

MTBF

Contact the factory.

■ Physical

Dimensions

Length: 12.283 inches (312.0 mm).

Height: 4.200 inches (106.68 mm).

Width: Occupies two slots with fan installed (fan is mounted on solder side, height is 10 mm). Occupies one slot with fan removed.

Board thickness: 0.062 inches (1.59 mm).

Connectors

J1: Board-to-board connection of J14 user signals.

J2: Power source select jumper.

J3: Auxiliary power connector (PCIe graphics).

J4: JTAG I/O voltage select jumper.

J14, J16 : XMC user signals (rear I/O).

J15: XMC PCIe signals.

P1: PCI Express V1.1 x8 lanes card edge.

P2, P3: Board-to-board connection of J16 user signals.

P4: Fan power.

P5: JTAG (Xilinx programming adapter).

Ordering Information

Carrier Cards

APCe8675
PCI Express carrier card for XMC modules

Accessories

5025-917

Samtec Q Pairs® high speed twinax cable for board-to-board connections. 3 inches long, 20 differential pairs. Connects carrier cards in adjacent slots between P2 or P3 connectors. High-speed serial signals originate from XMC J16 rear I/O.

5025-913

CS Electronics internal SCSI cable with PCI bracket-mounted HD68 female connector. Brings the XMC J14 rear I/O signals to back panel of the PC.

XMC Modules

See www.acromag.com for more information.

ISO9001
AS9100

MADE IN USA

THE LEADER IN INDUSTRIAL I/O

Tel 248-295-0310 ■ Fax 248-624-9234 ■ solutions@acromag.com ■ www.acromag.com ■ 30765 Wixom Rd, Wixom, MI 48393 USA