

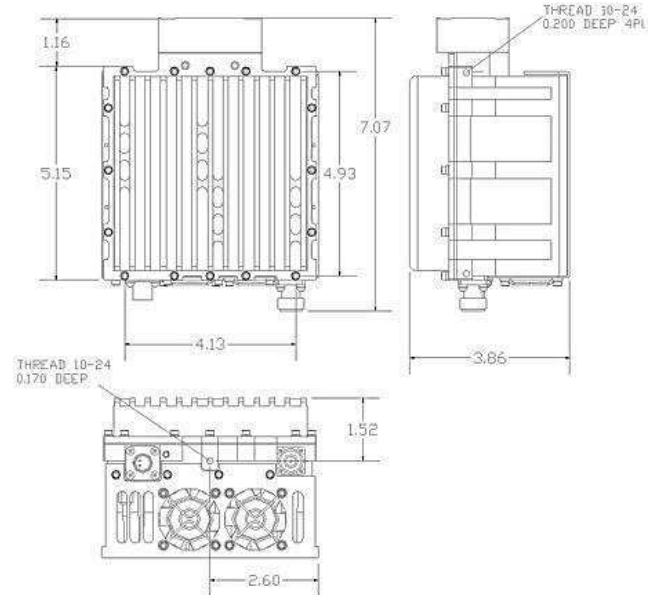

16W / 20W / 25W GaN-based X-Band BUC
SSPBg-210X™ series

Designed to meet MIL-STD-188-164A

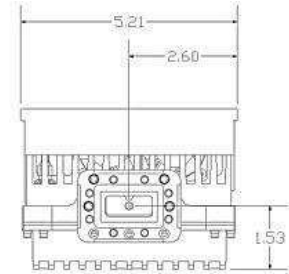

Features

- Up-converts an L-Band input frequency 950 – 1450 MHz to the X-Band frequency of 7.9 – 8.4 GHz
- Rated Output Power from 16W to 25W
- Phase-locked local oscillator locks directly to an external 10 MHz reference
- Exceeds IESS 308/309 Phase/Noise requirements by 3 dB
- Robust, weatherproof package
- Protection against thermal runaway and out-of-lock conditions
- Designed to meet MIL-STD-188-164A

Overview

The SSPBg-210X™ series is hub-mount up-converter transmitters, using GaN Technology, operating in the X-Band. The SSPBg-210X™ is an integrated unit, complete with power supply, phase-locked oscillator, mixer, filter and cooling mechanism. Intended for outdoor operation, the SSPBg-210X™ provides the utmost in convenience and efficiency. Other SSPBs are also available for higher powers or for operation at other up-link frequencies.

The hub-mount SSPBg-210X™ is constructed in a compact cooling enclosure for outdoor operation. The units are weatherproof. They are the smallest fully integrated units on the market today.

The design of these units is based on Advantech's industry proven reliable solid-state high power amplifiers. Built-in design features result in a product with exceptional linearity and operating efficiency. The use of high efficiency power supply and conservative thermal designs contribute to the trouble-free operation of the unit.

Application

The SSPBs convert an L-Band signal (950 - 1450 MHz) to the X-band frequency of 7.9 – 8.4 GHz. Designed for X-Band satellite up-link applications the SSPBg-210X™ series is fully integrated units with up to 25W output power designed for mounting outdoors, near the hub of an antenna.

The size and weight of this very compact design makes is especially attractive for man-pack terminal applications.

X-Band SSPBs are available in output power of up to 1000W.

Accessories

- Mounting kit
- Rx Reject filter

16W / 20W / 25W X-Band Block Up Converter



Technical Specifications	16W	20W	25W
Electrical Characteristics			
Rated Output power	+42.0 dBm typ.	+43.0 dBm typ.	+44.0 dBm typ.
Linear Output power	+38.0 dBm min.	+39.0 dBm min.	+40.0 dBm min.
Conversion gain min.	+63 dB		
Input /Output frequency range	950-1450 MHz/X-Band 7.9 – 8.4 GHz		
Input Level	-22 dBm for rated output power		
Gain flatness	3.0 dB p-p, typical over 500 MHz, 1.0 dB p-p /40 MHz		
Gain variation over temperature	3.0 dB p-p max over full operating range		
Input VSWR, in-band	1.5: 1		
Output VSWR	1.5: 1		
Input impedance	50 Ω		
Noise Power Density in Rx Band	-110 dBm/Hz max without external Rx Reject Filter		
Spurious at rated power	-55 dBc, max		
AM/PM conversion	1 °dB at linear power		
Spectrum Regrowth	-25 dBc, max at linear output power @ 1.0 symbol rate for QPSK/OPQSK/8PSK modulation		
Local Oscillator frequency (LO)	6.950 GHz		
LO leakage	-20 dBm max		
Phase noise	-55 dBc/Hz at 10Hz -73 dBc/Hz at 1000Hz -105 dBc/Hz at 100 kHz	-65 dBc/Hz at 100Hz -83 dBc/Hz at 10 kHz -110 dBc/Hz at 1 MHz	
Integrated (SSB) Phase Noise	2° RMS typical		
Group Delay (over any 40 MHz):	Linear Parabolic Ripple	0.03 ns /MHz, max 0.01 ns/MHz ² , max 1 nsec p-p, max	
External reference			
Reference frequency	10 MHz		
Recommended reference frequency phase noise	-115 dBc/Hz at 10 Hz -135 dBc/Hz at 100 Hz -148 dBc/Hz at 1000 Hz	-150 dBc/Hz at 10 kHz -160 dBc/Hz at 100 kHz	
Reference frequency level	0 dBm ± 5 dB		
Power Requirements			
Supply voltage	18 V to 75 V DC via L-band connector		
Power consumption (nominal)	95W		115W
Mechanical Characteristics			
Cooling	Mini-fan		
Dimensions (L x W x H)	17.95 x 13.23 x 9.8 cm (7.07" x 5.21" x 3.86")		
Weight	2.5 kg (5.5 lbs)		
Finish	White (option NATO Green)		
Interfaces:	RF input Type N (F) RF output CPR112 grooved / Type N (F) optional		
Environmental Conditions			
Temperature:	Operating	-30 °C to +55 °C option -40 °C to +55 °C	
	Storage	-55 °C to +85 °C	
Humidity	100%, condensing		
Altitude	10,000' AMSL, de-rated 2 °C/1,000' from AMSL		

NORTH AMERICA
USA
Tel: +1 703 659 9796
Fax: +1 703 635 2212
info.usa@advantechwireless.com

CANADA
Tel: +1 514 420 0045
Fax: +1 514 420 0073
info.canada@advantechwireless.com

EUROPE
UNITED KINGDOM
Tel: +44 1480 357 600
Fax: +44 1480 357 601
info.uk@advantechwireless.com

RUSSIA & CIS
Tel: +7 495 971 59 18
info.russia@advantechwireless.com

INDIA
Tel: +91 33 2415 5922
info.india@advantechwireless.com

SOUTH AMERICA
Tel: +1 514 420 0045
Fax: +1 514 420 0073
info.latam@advantechwireless.com

BRAZIL
Tel: +55 11 3054 5701
Fax: +55 11 3054 5701
info.brazil@advantechwireless.com

An ISO 9001 : 2008 Company



Ref.: PB-SSPBmg-16W-20W-25W-X-25-13178