

8W to 500W
ARM-K® series

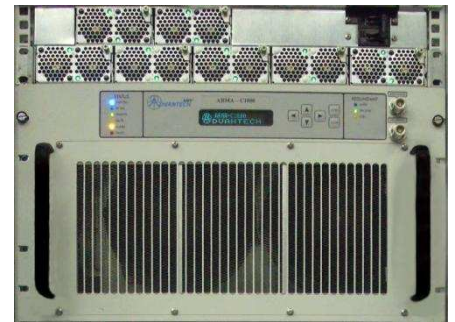

Features

- Full range of output power from 8W to 500W
- High linearity
- Redundant ready with no external controller
- Full M&C capability via RS485 or Ethernet port
- Forward and Reflected power monitoring
- Output Sample Port
- Redundant Systems shipped fully tested
- Infinite VSWR protection with automatic high reflected power shutdown
- Built-in Receive Reject Filter
- Power factor correction
- CE marking

Overview

Advantech AMT Ku-Band line of Amplifiers and BUCs are intended for satellite up-link applications. The design of these units is based on Advantech's proven techniques resulting in high linearity and operating efficiency. Conservative thermal design contributes to the high MTBF for these units. Full monitor and control is provided via the serial or Ethernet ports. Special features such as automatic over-temperature shutdown and high-reflected power protection contribute to a trouble free operation.

Advantech also offers the SUMMIT modular SSPA system for either indoor or outdoor applications.

The full set of accessories made available will facilitate the integration of these units in any application.

The ARM-K series 19" rackmount SSPA/SSPB (BUC) is available in output power from 16W to 500W. Higher power operation may be provided using external phase combining techniques offering an output power up to 800W.

Please contact factory for more details.

Options

- 1:1 or 1:2 Redundant configuration
- Phase combined systems for higher power
- L-Band input (SSPB/BUC operation)
- SNMP interface

Accessories

- Mounting slides
- Remote M&C panel

Redundancy

Advantech AMT Ku-Band line of Amplifiers and BUCs may be configured to operate in 1:1 or 1:2 redundancy mode. No extra controller is required for the redundancy operation as the built-in controller in each unit provides this function. For 1:1 redundancy operation, in addition to the two units (operating and standby) a special redundancy kit is required. For 1:2 redundancy operation another redundancy kit is needed in addition to the three units. The kits include the waveguide switches, terminations, splitter, interconnecting cable assemblies and mounting frames.

All redundancy systems are delivered fully assembled, integrated, and tested.

Ku-Band Rack-mount SSPA/SSPB

Technical Specifications

Table A

Band*	RF Band (GHz)	L-Band Input for BUC (MHz)	LO for BUC (GHz)	Output Power (W)
KS	14.0 – 14.50	950 – 1450	13.05	8 - 500
KX	13.75 – 14.50	950 – 1700	12.80	8- 500*
KL	12.75 – 13.25	950 – 1450	11.80	8- 200

*Other frequency sub-bands are available. Please consult factory.

Table B

SSPA/SSPB (BUC) Line

Rated Power W	P _{sat} dBm	P _{1dB} dBm	Gain (dB) (minimum)		Availability in this series			Power consumption W (nominal)	Weight	Dimensions Outline
			SSPA	BUC	KS	KX	KL			
8W	+39	+38	+49	+59	√	√	√	170	37.5 lbs (17 kg)	3RU Outline #1
10W	+40	+39	+50	+60	√	√	√	180		
12W	+41	+40	+51	+61	√	√	√	200		
16W	+42	+41	+52	+62	√	√	√	250		
20W	+43	+42	+53	+63	√	√	√	300		
25W	+44	+43	+54	+64	√	√	√	350		
30W	+45	+44	+55	+65	√	√	√	550	66 lbs(30kg)	4RU Outline #2
40W	+46	+45	+56	+66	√	√	√	800		
50W	+47	+46	+57	+67	√	√	√	900		
60W	+48	+47	+58	+68	√	√	√	950		
80W	+49	+48	+59	+69	√	√	-	1000		
100W	+50	+49	+60	+70	√	√	-	1100	99 lbs(45kg)	5RU Outline #3
125W	+51	+50	+61	+71	√	√	√	1400		
150W	+52	+51	+62	+72	√	√	-	1700		
200W	+53	+52	+63	+73	√	√	√	2000	198 lbs(90kg)	8RU Outline #4 +2RU for power supply shelf
250W	+54	+53	+64	+74	√	√	-	2200		
300W	+55	+54	+65	+75	√	√	-	3500		
400W	+56	+55	+66	+76	√	√	-	4500		
500W	+57	+56	+67	+77	√	√	-	5500		

Ku-Band Rack-mount SSPA/SSPB

General Specifications

Operating Frequency	See table A		
L-Band input (BUC)	See table A		
Output Power	See table B		
Gain	See table B		
Gain adjustment range	20 dB in 0.1 dB steps		
Gain flatness over full band	SSPA ± 1 dB max	SSPB ± 1.5 dB max	
Gain slope over 40 MHz	SSPA ± 0.3 dB max	SSPB $\pm 0.0\%$ dB max	
Gain variation over temperature	± 1.0 dB max @ center frequency		
Input Impedance and VSWR	50 Ω	SSPA 1.3:1	SSPB (BUC) 1.4:1
Output VSWR	1.25:1		
Noise power density	-70 dBm/Hz in Transmit Band, -145 dBm/Hz in Receive Band (10.95 – 12.75 GHz)		
Spurious at P1dB	-65 dBc max		
Harmonics	-40 dBc @ P1dB, -50 dBc @ P1dB -3 dB max		
AM/PM conversion	2.5 ^o /dB at P1dB		
Third order intermod (two tones)	-25 dBc at 3 dB total back-off from rated P1dB (-23dBc max for 500W KX unit)		
Group delay	Linear	0.02 nsec/MHz max	
	Parabolic	0.003 nsec/MHz ² max	
	Ripple	1 nsec p-p max	
Residual AM Noise	0 – 10 kHz	-45 dBc	
	10 kHz – 500 kHz	-20 (1.25 + log F) dBc	F = Frequency in kHz
	500 kHz – 1 MHz	-80 dBc	
SSPB (BUC)			
Local Oscillator frequency	See table A		
Reference frequency	10 MHz	stability $\pm 1^{-8}$ over temp range aging $\pm 1^{-7}$ /year	
Phase Noise	-60 dBc/Hz at 10Hz	-85 dBc/Hz at 10 kHz	
	-65 dBc/Hz at 100Hz	-95 dBc/Hz at 100 kHz	
	-75 dBc/Hz at 1000Hz		
External Reference Frequency phase noise (max)	-115 dBc/Hz at 10Hz	-150 dBc/Hz at 10 kHz	
	-135 dBc/Hz at 100Hz	-160 dBc/Hz at 100 kHz	
	-148 dBc/Hz at 1000Hz		
Weight & Dimensions	See table B		
AC input voltage	Up to 125W output power	95 - 265 VAC, 47-63 Hz, Option 48V DC	
	150W output power and higher	220VAC 47 – 63 Hz	
Cooling system	Forced air with front intake		
Interfaces	Input (RF or L-Band)	N type female	
	Output Sample Port	N type female	
	RF output	WR75	
	AC line	IEC 320 inlet	
	RS232 serial port	D-sub 9S	
	RS485	D-sub 9S	
	Ethernet (option)	RJ45	
Environmental	Temperature	Operating 0°C to +50 °C Storage -55°C to +85 °C	
	Humidity	5% to 95% non-condensing	
	Altitude	10,000' AMSL, derated by 2 °C/1000' from AMSL	

Ku-Band Rack-mount SSPA/SSPB

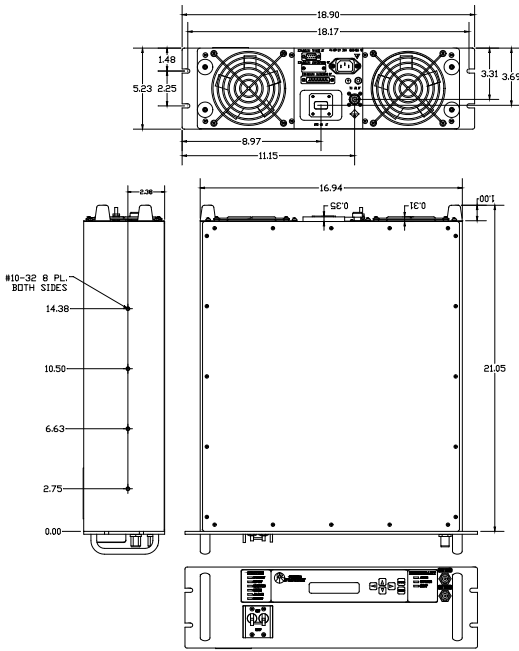

Outline 1

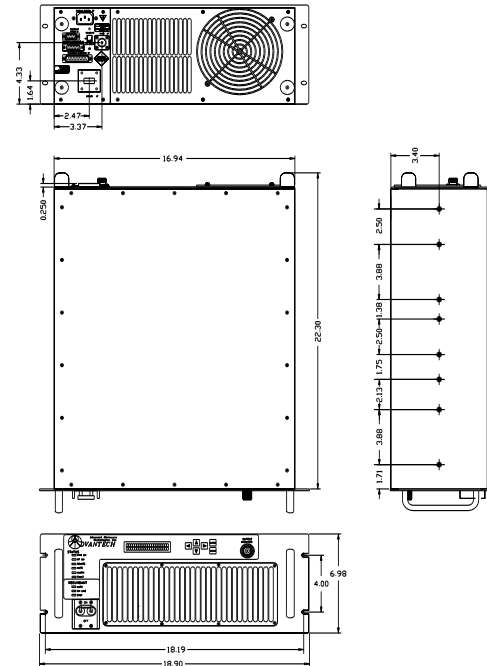

Outline 2

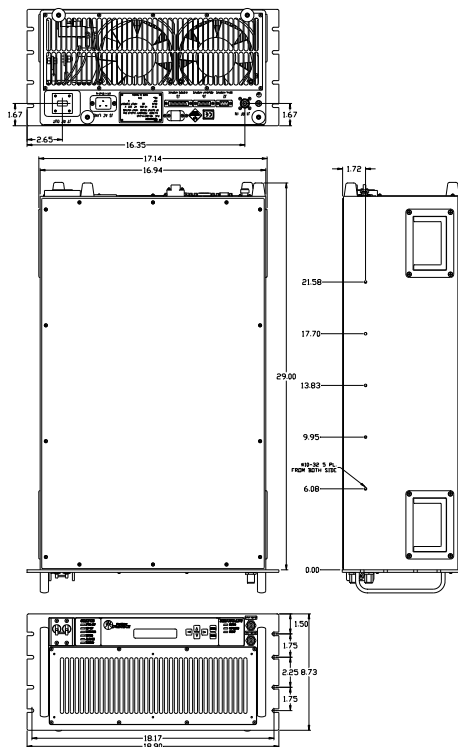

Outline 3

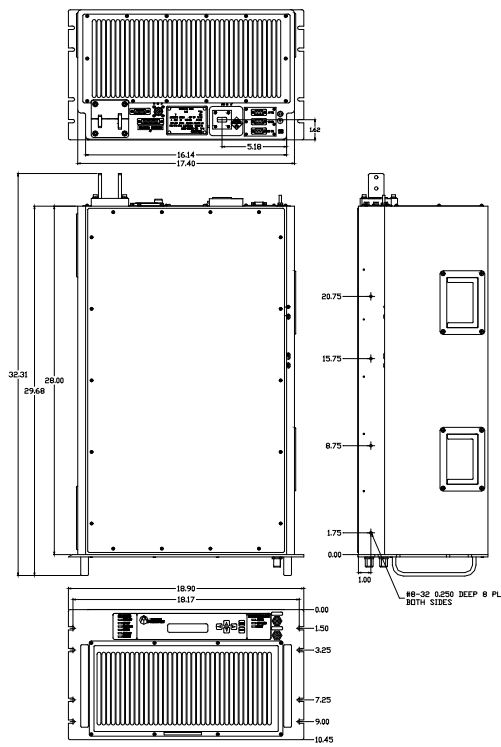

Outline 4

NORTH AMERICA
USA
 Tel: +1 703 659 9796
 Fax: +1 703 635 2212
 info.usa@advantechwireless.com

CANADA
 Tel: +1 514 420 0045
 Fax: +1 514 420 0073
 info.canada@advantechwireless.com

EUROPE
UNITED KINGDOM
 Tel: +44 1480 357 600
 Fax: +44 1480 357 601
 info.uk@advantechwireless.com

RUSSIA & CIS
 Tel: +7 495 971 59 18
 info.russia@advantechwireless.com

INDIA
 Tel: +91 33 2415 5922
 info.india@advantechwireless.com

SOUTH AMERICA
 Tel: +1 514 420 0045
 Fax: +1 514 420 0073
 info.latam@advantechwireless.com

BRAZIL
 Tel: +55 11 3054 5701
 Fax: +55 11 3054 5701
 info.brazil@advantechwireless.com

An ISO 9001 : 2008 Company



Ref.: PB-ARMA-Ku-8-500-13150