

FPM-5171G

17" SXGA Industrial Monitor with Resistive Touchscreen, Direct-VGA, and DVI Ports

NEW



Features

- 17" SXGA TFT LCD with resolution up to 1280 x 1024
- Direct VGA & DVI-D video input interface
- Lockable OSD keys with 2 user-defined contrast/brightness settings
- Flat-sealed front panel
- Robust design with anti-rust chassis and aluminum die-cast front panel
- Front accessible USB connector
- Combo RS-232 & USB interface for touchscreen function (optional)
- Supports industrial 10-30 V_{DC} power input
- Supports panel, wall, desktop, rack or VESA arm mounting
- Front panel is NEMA4/IP65 compliant

Introduction

FPM-5171G is a 17" color TFT LCD flat panel monitor specifically designed for industrial applications. With a viewing size as large as 17", it presents an ample display area as well as vivid and sharp images for your HMI. It features Direct-VGA & DVI-D signal transmission, which allows VGA control cards to be used in your system. The onscreen display allows users to adjust the images on the screen with two user-defined settings. The front access USB connector provides easy access the controller, and the industrial 10-30 Vdc wide range power support makes this product an excellent option for Factory and Machine Automation display solutions.

Specifications

General

- **Button Controls** OSD control pad on rear side with lockable function
- **Certification** BSMI, CCC, CE, FCC, UL
- **Dimension (W x H x D)** 481.9 x 355.9 x 58.5 mm (18.9" x 14" x 2.3")
- **Enclosure** Front panel: Aluminum and flat-sealed
Rear cover: Anti-rust coating
- **Mounting** Panel, wall, desktop, VESA arm, or 19" rackmount
- **Power Input** Phoenix Jack - 10 ~ 30 V_{DC} input
Optional external 57 W power adapter, with AC 100 V ~ 240 V input and DC +12 V @ 4.7A output
- **USB** Front USB access for extension
- **Video Port** VGA & DVI-D
- **Weight (Net)** 8 kg (17.63 lbs)

LCD Display

- **Display Type** SXGA TFT LCD
- **Display Size** 17"
- **Max. Resolution** 1280 x 1024
- **Max. Color** 16.7M
- **Viewing Angle (H/V°)** 160/160
- **Luminance (cd/m²)** 300
- **Backlight Life (hrs)** 50,000
- **Contrast Ratio** 800 : 1

Touchscreen (Optional)

- **Sensor** AMT
- **Driver** Penmount 6000
- **Type** 8-wire Resistive
- **Interface** RS-232 & USB
- **Lifespan** 10 million with a silicone rubber of R8 finger, writing rate is by 250g at 2 times/s
- **Light Transmission** > 80%
- **OS Support** Windows® 2000/XP/CE/Vista, Linux
- **Power Consumption** +5 V @ 100 mA
- **Touch Resolution** Linearity

Environment

- **Operation Temperature** 0 ~ 50° C (32 ~ 122° F)
- **Storage Temperature** -20 ~ 60° C (-4 ~ 140° F)
- **Humidity (Storage)** 10 ~ 90% non-condensing
- **Waterproof** Front panel is NEMA4/IP65 compliant
- **Vibration** 5 ~ 500 Hz, 1 Grms (Operating, Random)

Ordering Information

- **FPM-5171G-X0AE** 17" SXGA Ind. Monitor
- **FPM-5171G-R3AE** 17" SXGA Ind. Monitor w/Resistive TS (RS-232 & USB)

Dimensions

Unit: mm

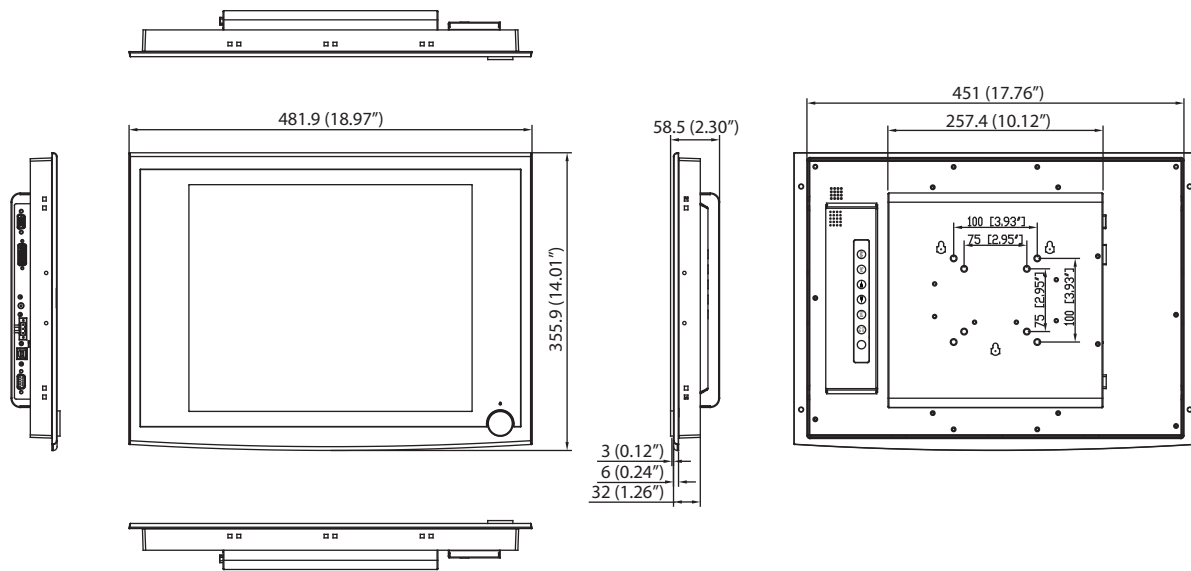

Panel Cut-out Dimensions: 454 x 338 mm

Accessories

- **FPM-5151G-SMKE** FPM-5151G/5171G Stand Kit
- **IPPC-6172A-RMKE** IPPC-6172A/FPM-5171G Rack Mount Kit
- **1702002600** Power Cable US Plug 1.8 M
- **1702002605** Power Cable EU Plug 1.8 M
- **1702031801** Power Cable UK Plug 1.8 M
- **1702031836** Power Cable China/Australia Plug 1.8 M
- **1757002742** Adapter AC 90-264V 57W SPU63-105

I/O View

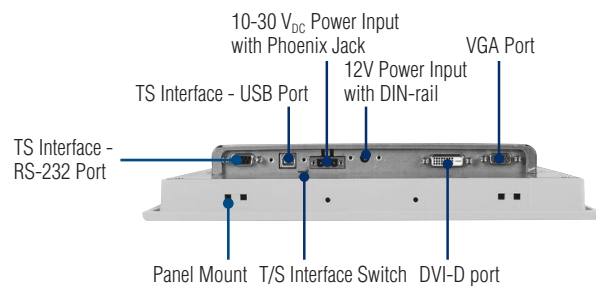

Front Accessible USB Port



Back View

