

N-TRON

THE INDUSTRIAL NETWORK COMPANY

700 SERIES Industrial Wireless Radio 702-W

The N-TRON® 702-W Industrial Wireless Radio provides outstanding performance and extreme reliability under the harshest industrial conditions. It is ideally suited for connecting wireless devices to a wired network or for connecting two wired networks where it is not possible, practical, or cost-effective to install cable.

The 702-W provides three antennas to facilitate Multiple In, Multiple Out (MIMO) technology for increased throughput. Power over Ethernet (PoE) capability enables the unit to receive power through a Cat5e cable from a PoE sourcing device, such as N-Tron's 105TX-POE Switch or 100-PoE4 Midspan Injector. This ability makes deployments of network nodes much easier as a single Cat5e cable is all that is needed to carry both power and data.

PRODUCT FEATURES

- One 10/100BaseTX RJ-45 port
- Three antennas for 3x3 MIMO operations
- Four user-definable LEDs for display of signal quality
- Radio enable, link/activity, and power LEDs
- Station roaming
- 802.3af PoE-powered device
- Extended environmental specifications
- Auto sensing 10/100BaseTX, duplex, and MDIX
- Rugged DIN-rail enclosure
- Redundant power inputs (20-49 VDC)
- Web browser management

Wireless Compliance

- IEEE 802.11a Compliant
- IEEE 802.11b Compliant
- IEEE 802.11g Compliant
- IEEE 802.11n Compliant

Security

- 802.11i with AES-CCM & TKIP Encryption
- 802.1x, 64/128 bit WEP

Data Rates

- Legacy 802.11a/b/g (1-54 Mbps)
- 802.11n (up to 300 Mbps)

Range Performance

- Indoor (antenna dependent) greater than 300m
- Outdoor (antenna dependent) greater than 60km

APPLICATIONS

The 702-W provides a reliable wireless connection that can be quickly and easily deployed at a fraction of the cost of hardwired installations. It is also ideal for network communications between mobile devices such as forklifts, heavy equipment, laptop computers, and other devices that are impractical or impossible to connect with copper or fiber cable.



Industrial Packaging and Specifications

The 702-W is specifically designed to operate in industrial environments. With its rugged enclosure and industrial specifications—including redundant power inputs and expanded tolerance to shock, vibration, electrical noise and temperature fluctuations—the 702-W easily meets and exceeds the operating parameters of connected equipment.

Multiple Wireless Modes

The 702-W provides a number of configuration options that allow customization to suit specific applications.

Station: In "station" configuration, the 702-W is used to connect a single device (MAC Address) to a wireless access point.

Station, WDS (Wireless Distribution System): In "station, WDS" mode, the 702-W can be connected to a remote wired switch, allowing multiple devices (MAC Address forwarding) to be connected to the wireless access point when WDS is activated.

Access Point: In "access point" mode, the 702-W serves as a wireless switch for attached wireless stations. Wireless access points are commonly used to create one wireless local area network (WLAN) that spans an area around the access point. Each access point typically supports up to 253 stations.

Access Point, WDS (Wireless Distribution System): In "access point, WDS" mode, the 702-W provides wireless connections to a number of access points, expanding the coverage of the wireless network. In this configuration, the main base access point is extended using a series of relay access points in WDS mode (Extended Service Set) and, in turn, can form a WLAN consisting of thousands of stations. All stations should be configured in "station WDS" mode. Correctly configured switches using WDS will create a single network, providing station mobility throughout the wireless network.

Multiple Network Modes

Bridge: The 702-W will operate in Layer 2 without network segmentation.

Router: The 702-W offers Layer 3 routing to allow network segmentation.

Scenario 1 – Basic Bridge

Access Point:

The "access point" mode allows the 702-W to serve as a wireless switch for the wireless stations attached to it. Wireless access points are commonly used to create one wireless local area network (WLAN) that spans an area around the access point. Each access point typically supports up to 253 stations.

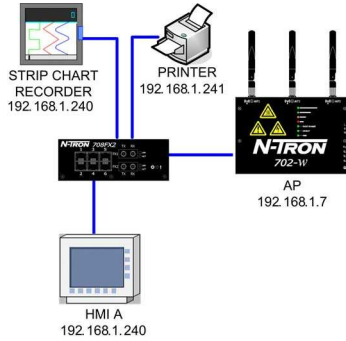

Station:

In "station" configuration, the 702-W is used to connect a single device (MAC address) to a wireless access point.

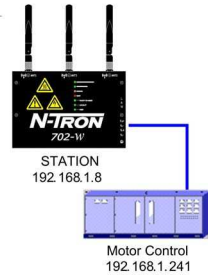

For added security, the 702-W supports WEP, WPA™, and WPA2™. WPA and WPA2, TKIP (Temporal Key Integrity Protocol) and CCMP (counter mode with Cipher Block Chaining Message Authentication Code Protocol) are available.

Scenario 2 – Control Network

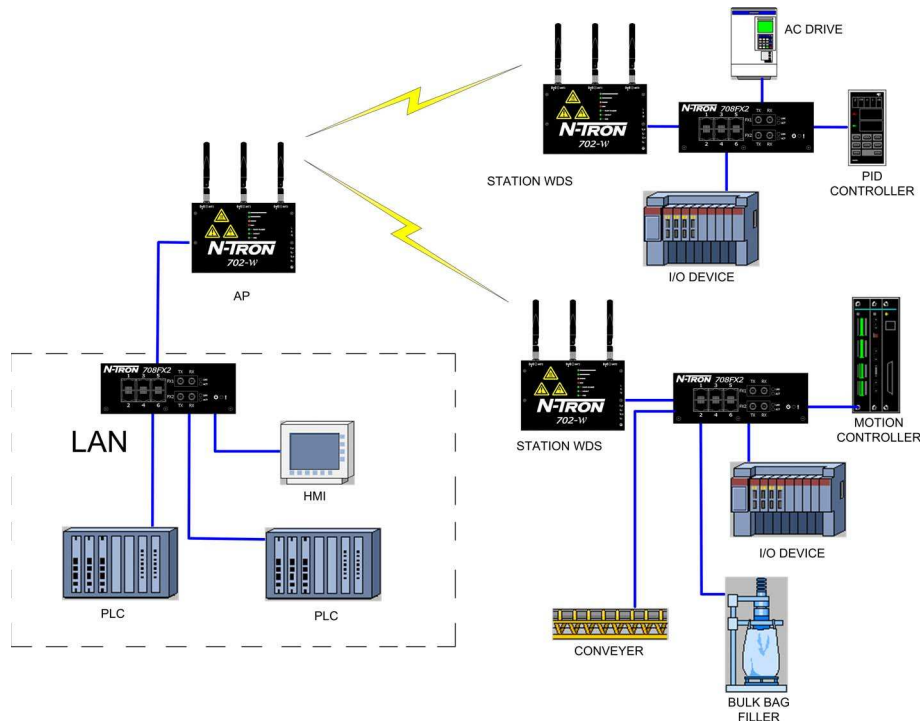

In station WDS mode, the 702-W can be connected to a remote wired Ethernet switch with multiple devices connected to the switch.

Scenario 3 – WDS Peering

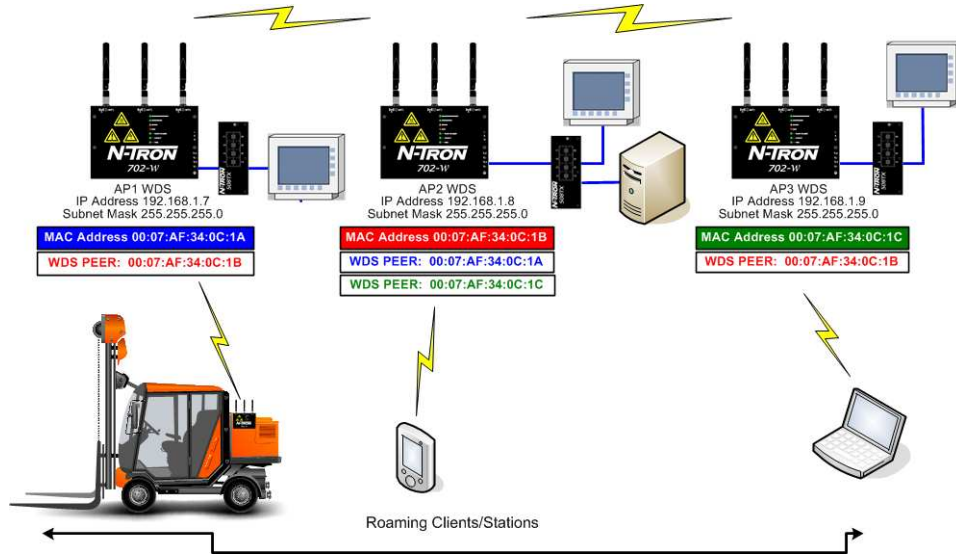

These 702-W wireless radios have been configured as peers. This topology allows forklifts, or other mobile wireless devices, to maintain communication as they move from the area covered by one 702-W into the area covered by the next 702-W.

Scenario 4 – Broadband Modem Wireless Router (W/ DHCP)

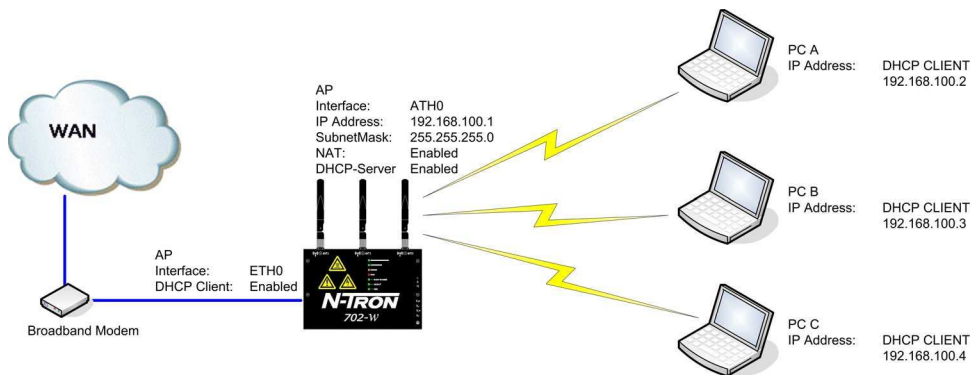

The 702-W configured as a powered router allows Layer 3 routing to setup network segmentation. It supports the Network Address Translation (Masquerading) feature which is widely used by access points. NAT will act as the firewall between LAN and WLAN networks. Additional firewall settings can be configured for Layer 3 packet filtering and access control in router mode. It can also act as a DHCP server, automating the assigning of IP addresses.

SPECIFICATIONS

Physical

Height: (w/o antennas): 5.2" (13.2 cm)
 Width: 7.4" (18.8 cm)
 Depth (includes DIN-Rail mount): 1.5" (3.9 cm)
 Weight (max): 1.9 lbs (0.9 kg)
 DIN-Rail Mount: 35 mm

Environmental

Operating Temperature: -40°C to 70°C
 Storage Temperature: -40°C to 85°C
 Operating Humidity: 5% to 95% (non condensing)
 Operating Altitude: 0 to 10,000 ft.
 N-TRON Power Supply: NTPS-24-1.3 (sold separately)

Electrical

Redundant Input Voltage: 20-49 VDC (regulated)
 Input Current (max): 200 mA max @ 24 VDC
 702-W Max Power: 4.8 watts max
 Input Ripple: Less than 100 mV

Reliability

MTBF: >1 million hours

Network Media

10BaseT: ≥Cat3 cable
 100BaseTX: ≥Cat5 cable
 802.11abgn: Air

Connectors

10/100BaseTX: One (1) RJ-45 copper port; PoE-powered device support
 802.11abgn: (3) RP-SMA connectors

Recommended Wiring Clearance (Antenna Dependent)

Front: 4" (10.2 cm)
 Side: 4" (10.2 cm)
 Top: 6" (15.3 cm)

Regulatory Approvals

- Safety: UL 508 and 1604
- Hazardous Location: Class I, Div 2, Groups A, B, C, D, T4A; ANSI/ISA-12.12.01-2007
- EMI: FCC/CE (CFR 47, Part 15, Subpart B - Class A); ANSI C63.4;
- EMC: R&TTE Directive 99/5/EC ; EN 301 489-3; IEC 61000-4-2 (ESD); IEC 61000-4-3 (RS)
- GOST-R Certified
- ROHS compliant

Radio Output Power:			Radio Receiver Sensitivity:		
Up to 250mW US					
802.11a	5GHz		802.11a	5GHz	
DataRate	Avg TX ±2dB		DataRate	Sens. ±3dB	
1-24Mbps	24 dBm		1-24Mbps	-96 dBm	
36Mbps	22 dBm		36Mbps	-95 dBm	
48Mbps	20 dBm		48Mbps	-94 dBm	
54Mbps	19 dBm		54Mbps	-91 dBm	
802.11b/g	2.4GHz		802.11b/g	2.4GHz	
DataRate	Avg TX ±2dB		DataRate	Sens. ±3dB	
1-24Mbps	24 dBm		1-24Mbps	-97 dBm	
36Mbps	22 dBm		36Mbps	-90 dBm	
48Mbps	20 dBm		48Mbps	-86 dBm	
54Mbps	19 dBm		54Mbps	-84 dBm	
802.11n	2.4GHz	5GHz	802.11n	2.4GHz	5GHz
DataRate	Avg TX ±2dB		DataRate	Sens. ±3dB	
MCS0	24dBm	24dBm	MCS0	-97dBm	-96dBm
MCS1	24dBm	24dBm	MCS1	-96dBm	-95dBm
MCS2	24dBm	24dBm	MCS2	-93dBm	-92dBm
MCS3	22dBm	22dBm	MCS3	-91dBm	-90dBm
MCS4	22dBm	22dBm	MCS4	-87dBm	-86dBm
MCS5	22dBm	22dBm	MCS5	-84dBm	-83dBm
MCS6	18dBm	18dBm	MCS6	-78dBm	-77dBm
MCS7	15dBm	15dBm	MCS7	-75dBm	-74dBm
MCS8	24dBm	24dBm	MCS8	-96dBm	-95dBm
MCS9	24dBm	24dBm	MCS9	-94dBm	-93dBm
MCS10	22dBm	22dBm	MCS10	-91dBm	-90dBm
MCS11	20dBm	20dBm	MCS11	-88dBm	-87dBm
MCS12	20dBm	20dBm	MCS12	-85dBm	-84dBm
MCS13	17dBm	17dBm	MCS13	-80dBm	-79dBm
MCS14	17dBm	17dBm	MCS14	-79dBm	-78dBm
MCS15	15dBm	15dBm	MCS15	-76dBm	-75dBm

Designed to comply with:
 IEEE 1613 for Electric Utility Substations
 NEMA TS1/ TS2 for Traffic Control



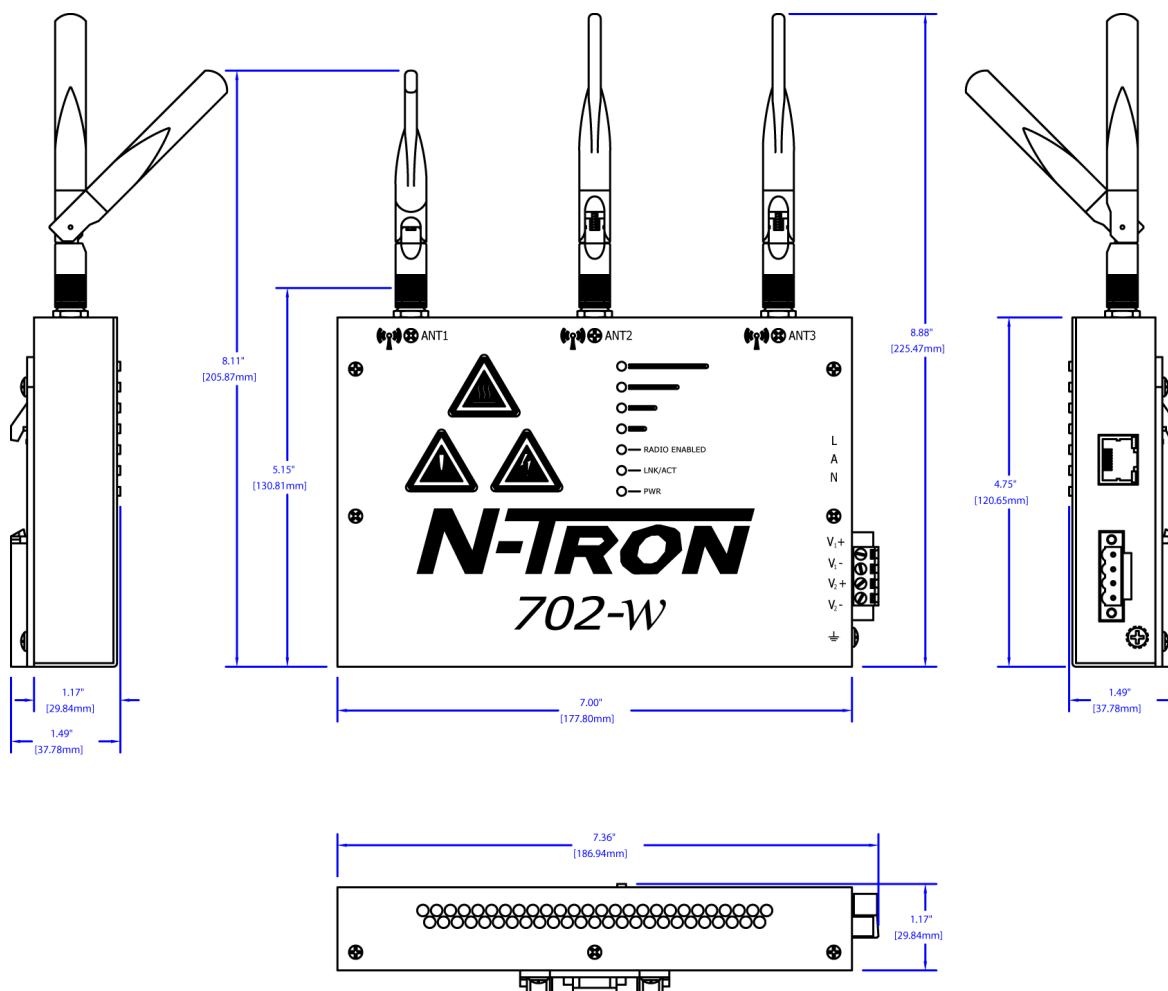

ORDERING INFORMATION

PART NUMBER	DESCRIPTION
702-W	1 Port (10/100BaseTX) Industrial Wireless Radio with three MIMO antennas, DIN-rail
702-W-PM	Panel mount kit for use with N-Tron's 702-W Wireless Radio
ANT-CAB-400-N-RPSMA-X	Low loss CA-400 coaxial cable with (1) RP-TNC connector and (1) N-male connector
ANT-CAB-195-RPSMA-RPSMA-X	702-W antenna bulkhead extension cable set; each cable includes (1) straight RP-SMA bulkhead jack and (1) 90° RP-SMA plug (package of 3)
ANT-MD24-12	2.4GHz 12dBi mini directional antenna and pole mount bracket included
ANT-PAD24-16	2.4GHz 16dBi panel directional antenna and pole mount bracket included
ANT-PAD58-19	5.8GHz, 19dBi panel directional antenna N-female connector and pole mount bracket included
ANT-PD58-32	5.8 GHz parabolic dish 32dBi directional antenna and pole mount bracket included
ANT-LA6-NFF	2-6GHz quarter wave lightning arrester (N-female to N-female, less than 0.2dB insertion loss, IP65, -40° to 85°C)
ANT-CAB-400-N-X	Low loss CA-400 coaxial cable with (2) N-female connector (for use with the ANT-LA6-NFF lightning arrester)
NTPS-24-1.3	DIN-rail power supply 24 VDC @ 1.3 amp



www.bb-elec.com orders@bb-elec.com support@bb-elec.com
International Office: 707 Dayton Road PO Box 1040 Ottawa, IL 61350 USA 815-433-5100 Fax 433-5104
European Office: Westlink Commercial Park Oranmore Co. Galway Ireland +353 91 792444 Fax +353 91 792445

QUALITY MANAGEMENT SYSTEM
CERTIFIED BY DNV
== ISO 9001:2008 ==