

RS-232 to RS-422/485

Model 422CINA

Description:

The 422CINA converts unbalanced, full-duplex RS-232 signals to balanced, full or half-duplex RS-422 or RS-485 signals. The following signals are supported: TD on pin 2, RD on pin 3, RTS on pin 4, and CTS on pin 5.

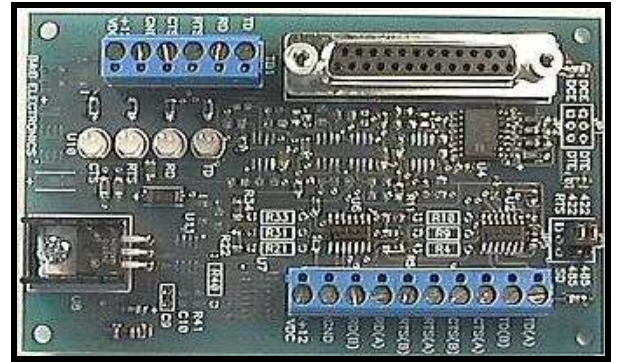

Specifications:

Signals Supported: TD, RD, RTS, & CTS
Dimensions: Approximately 2.75" x 4.60" x 0.68"
Data Rate: Up to 115.2K baud
Connectors:
RS-232: DB25S (female) and Terminal Blocks
RS-422/485: Terminal Blocks
Power Requirements:
From +12VDC to +18VDC at 160mA maximum.

Configuration:

In RS-485 mode, the driver enable is controlled with the RTS line from the RS-232 port. We refer to this as RTS control. With jumper JP3 in the 485 position the driver is enabled when the RTS handshaking line is asserted by your software. You must then disassert RTS in order to disable the RS-485 driver. With jumper JP4 in the 485 position, the receiver will be disabled while the driver is enabled. Jumper JP4 can be put in the 422 position for constant enable of the receiver.

In RS-422 mode, jumpers JP3 & JP4 should be in the 422 position. In 422 mode the driver and receiver will always be enabled for full-duplex communications. There are 4 two-color LEDs for monitoring the supported signals (red = neg. voltage, green = pos. voltage).

The board layout has an option for termination resistors (approx. 120 ohm): R9 for the 422/485 RD lines, and R31 for the 422 CTS lines.

The RS-422 Standard recommends 24AWG copper conductor, twisted-pair telephone cable with a shunt capacitance of 16pf per foot up to 4000 feet.

Power can be connected to TB1 at +12VDC and GND, or TB2 at +12VDC and IGND.

Connect the 422/485 signals to TB2 as follows:

2-WIRE MODE

| 422CINA: | 485 Device: |
|---------------------------------------|-------------|
| TD(A) & RD(A) ----- | (A) or (-) |
| TD(B) & RD(B) ----- | (B) or (+) |
| <i>If used:</i> RTS(A) & CTS(A) ----- | (A) or (-) |
| RTS(B) & CTS(B) ----- | (B) or (+) |

4-WIRE MODE

| 422CINA: | 422/485 Device: |
|------------------------------|----------------------------|
| TD(A) ----- | Receive Data (A) or (-) |
| TD(B) ----- | Receive Data (B) or (+) |
| RD(A) ----- | Transmit Data (A) or (-) |
| RD(B) ----- | Transmit Data (B) or (+) |
| <i>If used:</i> RTS(A) ----- | Clear To Send (A) or (-) |
| RTS(B) ----- | Clear To Send (B) or (+) |
| CTS(A) ----- | Request To Send (A) or (-) |
| CTS(B) ----- | Request To Send (B) or (+) |

MODEL 422CINA

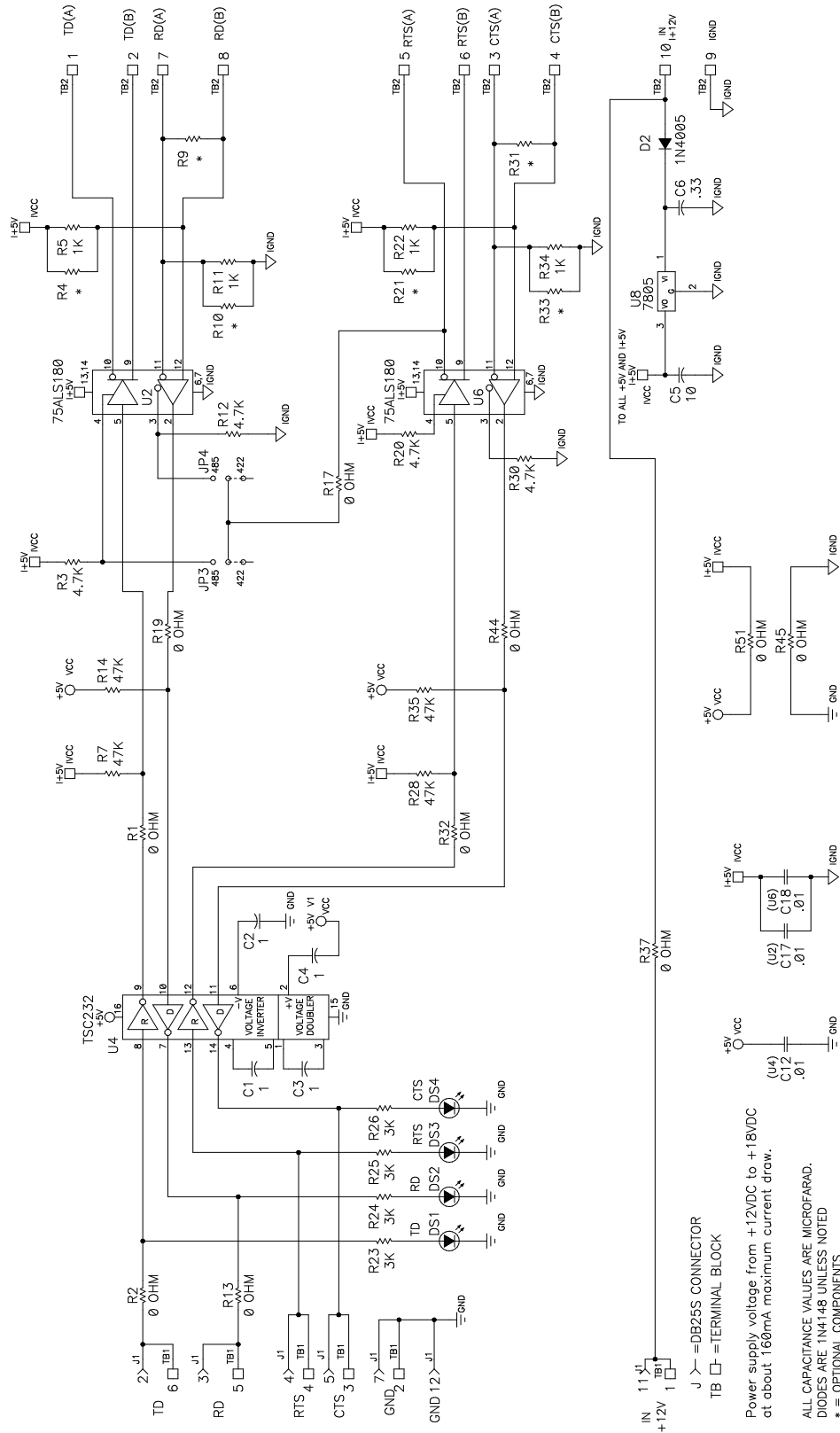

J = DB25S CONNECTOR
 TB = TERMINAL BLOCK

Power supply voltage from +12VDC to +18VDC at about 160mA maximum current draw.

ALL CAPACITANCE VALUES ARE MICROFARAD. DIODES ARE 1N4148 UNLESS NOTED * = OPTIONAL COMPONENTS