

Broadcast Serial Data From a Fiber Optic Port to 4 RS-232 Ports

CE
Model FDS4FE

Description:

The FDS4FE is designed to provide communication using fiber optic technology. It broadcasts data to four RS-232 devices from one set of fiber optic cables. The FDS4FE is expandable, allowing two or more FDS4FE devices to be cascaded together. Each additional FDS4FE adds four more RS-232 ports communicating with one Master port. The converter is designed for a multi-drop Master/Slave configuration, allowing one "Master" port to communicate to the "Slave" devices at distances of up to 2.5 miles.

RS-232 data rates up to 115.2kbps are supported. The FDS4FE supports both the Transmit and Receive data lines. All serial connections are provided on the DB-9 male connectors, the multimode fiber is connected via ST connectors, and RJ-45 connectors are used for the expansion port.

The unit must be powered with 10-30 VDC (370 mA @10V). Power can be supplied through the power jack, or the terminal block located inside the enclosure.



RS-232 Connections:

The DB-9 male serial connectors are used for connecting to RS-232 devices. The RS-232 signals are pinned as a DTE device (input on pin 2 and output on pin 3). A straight through cable can be used from your DB-9 port on any DCE device. A standard 9 to 25-pin adapter can be used in cases where the serial port on the DCE device is a DB-25. A null modem cable or adapter that swaps pins 2 and 3 is needed for connecting to PCs, terminals or other DTE devices. See Figure 2 for connection diagrams to 9 pin and 25 pin DTE and DCE devices.

Figure 1: Typical Setup

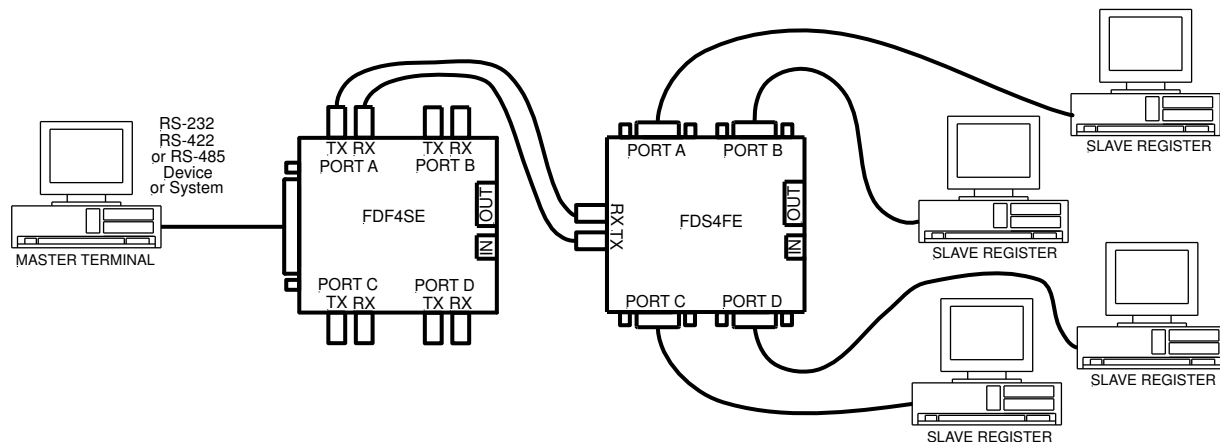
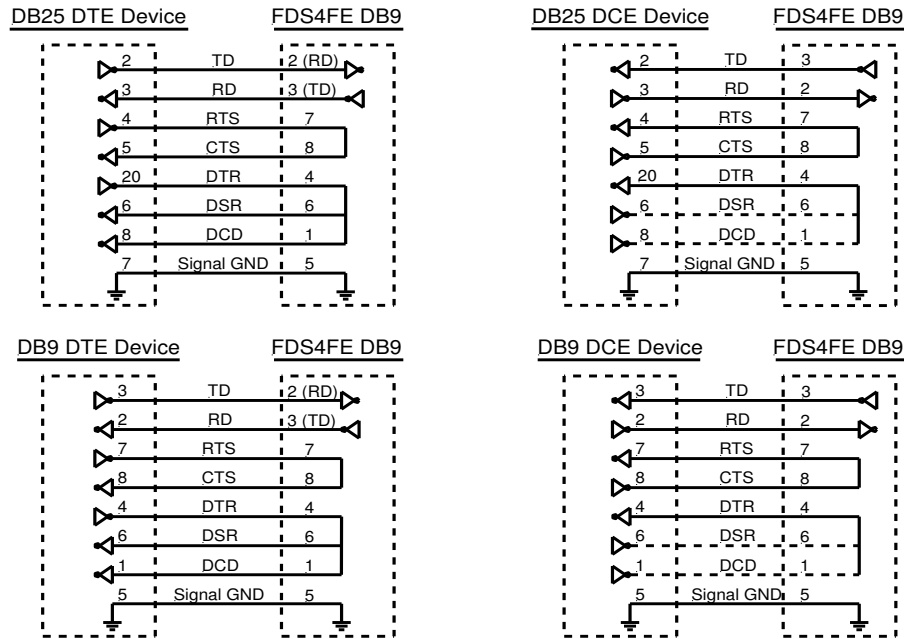

Figure 2: RS-232 Connection Diagrams



Expansion Port Connections:

The expansion port utilizes RS-422 data signals with RJ-45 connectors. To use the expansion feature simply connect a cable from the OUT of the upstream device to the IN of the next device.

If termination is needed, a spot on the PCB labeled, R36 for the OUT connection and R37 for the IN connection, allows you to solder in a termination resistor across the RD(A) and RD(B) lines. The off-state bias resistor values can be changed by removing R34 and R40, for the OUT side of the expansion port, and replacing them with through-hole components in the spots labeled R35 and R41. For the IN side of the expansion port, remove R32 and R38, and replace them with through-hole components in the spots labeled R33 and R39. Before making modifications to the FDS4SE, be sure to consult B&B Electronics' free RS-422/485 Application Note or other sources of information to see if termination is necessary. The RS-422/485 Application Note is available from our Web site, or call B&B to have a copy mailed to you at no charge.

Fiber Optic Connections:

The FDS4FE uses a separate LED emitter and photo-detector operating at an 820 nm wavelength. Connections to the emitter and detector are done with ST type connectors. Almost any multimode glass fiber size can be used including 50/125 μm, 62.5/125 μm, 100/140 μm, and 200 μm. Two fibers are required between the two devices, one for each direction of data. See Figure 1 for a typical multi-drop configuration using an FDF4SE and an FDS4FE. Model FDF4SE was designed in conjunction with the FDS4FE to take RS-232/422/485 data, send it across fiber optic lines, and broadcast it out to 4 serial ports.

The most important consideration in planning the fiber optic link is the "power budget" of the fiber device. This value represents the amount of loss in dB that can be present in the link between the two fiber devices before the units fail to perform properly. This value includes line attenuation as well as connector loss. For the FDS4FE, the typical connector-to-connector power budget is 12.1 dB. Because 62.5/125 μm cable typically has a line attenuation of 3 dB per Km at 820 nm, the 12.1 dB power budget translates into 2.5 miles. This assumes no extra connectors or splices in the link. Each extra connection would typically add 0.5 dB of loss, reducing the possible distance by 166 m (547 ft.). The actual loss should be measured before assuming distances.

Specifications:

Transmission Line: Dual multimode optical cable
 Interface: RS-232
 Data Rates: Up to 115.2kbps
 Typical Range: Up to 2.5 miles on multimode glass fiber
 Coupled Power Budget: 12.1 dB
 Optic Wavelength: 820 nm
 Connectors: DB-9 male for serial connection ST for fiber RJ-45 for the expansion port
 Power Requirements: 10-30 VDC (370 mA @10V)
 Dimensions: 5.6 x 3.8 x 1.3in (14.1 x 9.7 x 3.2cm)

DECLARATION OF CONFORMITY	
Manufacturer's Name:	B&B Electronics Manufacturing Company
Manufacturer's Address:	P.O. Box 1040 707 Dayton Road Ottawa, IL 61350 USA
Model Numbers:	FDS4FE
Description:	Fiber Optic to Serial Converter Hub
Type:	Light industrial ITE equipment
Application of Council Directive:	89/336/EEC
Standards:	EN 50082-1:1998 EN 61000 -4(-2, -3, -4, -6) ENV 50204

Robert M. Paratore
Robert M. Paratore, Director of Engineering

Figure 3: FDS4FE Circuit Diagram

