



Models 485DRC and 485LDRC Industrial DIN Rail Mounted Optically Isolated RS-232 to RS-422/485 Converters With Surge Suppression

Introduction

The DIN Rail mountable Models 485DRC and 485LDRC optically isolate and convert unbalanced, full or half-duplex RS-232 signals to optically isolated, balanced, full or half-duplex RS-422 or RS-485 signals at baud rates up to 115.2 kbps. These units also surge suppress the RS-422/485 lines. They feature Send Data Control circuitry so no software control of handshake lines is required in RS-485 mode.

LEDs

The 485LDRC includes all the above features plus 3 LED's: one indicating RS-485 Transmit Data, one for RS-485 Receive Data, and one for power.

Description

The 485DRC/485LDRC has screw down terminal blocks on the RS-232 side and the RS-422/RS-485 side. Transmit (TD), Receive (RD) and Ground are supported on the RS-232 side. The unit is powered by a supply voltage of 10 to 30VDC on the RS-232 side, useful where 24VDC is commonly found. Transmit Data A (-), Transmit Data B (+), Receive Data A (-), Receive Data B (+), and Ground are supported on the RS-422/RS-485 side. Communication features on the 485DRC/485LDRC are dipswitch selectable on the unit.

RS-485 Mode with Send Data Control

Send Data Control recognizes the first bit of data from the RS-232 side, enables the transmitter and disables the receiver. After the last bit of data is sent from the RS-232 side, the timeout waits one character length, then disables the transmitter and enables the receiver. The timeout can be selected with dipswitches or by changing the value of R11 (see Table 2). If the system requires the line to be "turned around" faster, i.e. the slave device starts responding before the transmitter of the 485DRC/485LDRC is disabled, R11 can be changed to meet the specific baud rate. Termination resistance can be selected with Switch 5 for high baud rates and long cable distances. See B&B Electronics' RS-422/485 Application Note available on the website or by mail. Factory setting: 9600 baud.

Table 1. Typical Communication Setups

	Switch 1 TX Enable	Switch 2 RX Enable	Switch 3 2/4 Wire	Switch 4 2/4 Wire
RS-485 2-Wire Mode (half-duplex)	ON	ON	ON	ON
RS-485 4-Wire Mode (full-duplex)	ON	OFF	OFF	OFF
RS-422 Mode (full-duplex)	OFF	OFF	OFF	OFF

Table 2. Baud Rate Selection

	Switch 6	Switch 7	Switch 8	R11	Time (ms)
1200	OFF	OFF	OFF	820kΩ	8.33
2400	OFF	OFF	ON	Not Used	4.16
4800	OFF	ON	OFF	Not Used	2.08
9600	ON	OFF	OFF	Not Used	1.04
19200	ON	ON	ON	Not Used	.580
38400	OFF	OFF	OFF	27kΩ	.260
57600	OFF	OFF	OFF	16kΩ	.176
115200	OFF	OFF	OFF	8.2kΩ	.0868

TYPICAL RS-422/485 4 WIRE

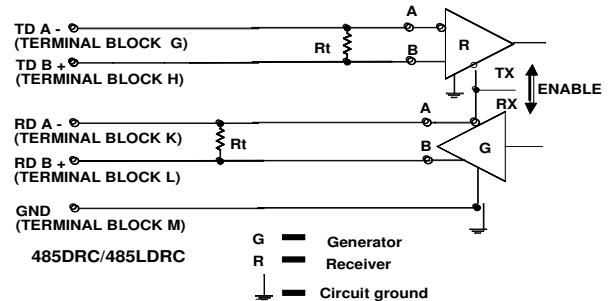

TYPICAL TWO-WIRE RS-485 SETUP

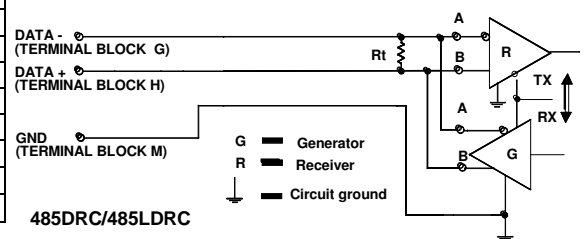

In a two-wire setup, switches 3 & 4 should be "ON", making terminal block (G) the Data (-) line and terminal block (H) the Data (+) line.

Terminal Block Configuration

RS-232

- (D) TD (input)
- (A) RD (output)
- (B) SIG. GND
- (F) +10 to 30VDC
- (C) PWR. GND

RS-422/485

- TDA (G) Tx inverted or (-) (output)
- RDA (K) Rx inverted or (-) (input)
- TDB (H) Tx non-inverted or (+) (output)
- RDB (L) Rx non-inverted or (+) (input)
- ISO. GND (M) Isolated RS-422/485 Signal Ground/Common

Switch Settings (UP = ON)

- 1 - Tx Enable (On for 485 mode. Off for 422 mode.)
- 2 - Rx Enable (On for 2-wire 485 mode. Off for 4-wire 485 and 422 mode.)
- 3 - 2/4 Wire (On for 2-wire/half duplex. Off for 4-wire full duplex.)
- 4 - 2/4 Wire (On for 2-wire. Off for 4-wire.)
- 5 - Termination Resistors (On for termination. Off for no termination.)
- 6 - 9600 Baud (On for 9600, Off for others. See Table 2 for additional baud rates.)
- 7 - 4800 Baud (On for 4800, Off for others. See Table 2 for additional baud rates.)
- 8 - 2400 Baud (On for 2400, Off for others. See Table 2 for additional baud rates.)

485DRC and 485LDRC
 Side Terminals & Wire
 Clamp Screws
 1.0 X 3.1 X 4.2 in.
 25.4 X 78.7 X 106.7 mm

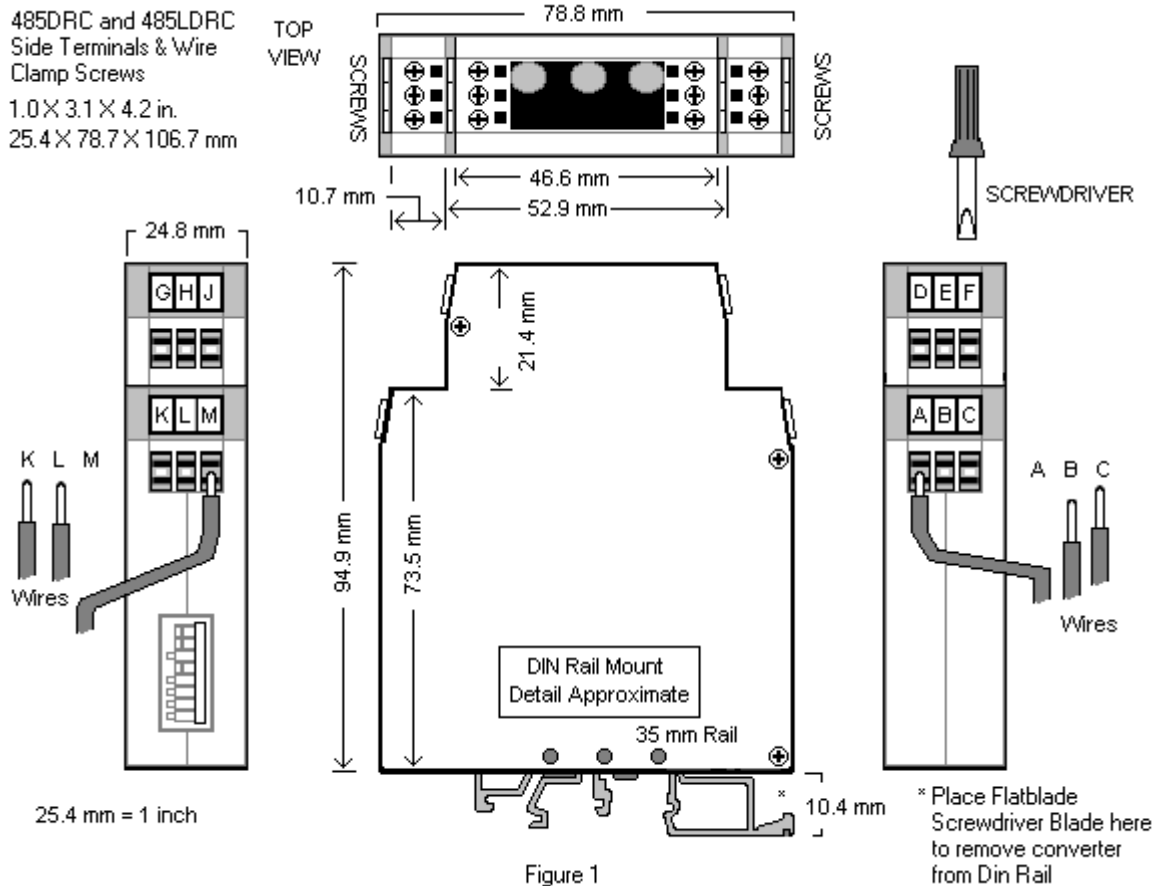

Removing Converter from DIN Rail

A flat blade screwdriver will be needed when removing the 485DRC / 485LDRC from a 35mm DIN rail.

1. Place a flat blade screwdriver blade in disengage clip on the converter enclosure (See Figure 1).
2. Gently pry on screwdriver handle.
3. Rock enclosure toward you to release it from the DIN rail.

Specifications

Dimensions: 4.2 x 3.1 x 1.0 in (106.7 x 78.7 x 25.4mm)
 Temperature Range: -40 to +80°C (-40 to +176°F)
 Humidity Range: 0 to 95% non-condensing
 Supply Voltage: +10 to 30VDC @ 100mA
 +9 to 30 VAC @ 100 mA
 Data Rates: 1200 to 115.2 kbps
 2400 to 19200 kbps switch selectable
 Connectors: Screw down terminal blocks for RS-232 and RS-422/485 sides
 LED's: (485LDRC only) – Transmit Data, Receive Data and Power
 Isolation: 2000VAC Optical Isolation of Data Signals and Ground
 Surge Suppression: 7.5V, bi-directional avalanche breakdown device
 500W peak power dissipation
 Clamping time < 1 picosecond (theoretical)

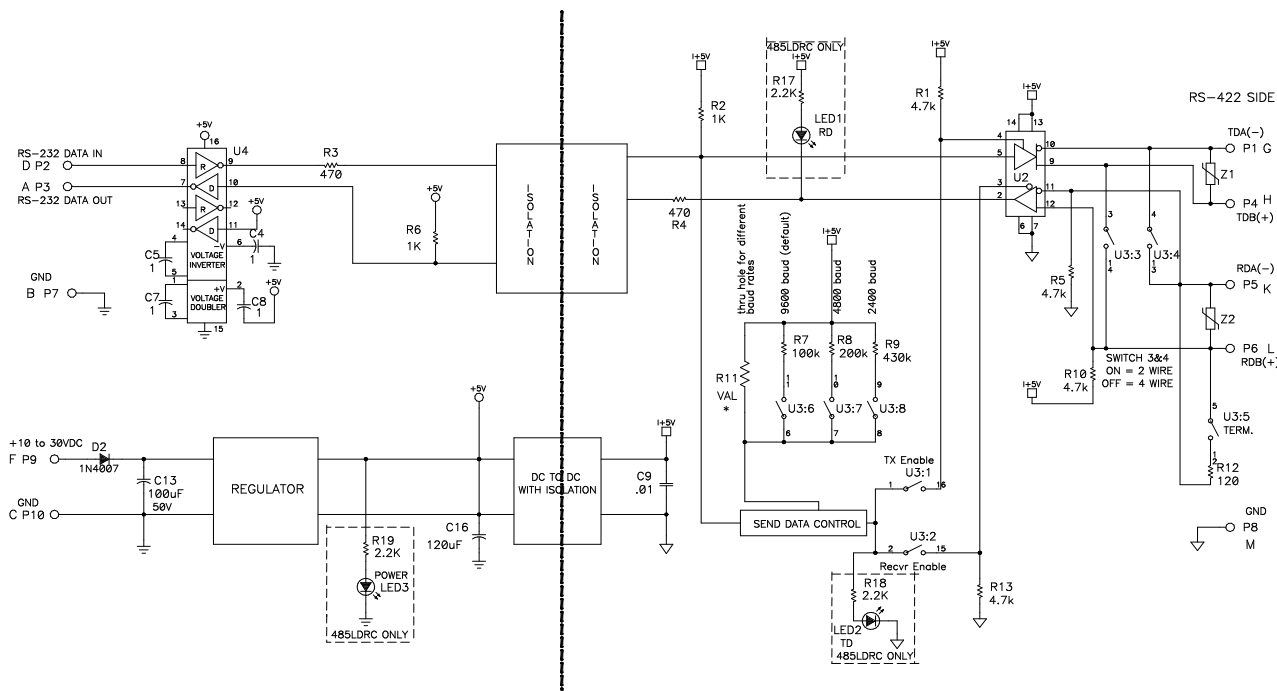

DECLARATION OF CONFORMITY

Manufacturer's Name: B&B Electronics Manufacturing Company
 Manufacturer's Address: P.O. Box 1040
 707 Dayton Road
 Ottawa, IL 61350 USA
 Model Number: 485DRC and 485LDRC
 Description: RS-485 Converter Optical Isolated DIN Converters
 Type: Light industrial ITE equipment
 Application of Council Directive: 89/336/EEC
 Standards: EN 55022
 EN 61000-6-1
 EN 61000 (-4-2, -4-3, -4-4, -4-5, -4-6, -4-8, -4-11)

Robert M. Paratore

Robert M. Paratore, Director of Engineering

