

# 485DRCI

## Industrial RS-232 to RS-422/485 Converter

- ✓ Data Rates up to 115.2 Kbps
- ✓ 10 – 48 VDC Input Power Range
- ✓ Wide Operating Temperature
- ✓ 3-Way 2000V Optical Isolation
- ✓ Modbus ASCII/RTU Compatible
- ✓ UL Class 1 Division 2



The Ilinx™485DRCI is our premium Industrial RS-232 to RS-422/485 Converter. Designed for rugged industrial use, it is UL approved and certified for operation in Class 1 Division 2 environments.

This DIN rail mountable converter optically isolates and converts unbalanced, full or half-duplex RS-232 signals to balanced RS-422/485 signals at baud rates up to 115.2 Kbps. In addition to optical isolation, the unit has surge suppression on the RS-422/485 lines. Featuring Automatic Send Data Control circuitry, it does not require special software control of handshake signals in RS-485 mode. The removable terminal blocks for power and RS-422/485 signals make wiring easy. It is powered by a supply voltage of 10 to 48 VDC which is isolated from all data and signal ground lines. Configuration is made easy with a 12 position DIP switch on the bottom of the converter.

Remember, when it comes to reliable communications in harsh industrial environments, B&B Electronics' Ilinx™ brand converters and isolators are your number one choice.

### Specifications

#### Serial Technology

RS-232	TD, RD, GND
RS-485 2-Wire	Data A(-), Data B (+), GND
RS-422/485 4-Wire	TDA(-), TDB(+), RDA (-), RDB(+), GND
RS-232 CON.	DB9 Female (DCE)
RS-422/485 CON.	Removable Terminal Block, 28 to 14 AWG
Data Rate	1.2 to 115.2 Kbps
Isolation	2000 V, 3-Way (Input, Output, Power)
Surge Protection	600 W Peak Power Dissipation Clamping time < 1 pico-second
Industrial Bus	MODBUS ASCII / RTU

#### Power

Source	External
Input Voltage	10 to 48 VDC
Power Consumption	960 mW
Connector	Removable Terminal Block, 28 to 14 AWG

#### Mechanical

LED Indicators	Transmit, Receive, and Power
Dimensions	4.5 x 1.3 x 4.9 in (11.4 x 3.3 x 12.4 cm)
Enclosure	35mm DIN Mount, Plastic, IP30
Weight	0.45 lbs (204.12 g)

#### Environmental

Op TEMP	- 40 to 176 °F (-40 to 80 °C)
Storage TEMP	- 40 to 185 °F (-40 to 85 °C)
Op Humidity	0 to 95% Non-condensing

#### Regulatory

Approvals	FCC, CE, cUL, Class 1 Division 2
UL File Number	E222870 (C1 D2 E245458)
MTBF	254617
MTBF Calc. Method	Parts Count Reliability Prediction

#### Class 1 DIV 2 Wiring

Type	Solid Copper Only
Size	28 to 14 AWG
Temperature	105°C (221 °F) Minimum
Terminal Torque	0.5 Nm (Newton-meters)

### Ordering Information

485DRCI	Ind. RS-232 to RS-422/485 Converter
<b>Accessories</b>	
MDR-20-24	Ind. 24VDC 1A Slimline Power Supply



## Package Contents

- 485DRCI Industrial RS-232 to RS-422/485 Converter
  - Datasheet
  - Power Terminal Block (installed)
  - RS-422/485 Terminal Block (installed)
- If any item is missing or damaged, contact B&B Electronics for a replacement

## Special Precautions for Class 1 Div 2 Environment

### Special Instructions for Installation and Operation in a Class 1 DIV 2 Environment.

1. Power, input / output (I/O) wiring must be in accordance with Class 1 Division 2 wiring methods [Article 501.10(B) of the National Electrical Code, NFPA70] and in accordance with the local authority having jurisdiction.
2. **WARNING – EXPLOSION HAZARD:** SUBSTITUTION OF ANY COMPONENTS MAY IMPAIR SUITABILITY FOR CLASS 1, DIVISION 2.
3. **WARNING – EXPLOSION HAZARD:** WHEN IN HAZARDOUS LOCATIONS, TURN OFF POWER BEFORE REPLACING OR WIRING MODULES
4. **WARNING – EXPLOSION HAZARD:** DO NOT DISCONNECT EQUIPMENT UNLESS POWER HAS BEEN SWITCHED OFF OR THE AREA IS KNOWN TO BE NON-HAZARDOUS.
5. **WARNING – THIS APPARATUS IS SUITABLE FOR USE IN CLASS 1, DIVISION 2, GROUPS A, B, C, AND D, OR UNCLASSIFIED LOCATIONS.**

## Front Panel

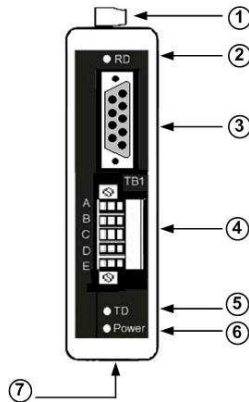

1	Power TB	2 Position, Removable
2	RD LED	Red, Flashes when RS-422/485 Data Received
3	DB9 F	RS-232 (Wired DCE)
4	422/485 TB	5 Position, Removable
5	TD LED	Red Flashes when RS-422/485 Data Transmitted
6	Power LED	Red, ON When Power Applied
7	Dip Switch	12 Position

## DIP Switch (SW1)

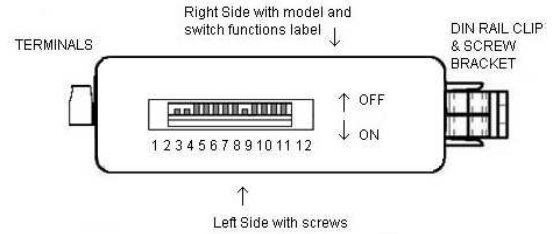

Pos	ON	OFF
1	RS-485	RS-422
2	Half Duplex	Full Duplex
3	2-Wire	4-Wire
4	2-Wire	4-Wire
5	Termination In	Termination Out
6	TX Bias In	TX Bias Out
7	RXBias In	RX Bias Out
8	2400 baud	
9	4800 baud	
10	9600 baud	
11	19.2 k baud	
12	38.4 k baud	

## RS-232 DB9F (DCE)

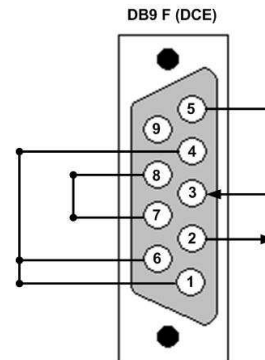

Pin	Signal	Direction
1	Receive Line Signal Detector (DCD)	---
2	Receive Data (RD)	OUTPUT
3	Transmit Data (TD)	INPUT
4	DTE Ready (DTR)	---
5	Signal Ground (SG)	---
6	DCE Ready (DSR)	---
7	Request to Send (RTS)	---
8	Clear to Send (CTS)	---
9	Ring Indicator (RI)	---

1. DB9 Female Connector is DCE.
2. Pin 2 (RD) is the Converter's RS-232 Data Output.
3. Pin 3 (TD) is the Converter's RS-232 Data Input.
4. Pins 1, 4, and 6 (DCD, DTR, and DSR) are jumpered together internally.
5. Pins 7 and 8 (RTS and CTS) are jumpered together internally.

## RS-422/485 Terminal Block

Terminal	RS-485 2-Wire	RS-422/485 4-Wire
A	GND	GND
B	Data B(+)	RDB(+)
C	Data A(-)	RDA(-)
D	---	TDB(+)
E	---	TDA(-)

## DIN Rail Mounting

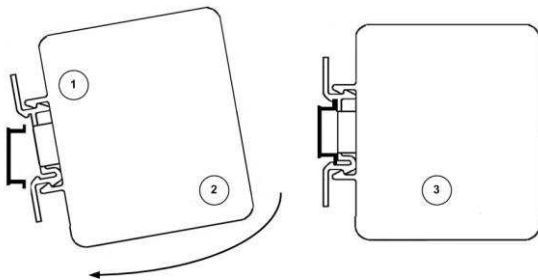

1. Angle the top portion of the DIN mount over the top of DIN Rail.
2. Move the converter so that it is parallel with the DIN Rail.
3. Snap the bottom of the DIN mount in place.

## RS-422/485 Baud / Timeout

Baud (Kbps)	Switch Selectable					Timeout (ms)
	SW1 8	SW1 9	SW1 10	SW1 11	SW1 12	
2.4	ON	OFF	OFF	OFF	OFF	4.16
4.8	OFF	ON	OFF	OFF	OFF	2.08
9.6	OFF	OFF	ON	OFF	OFF	1.04
19.2	OFF	OFF	OFF	ON	OFF	0.580
38.4	OFF	OFF	OFF	OFF	ON	0.260

Baud (Kbps)	Resistor Selectable		Timeout (ms)
	SW1-8 through 12	R-11 Value	
1.2	OFF	820 KΩ	8.33
57.6	OFF	16 KΩ	0.176
115.2	OFF	8.2 KΩ	0.087

1. Pre-defined baud rates are set using SW1 positions 8 through 12.
2. Resistor Selectable baud rates are set by inserting a through-hole resistor (R-11) on the circuit board.
3. **WARNING – EXPLOSION HAZARD:** SUBSTITUTION OF ANY COMPONENTS MAY IMPAIR SUITABILITY FOR CLASS 1, DIVISION 2.

## RS-485 2-Wire (Half Duplex)

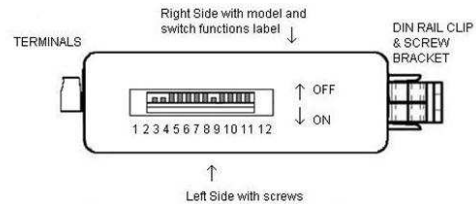
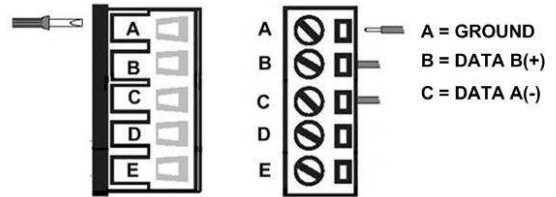

DIP Switch SW-1

1	2	3	4	5	6	7
ON	ON	ON	ON	X	Y	Z

POSITIONS 8 THROUGH 12 ARE USED TO SET THE BAUD RATE.

1. Loosen the screws to open the TB lead clamps for the A, B, and C terminals.
2. Insert the RS-485 2-Wire signal leads. The terminal board accepts 28 to 14 AWG wire.
3. Tighten the screws to close the TB lead clamps. Ensure the clamps hold the leads securely. However, do not over tighten. For Class 1 DIV 2 installations, ensure the wiring is in accordance with the special precautions and the specification table.
4. Configure the DIP Switch on the bottom of the converter for RS-485 2-Wire operation (see above).
  - X. ON = Termination IN  
OFF = Termination OUT
  - Y. ON = TX Bias IN  
OFF = TX Bias OUT
  - Z. ON = RX Bias IN  
OFF = RX Bias OUT

### Installation Notes:

- In 2-Wire mode, Terminal B is tied to Terminal D and Terminal C is tied to Terminal E with DIP Switch SW1-3 and SW1-4.
- If Termination is required, a 120Ω resistor can be placed across the D and E terminals by setting SW1-5 to ON.
- This converter has 1.2 KΩ pull-up/down bias resistors built in. To use this bias, set SW1-6 and SW1-7 to ON.
- B&B Electronics' RS-485 Application Note contains more information about termination and biasing. This reference is available on our web site.

## RS-485 4-Wire (Full Duplex)

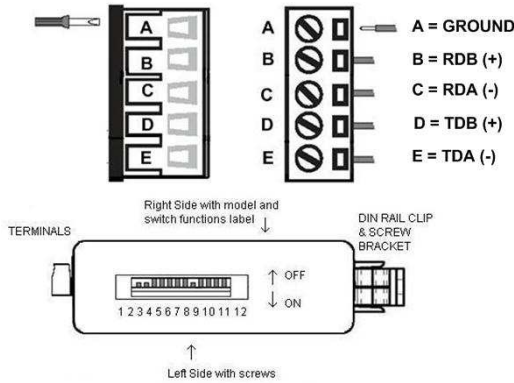

**DIP Switch SW-1**

1	2	3	4	5	6	7
ON	OFF	OFF	OFF	X	Y	Z

POSITIONS 8 THROUGH 12 ARE USED TO SET THE BAUD RATE.

1. Loosen the screws to open the TB lead clamps for the A, B, C, D, and E terminals.
2. Insert the RS-485 4-Wire signal leads. The terminal board accepts 28 to 14 AWG wire.
3. Tighten the screws to close the TB lead clamps. Ensure the clamps hold the leads securely. However, do not over tighten. For Class 1 DIV 2 installations, ensure the wiring is in accordance with the special precautions and the specification table.
4. Configure the DIP Switch on the bottom of the converter for RS-485 2-Wire operation (see above).
  - X. ON = Termination IN  
OFF = Termination OUT
  - Y. ON = TX Bias IN  
OFF = TX Bias OUT
  - Z. ON = RX Bias IN  
OFF = RX Bias OUT

**Installation Notes:**

- If Termination is required, a 120Ω resistor can be placed across the D and E terminals by setting SW1-5 to ON.
- This converter has 1.2 KΩ pull-up/down bias resistors built in. To use this bias, set SW1-6 and SW1-7 to ON.
- B&B Electronics' RS-485 Application Note contains more information about termination and biasing. This reference is available on our web site.

## RS-422 (Full Duplex)

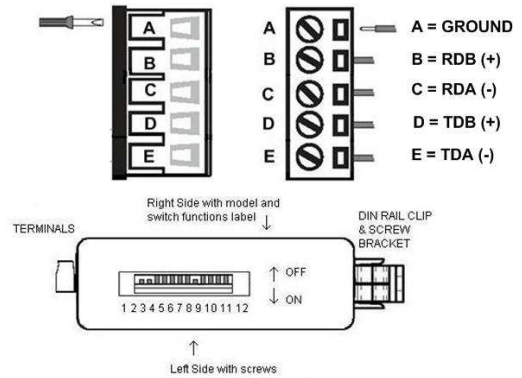

**DIP Switch SW-1**

1	2	3	4	5	6	7
OFF	OFF	OFF	OFF	X	Y	Z

POSITIONS 8 THROUGH 12 ARE USED TO SET THE BAUD RATE.

1. Loosen the screws to open the TB lead clamps for the A, B, C, D, and E terminals.
2. Insert the RS-422 signal leads. The terminal board accepts 28 to 14 AWG wire.
3. Tighten the screws to close the TB lead clamps. Ensure the clamps hold the leads securely. However, do not over tighten. For Class 1 DIV 2 installations, ensure the wiring is in accordance with the special precautions and the specification table.
4. Configure the DIP Switch on the bottom of the converter for RS-485 2-Wire operation (see above).
  - X. ON = Termination IN  
OFF = Termination OUT
  - Y. ON = TX Bias IN  
OFF = TX Bias OUT
  - Z. ON = RX Bias IN  
OFF = RX Bias OUT

**Installation Notes:**

- If Termination is required, a 120Ω resistor can be placed across the D and E terminals by setting SW1-5 to ON.
- This converter has 1.2 KΩ pull-up/down bias resistors built in. To use this bias, set SW1-6 and SW1-7 to ON.
- B&B Electronics' RS-485 Application Note contains more information about termination and biasing. This reference is available on our web site.

## Power

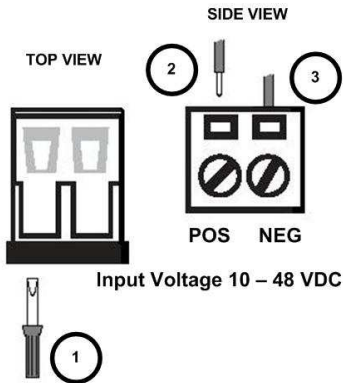

1. Loosen the screw to open the terminal block lead clamp.
2. Insert the power lead. TB will accept 28 to 14AWG wire.
3. Tighten the screw to close the terminal block lead clamp. Ensure the clamp holds the lead securely. However, do not over tighten. For Class 1 DIV 2 installations, ensure wiring is in accordance with the special precautions and specification table.

## Loop Back Test

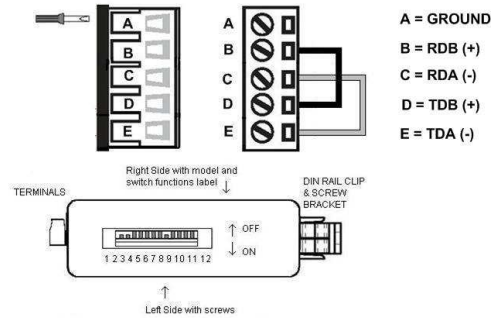

DIP Switch SW-1

1	2	3	4	5	6	7
ON	OFF	OFF	OFF	OFF	OFF	OFF

POSITIONS 8 THROUGH 12 ARE USED TO SET THE BAUD RATE.

1. Configure the converter for RS-485 4-Wire mode and the desired baud rate.
2. Place a jumper wire between the B and D terminals and the C and E terminals.
3. Connect a PC to the RS-232 port.
4. Using Hyper Terminal or similar program, connect to the appropriate COM port. Set the baud rate to match the converter. Ensure Hyper Terminal local echo is OFF.
5. Transmit data. If the same data is returned, the test is good.

## Mechanical Diagram

