

## Port Powered RS-232 to RS-485 Converter

Model 485LP9TBN



The 485LP9TBN is a port-powered two-channel RS-232 to RS-485 converter. It converts TD and RD RS-232 lines to balanced RS-485 signals. The unit can be powered from the RS-232 handshake lines, DTR and RTS. One of these handshakes must be high (asserted) to power the unit (See Table 1). DTR must be asserted to receive data. The RS-485 driver is enabled when RTS is asserted and disabled when RTS is disasserted. The RS-485 receiver is disabled when the driver is enabled and is enabled when the driver is disabled.

In order to maximize the amount of power available to the RS-485 driver, the RS-232 **handshake lines are not looped back** (tied together). As a result the following handshake lines will appear as disasserted (low): CTS, DCD, and DSR. Care should be taken to insure that any software being used doesn't require any of these handshake lines be asserted. If existing software requires any of the handshake lines to be asserted, you can loop back the required handshake lines in your cable.

Table 1

RTS State	DTR State	Functions Possible (when port powering unit)
Low	Low	none
Low	High	Receive
High	Low	Transmit
High	High	Transmit

\* NOTE: Low = disasserted and High = asserted

### Connections

A typical two wire RS-485 connected is shown in Figure 1. Regardless of the system, the 485LP9TBN must be connected with the proper polarity. With no data is being sent and the driver enabled, the RS-232 line should be negative and the TD(A) should be negative with respect to TD(B).

Proper operation of any RS-485 system requires the presence of a signal return path between the signal grounds of the equipment at each end of an interconnection. This circuit reference may be established by a third conductor connecting the common leads of devices, or it may be provided by connections in each equipment to an earth reference. When the circuit reference is provided by a third conductor, the connection between the signal grounds and the third conductor should contain some resistance (e.g. 100 ohms) to limit circulating currents when other ground connections are provided for safety.

Figure 1

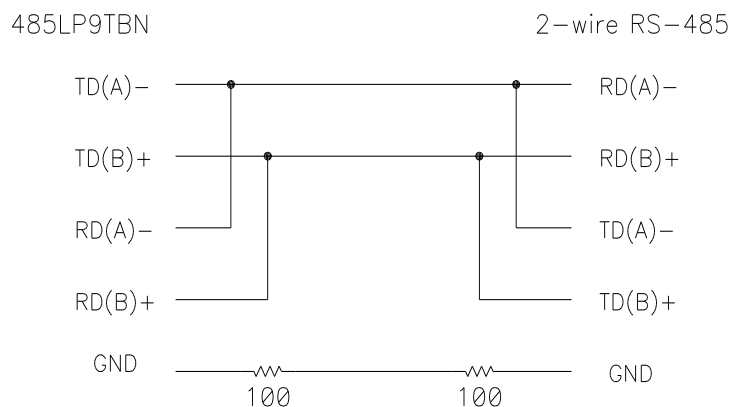

**Biasing Resistors**

The biasing resistors for the RS-422/RS-485 receiver are 4.7K Ohm resistors. These resistors are labeled R1 and R6 (See Figure 2). Refer to B&B Electronics RS-422/485 Application Note for further information on biasing.

Figure 2

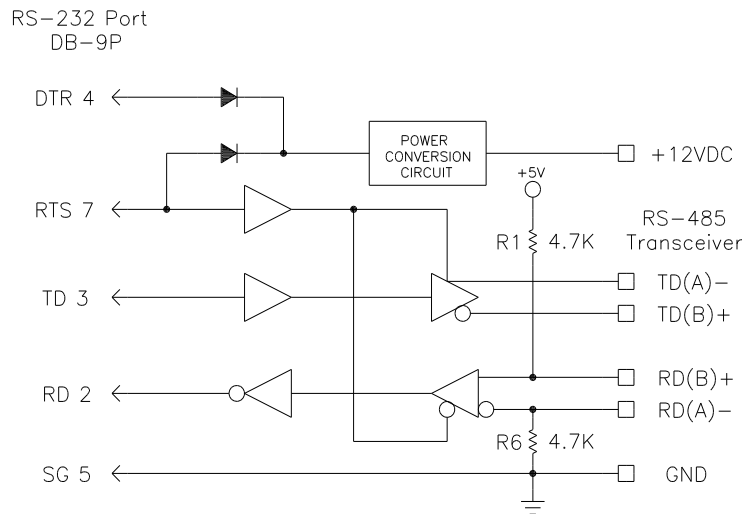

**Specifications**

Data Rate: 115.2K Baud max.

Power: Port Powered from RTS and DTR.

NOTE: If external power is required, use a source that can supply 12 to 16VDC at 40mA

**NOTE: When using an external supply, the supply should be connected only to specifically labeled power inputs (power jack, terminal block, etc.). Connecting an external power supply to the handshake lines may damage the unit. Contact technical support for more information on connecting an external power supply to the handshake lines.**

DECLARATION OF CONFORMITY	
Manufacturer's Name:	B&B Electronics Manufacturing Company
Manufacturer's Address:	P.O. Box 1040 707 Dayton Road Ottawa, IL 61350 USA
Model Numbers:	485LP9TBN
Description:	Port-Powered RS-232 to RS-485 Converter
Type:	Light industrial ITE equipment
Application of Council Directive:	89/336/EEC
Standards:	EN 50082-1 (IEC 801-2, IEC 801-3, IEC 801-4) EN 50081-1 (EN 55022, IEC 1000-4-2) EN 61000 (-4-2, -4-3, -4-4, -4-5, -4-6, -4-8, -4-11) ENV 50204 EN 55024
 Robert M. Paratore, Director of Engineering	
