

WEBS-1341

Embedded rugged fan-less system with Intel® Atom™ N455/D525 based 3.5" ECX board

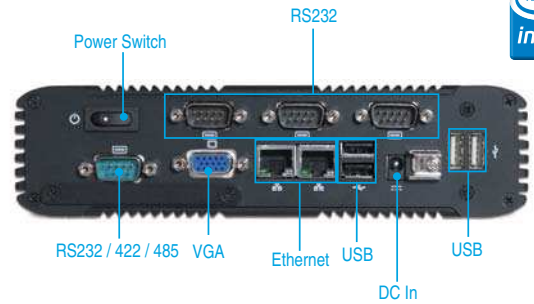
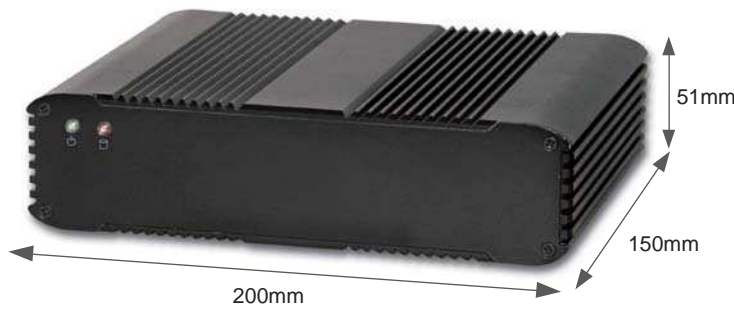

The WEBS-1341 takes advantage of the latest Intel® Atom™ technologies. It supports DDR3 SDRAM, dual gigabit ethernet and one expansion Mini PCI Express x1 socket. Based on Intel® Atom™ solutions, the fanless WEBS-1341 executes high performance with low power dissipation. Therefore, it's applied to, Kiosk, DS, and industrial automation.

FEATURES

- Fan-less solution with Dual-Core CPU
- Intel® Atom™ N455/D525 1.6/1.8GHz processor and Intel® ICH8-M chipset
- One Mini-PCIExpress expansion and Antenna hole
- Rich I/O is good for versatile applications
- Rugged and compact design for harsh environment
- Versatile mounting solutions such as Wall and Panel mount (Optional)
- Single DC 12V power input for easy system intergation
- One Mini-PCI Express expansion
- OP Vibration: 5Grms/5~500Hz
- OP Shock:50G, 11 msec.
- IP40 Rating

ORDERING GUIDE

AS5-3271	(R).ATO.WEBS-1341. 3.5" ECX System.PEB-2771VG2A/2781VG2A. DDR3. 40W Adapter
----------	--------------------------------------------------------------------------------

System

Board Dimension	PEB-2771/2781
System Chipset	Intel® ICH8-M
CPU	Intel® Atom N455 (1.6GHz)/D525 (1.8GHz) processor
FSB	800 MHz
BIOS	AMI BIOS
System Memory	One 204-pin SODIMM support DDR3 up to 2GB
Storage	1× CF, 1× SATA 2.5" HDD
Watchdog Timer	Programmable via S/W from 1 sec. to 255 min.
H/W Status Monitor	Temperature (CPU and System), Voltage
Expansion	1× Mini-PCIe socket

External I/O

Serial Port	3× RS232 + 1× RS232/422/485
Display	1× VGA
USB	4× USB 2.0
Ethernet	2× Gigabit Ethernet (82567V + 82583V)
Others	Removeable CF card; Internal header for Audio (ALC262)

Power Supply Unit

Power Input	DC 12V
Adaptor	AC 100~240V

Environmental

Operation Temperature	-5~45°C
Storage Temperature	-20~80°C
Relative Humidity	95%@40°C, non-condensing
Operation Vibration	5Grms/5~500Hz, IEC 60068-2-27
Operation Shock	50G, 11 msec., IEC 60068-2-27

Mechanical

Dimension	200(W) × 150(D) × 51(H)mm; 7.9"(W) × 5.9"(D) × 2"(H)
Weight	1.6 kg
Mounting	Desk, Wall/Panel-mounting

