

PA-H8/338-(T)80 Data Sheet

80 pin QFP(TQFP) socket/32 pin DIP 0.6" plug

Supported Device/Footprints

These adapters allow EPROM programming of Hitachi H8/337 and H8/338 devices in their QFP or TQFP packages on 32 pin DIP programmers.

Mfgr	Device		Footprint	
	Device	Package	Device	Plug
Hitachi	H8/337, H8/338	QFP or TQFP	27010	32 pin DIP

These adapters are direct replacements for Hitachi programming adapters. A cross reference follows along with Hitachi package codes and device body size and lead pitch.

LSC Adapter #	LSC Pkg	Hitachi Adapter	Hitachi Pkg code	Body (square)	Pitch (mm)
PA-H8/338-80	QFP	HS338ESH02H	FP-80A	14mm	0.65
PA-H8/338-T80	TQFP	unknown	TFP-80A	12mm	0.5

Adapter Dimensions

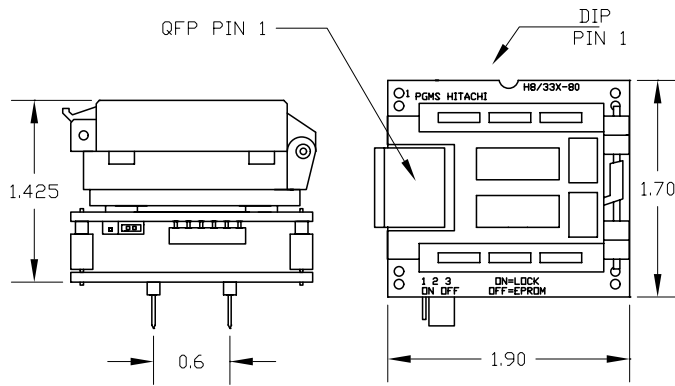

PA-H8/338-80

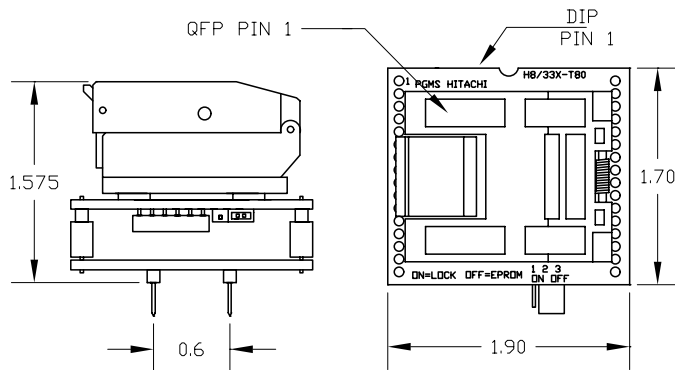

PA-H8/338-T80

Adapter Parts & Part Numbers

The following chart shows the various socket and board part numbers that make up these adapters.

Adapter	Socket	Top Board	Bottom Board
PA-H8/338-80	80QG-02A	H8/33X-80	H8/53X-32
PA-H8/338-T80	80QJ-808	H8/33X-T80	H8/53X-32

Adapter Construction

The adapter is made up of 3 sub-assemblies. They assemble via connectors making the adapter modular. This way the sub-assemblies can be replaced when they wear out.

When disassembling the adapter take care not to bend the pins. When reassembling the adapter note the pin 1 indicators to align the parts correctly.

Test Socket

QFP Lidded ZIF test socket:

Enplas Part #: FPQ-80-0.65-02 LSC Part #: 80QG-02A

TQFP Lidded ZIF test socket:

Yamaichi Part #: IC51-0804-808 LSC Part #: 80QJ-808

H8/33X-(T)80

Accepts the test socket and connects to the 32 pin, 27C010 header. Provides circuitry for security programming.

H8/53X-32

Connects the top board to the programmer.

EPROM Security

The H8 family provides EPROM security. By programming one security location four EPROM bytes are protected. After programming, the protected bytes read 00h and cannot be programmed.

To program security locations, set the security jumper ON and program the device; the data value is ignored. The security jumper is marked SW1 on the top board.

SW1 jumper setting

Pins	Mode	Function
1-2	ON	Program Lock Bits
2-3 or none	OFF	Program/ Read EPROM

To secure the whole device simply set SW1 to ON and program the whole device to 00.

To secure one block of EPROM (4 bytes) program any byte of the block with SW1 ON. The block addresses begin at 0, and are arranged at 0-3, 4-7, 8-B, C-F and so on through all the memory.

The security locations are EPROM. On erasable devices they are erased when the EPROM is erased. On One-Time Programmable devices they cannot be erased.



Logical Systems Corporation
PO Box 6184, Syracuse, NY 13217-6184 USA
Tel (315) 478-0722, FAX (315) 479-6753
S Y S T E M S www.logicals.com, Email: info@logicals.com

PA-H8/338-(T)80 Data Sheet
Doc: H8338-80.DOC
Rev 01/11/01
Page 1 of 2

EPROM Address Mapping

The H8's EPROM is at the same address for MCU mode (normal execution) and EPROM programming. The valid EPROM addresses for each device are as follows.

Device	EPROM size	EPROM addresses	MCU addresses
H8/337	32K bytes	0000-7FFF	0000-7FFF
H8/338	48K bytes	0000-BFFF	0000-BFFF

These devices have less memory than the standard EPROM they emulate. The following table shows the device, its EPROM programming footprint, and the unused addresses of that footprint. Those unused addresses can be accessed by the EPROM programmer. When those addresses are read the value will be either FF or undetermined. When programming, either prevent those addresses from being programmed or be sure to set the data for those unused addresses to FF.

Device	Footprint	Unused Addresses	Reads	Program to
H8/337	27C010	0,8000-1,FFFF	??	FF
H8/338	27C010	0,C000, 1,FFFF	??	FF

Adapter Wiring

The following chart shows the connections from the QFP device to the adapter's DIP plug.

SOCKET	PLUG	SOCKET	PLUG
1	1	41	-
2	-	42	-
3	-	43	-
4	16	44	-
5	16	45	-
6	26	46	-
7	16	47	32
8	32	48	22
9	-	49	29
10	-	50	28
11	-	51	4
12	16	52	25
13	-	53	23
14	-	54	24
15	-	55	27
16	-	56	16
17	-	57	5
18	31	58	6
19	3	59	7
20	2	60	8
21	-	61	9
22	-	62	10
23	-	63	11
24	10K +	64	12
25	10K +	65	13
26	-	66	14
27	-	67	15
28	-	68	17
29	32	69	18
30	-	70	19
31	-	71	20
32	-	72	21
33	-	73	16
34	-	74	32
35	-	75	SW1-2
36	-	76	-
37	-	77	-
38	16	78	-
39	-	79	-
40	-	80	-

VCC (32) to GND (16) .1uf bypass

10K + 10K Pullup

SW1 Jumper settings:

1-2 for ON (Program Lock Bits)

2-3 (or none) OFF (Program/Read EPROM)

