

Audio Modulated Matrix LED Driver

Description

SN3728 is a general purpose 8×8 LED matrix driver which features an audio frequency equalizer (EQ) mode or a general LED dot matrix display mode. The general LED matrix display defaults to an 8×8 configuration, however, it can be configured for a 5×11, 6×10, 7×9 dot matrix display. The matrix picture brightness can be modulated by audio. In either the audio EQ mode or matrix display mode, the array is internally scanned, and requires only one-time programming, thus eliminating the need for real time system resource utilization.

It programs the LED array through I2C interface. In the general purpose display mode, each dot of the LED array is independently programmed on or off over time. In the audio EQ mode, the X axis (column) represents the frequency bands while the Y axis (row) represents the strength of the input audio signal in each band. The number of LEDs lit in a column is proportional to the strength of the audio signal in the corresponding band in a thermometer-coded manner.

SN3728 is available in QFN-24(4mm × 4mm). It operates from 2.7V to 5.5V over the temperature range of -40°C to +85°C.

Features

- 5~8 current source outputs for row control
- 8~11 outputs for column scan control
- Programmable 8×8, 7×9, 6×10, 5×11 matrix
- One-time programming, internal scan
- Full scale LED current controlled by internal register setting or audio signal
- Audio frequency EQ display with programmable input gain
- LED matrix brightness can be modulated with audio Signal
- One address pin with 4 logic levels to allow four I2C slave addresses
- I2C interface
- 2.7V to 5.5V supply
- Over-temperature protection
- QFN -24(4mm × 4mm) package

Applications

- Mobile phones and other hand-held devices for LED displays.
- Audio frequency equalizer display

Typical Application Circuit

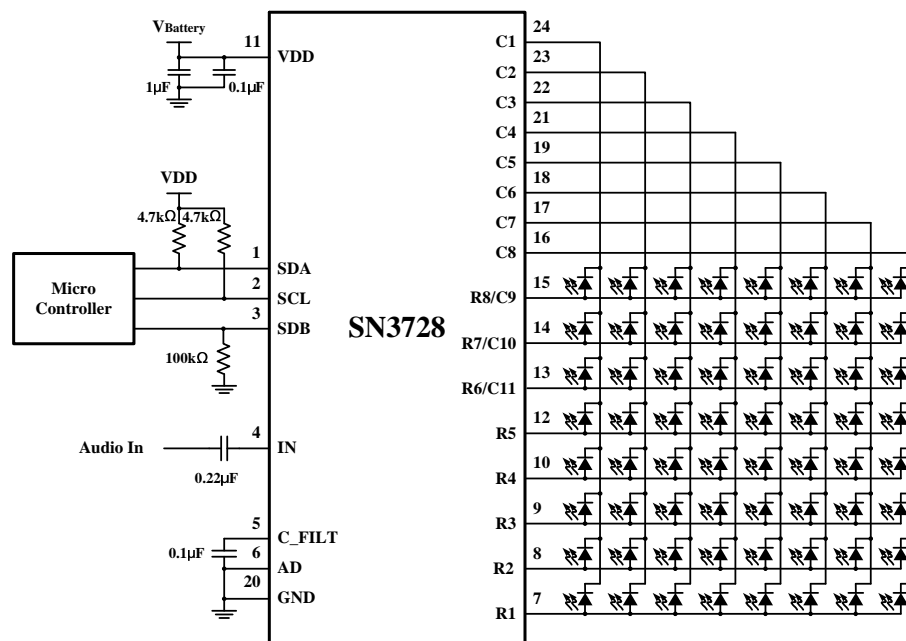
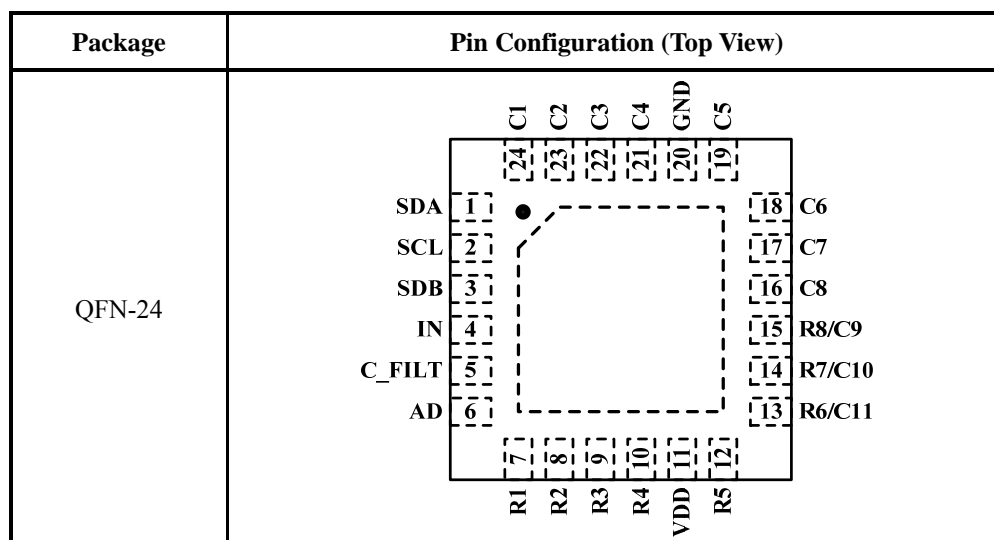

Figure 1 Typical Application Circuit

Pin Configuration



Pin Description

No.	Pin	I/O	Description
1	SDA	I/O	Serial data.
2	SCL	I	Serial clock.
3	SDB	I	Shutdown the chip when pull to low.
4	IN	I	Audio input.
5	C_Filt	I	Low pass filter cap for audio control.
6	AD	I	I2C Address setting.
7~10, 12	R1~R5	O	Current source outputs.
11	VDD	-	Power supply.
13~15	R6/C11, R7/C10, R8/C9	O	CMOS outputs.
16~19, 21~24	C8~C1	O	Current sink outputs.
20	GND	-	Ground.
	Thermal Pad	-	Connect to GND.

Ordering Information

Order Number	Package Type	QTY/Reel	Operating Temperature Range
SN3728I424E	QFN-24	2500	-40°C ~ +85°C

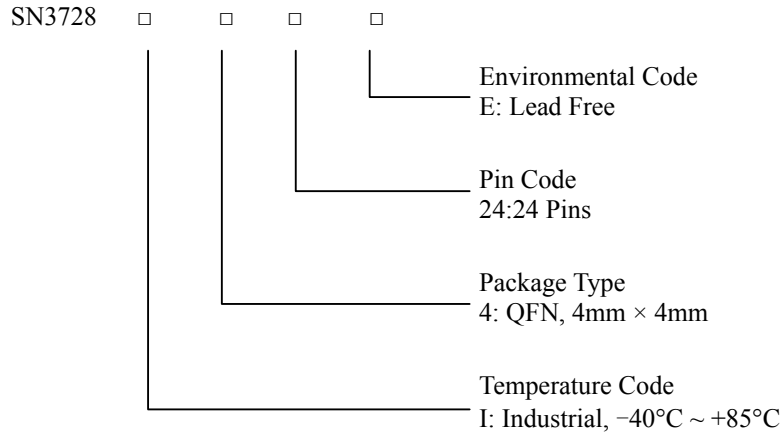

Absolute Maximum Ratings

Supply voltage, V_{DD} -----	-0.3 V ~ +6.0V
Voltage at any input pin -----	-0.3V ~ $V_{DD}+0.3V$
Junction temperature, T_{JMAX} -----	150°C
Thermal resistance, θ_{JA} (QFN-24) -----	27.7°C/W

Stresses beyond those listed under “Absolute Maximum Ratings” may cause permanent damage to the device. These are stress ratings only and functional operation of the device at these or any other condition beyond those indicated in the operational sections of the specifications is not implied. Exposure to absolute maximum rating conditions for extended periods may affect device reliability.

Electrical Characteristics

$T_A = -40^\circ\text{C} \sim +85^\circ\text{C}$, unless otherwise noted. Typical value are $T_A = +25^\circ\text{C}$.

Symbol	Parameter	Condition	Min.	Typ.	Max.	Unit
V_{DD}	Supply voltage		2.7		5.5	V
I_{DD}	Quiescent power supply current	$V_{IN} = 0V$, register CD1:CD11 = 0 dot matrix display mode without audio modulation		4.1	5.0	mA
I_{SD}	Shutdown current	$V_{SDB} = 0V$		0.2	1.0	μA
		$V_{SDB} = 5V$, software shutdown		1.7	3.0	μA
I_{OUT}	Output current of R1~R8	Dot matrix display mode without audio modulation		42.8 (Note 1)		mA
		Dot matrix display mode with audio modulation $V_{IN} = 1.8V_{p-p}$, 1kHz square wave, audio gain = 0dB		42.3 (Note 1)		mA
V_{HR}	Current sink (I_{SINK} , C1:C8) headroom voltage and current source (I_{OUT} , R1:R8) headroom voltage	$I_{SINK} = 320\text{mA}$ (Note 2)		300		mV
		$I_{OUT} = 40\text{mA}$		200		
Logic Electrical Characteristics						
$V_{IN(0)}$	Logic “0” input voltage	$V_{DD} = 2.7V$			0.4	V
$V_{IN(1)}$	Logic “1” input voltage	$V_{DD} = 5.5V$	1.4			V
$I_{IN(0)}$	Logic “0” input current	$V_{IN} = 0V$		5 (Note 3)		nA
$I_{IN(1)}$	Logic “1” input current	$V_{IN} = V_{DD}$		5 (Note 3)		nA

Digital Input Switching Characteristics (Note 3)

Symbol	Parameter	Condition	Min.	Typ.	Max.	Unit
f_{SCL}	Serial-Clock Frequency				400	kHz
t_{BUF}	Bus Free Time Between a STOP and a START Condition		1.3			μ s
$t_{HD, STA}$	Hold Time (Repeated) START Condition		0.6			μ s
$t_{SU, STA}$	Repeated START Condition Setup Time		0.6			μ s
$t_{SU, STO}$	STOP Condition Setup Time		0.6			μ s
$t_{HD, DAT}$	Data Hold Time				0.9	μ s
$t_{SU, DAT}$	Data Setup Time		100			ns
t_{LOW}	SCL Clock Low Period		1.3			μ s
t_{HIGH}	SCL Clock High Period		0.7			μ s
t_R	Rise Time of Both SDA and SCL Signals, Receiving	(Note 4)		$20 + 0.1Cb$	300	ns
t_F	Fall Time of Both SDA and SCL Signals, Receiving	(Note 4)		$20 + 0.1Cb$	300	ns

Note 1. Current of single LED in $R_x(x=1\sim 8)$ is $I_{OUT}/8$.

Note 2. All row drivers are ON.

Note 3. Guaranteed by design.

Note 4: C_b = total capacitance of one bus line in pF. $I_{SINK} \leq 6mA$. t_R and t_F measured between $0.3 \times V_{CC}$ and $0.7 \times V_{CC}$.

Detailed Description

I2C Interface

The SN3728 uses a serial bus, which conforms to the I2C protocol, to control the chip's functions with two wires: SCL and SDA. The SN3728 has a 7-bit slave address (A6:A0). The bit A1 and bit A0 are decided by the connection of AD pin.

The complete slave address is:

Table 1 Slave Address (Write only)

AD connects to	A6:A2	A1	A0	R/W
GND	11000	0	0	0 (write only)
VDD		1	1	
SCL		0	1	
SDA		1	0	

The SCL line is uni-directional. The SDA line is bi-directional (open-collector) with a pull-up resistor (typically 4.7kΩ). The maximum clock frequency specified by the I2C standard is 400 kHz. In this discussion, the master is the microcontroller and the slave is the SN3728.

The timing diagram for the I2C is shown in Figure 3. The SDA is latched in on the stable high level of the SCL and the SDA line should be held high when not in use.

The "start" signal is generated by lowering the SDA signal while the SCL signal is high. The start signal will

alert all devices attached to the I2C bus to check the incoming address against their own chip address.

The 8-bit chip address is sent next, most significant bit first. Each address bit must be stable while the SCL level is high.

After the last bit of the chip address is sent, the master checks for the SN3728's acknowledge. The master releases the SDA line high (through a pull-up resistor). Then the master sends an SCL pulse. If the SN3728 has received the address correctly, then it holds the SDA line low during the SCL pulse. If the SDA line is not low, then the master should send a "stop" signal (discussed later) and abort the transfer.

Following acknowledge of SN3728, the register address byte is sent, most significant bit first. SN3728 must generate another acknowledge indicating that the register address has been received.

Then 8 bits of data byte is sent, most significant bit first. Each data bit should be valid while the SCL level is stable high. After the data byte is sent, the SN3728 must generate another acknowledge indicating that the data has been received.

If the master has more data bytes to send to the SN3728, then the master can repeat the previous two steps until all data bytes have been sent.

The "stop" signal ends the transfer. To signal "stop", the SDA signal goes high while the SCL signal is high.

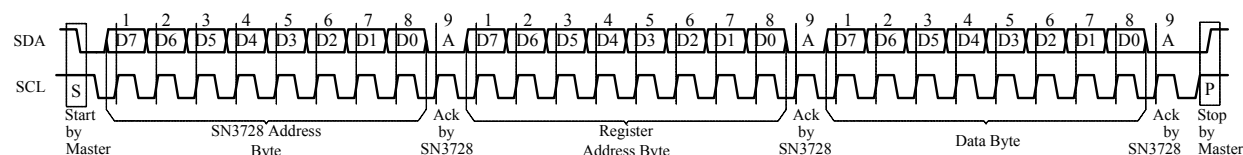

Figure 2 Writing to SN3728

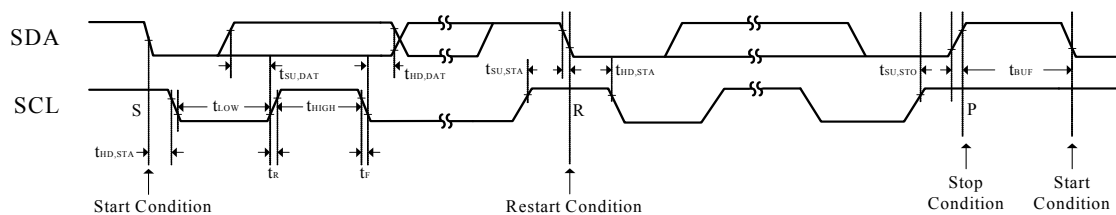

Figure 3 Interface Timing

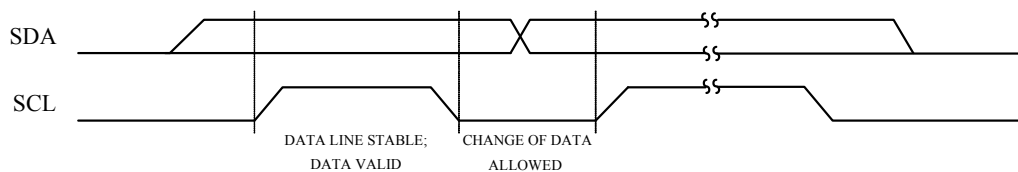

Figure 4 Bit Transfer

Registers Definition**00h Configuration Register**

Bit	D7	D6:D3	D2	D1	D0
Name	SSD	-	Audio_EN	ADM	
Default	0	0000	0	0	0

The Configuration Register sets operation mode of SN3728.

SSD Software Shutdown Enable
 0 Normal Operation
 1 Software Shutdown Mode

Audio_EN Audio Input Enable
 0 Matrix Intensity is Controlled By The Current Setting In The Lighting Effect Register (0Dh)
 1 Enable Audio Signal To Modulate The Intensity Of The Matrix In Dot Matrix Display Mode

ADM Array Mode Selection
 00 8×8 Dot Matrix Display Mode
 01 7×9 Dot Matrix Display Mode
 10 6×10 Dot Matrix Display Mode
 11 5×11 Dot Matrix Display Mode

01h~0Bh Column Data Register (CD1~CD11)

Bit	D7:D0
Name	R8:R1
Default	00000000

The column data registers store the on or off state of each LED in the array.

R_x LED State
 0 LED Off
 1 LED On

The data in the column data registers is valid only when the chip is configured in general purpose dot matrix display mode. 11 registers are assigned to CD1~CD11 columns respectively; the LED at a particular (row, column) location will be turned on when the respective data is set to 1. When configured to other than 8×8 dot matrix display mode operation, only the required number of LSBs is used in each column register. For example, in 5×11 dot matrix display mode, only bits R5 through R1 are used, and bits R8 through R6 are ignored.

0Ch Update Column Register

The data sent to the column data registers will be stored in temporary registers. A write operation of any 8-bit value to the Update Column Register is required to update the Column Data Registers (01h : 0Bh).

0Dh Lighting Effect Register

Bit	D7	D6:D4	D3:D0
Name	-	AGS	CS
Default	0	000	0000

The Lighting Effect Register stores the intensity control settings for all of the LEDs in the array

AGS Audio Input Gain Selection
 000 0dB
 001 +3dB
 010 +6dB
 011 +9dB
 100 +12dB
 101 +15dB
 110 +18dB
 111 -6dB

CS Full Current Setting For Each Row Output
 0000 40mA
 0001 45mA

 0111 75mA
 1000 5mA
 1001 10mA

 1110 35mA

0Fh Audio_EQ Register

Bit	D7	D6	D5:D0
Name	-	AE_EN	-
Default	0	0	000000

The Audio_EQ Register enables the audio frequency equalizer (audio EQ) mode

AE_EN Audio EQ Mode
 0 Disable
 1 Enable

Application Information

Audio Frequency Equalizer (Audio EQ) Mode

The SN3728 features audio frequency equalizer mode, or audio EQ mode.

The current of the matrix is adjusted by Lighting Effect Register as dot matrix display mode.

In the audio EQ mode, only 8 columns are valid and display the three bands of the audio signal. When the SN3728 is configured as 7×9, 6×10 or 5×11, only columns C1 thru C8 will be used, and the remaining columns will always be off.

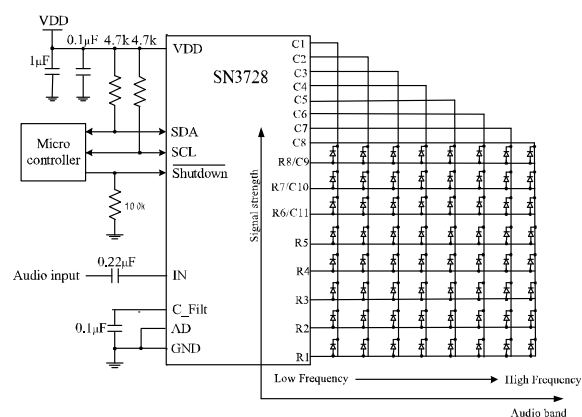

Figure 6 Audio EQ Mode

General Purpose Dot Matrix Display Mode

The general purpose dot matrix display timing diagram is shown in figure 7. The SN3728 is configured as general purpose 8×8 dot matrix display mode at initial power up. Column controls C[8:1] scans the eight columns at a rate of 3.79KHz, or 264µs per frame. Each column is effective for 32µs. The non-overlap interval between adjacent columns is 1µs.

The SN3728 also can be configured as 7×9, 6×10 or 5×11 dot matrix display mode. The frame period is changed slightly depending on the number of columns required to scan by an additional time of 33µs per column. For example, when in 7×9 dot matrix display mode, the column data registers' MSB will be invalid and column controls C[9:1] scans the nine columns 297µs per frame.

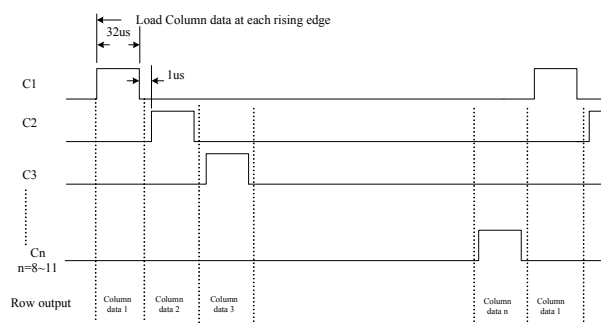

Figure 7 Dot Matrix Display Timing Diagram

8×8 Dot Matrix Display Mode

The application example in Figure 1 shows the SN3728 in the 8×8 LED dot matrix display mode.

The LED columns have common cathodes and are connected to the C1:C8 outputs. The rows are connected to the row drivers. Each of the 64 LEDs can be addressed separately. The columns are selected via the registers 01h~08h as described in the registers definition section.

5×11 Dot Matrix Display Mode

By setting D1&D0 of the Configuration Register to 11, the SN3728 will operate in the 5×11 LED dot matrix display mode.

The LED columns have common cathodes and are connected to the C1:C11 outputs. The rows are connected to the row drivers. Each of the 55 LEDs can be addressed separately. The three MSBs of each register, R8~R6, are ignored. The columns are selected via the registers as described in the registers definition section.

Dot Matrix Display Mode With Audio Modulation

When the SN3728 operates in any of the Dot Matrix modes, if the bit Audio_EN in Configuration register is set to 1, the panel will get the effect of audio modulation

Initial Power-Up

On initial power-up, the SN3728 registers are reset to their default values for a blank display. At this time, all registers should be programmed for the desired operation.

Software Shutdown Mode

The SN3728 devices feature a software shutdown mode, wherein they consume only 1.7 μ A (typ.) current. Shutdown mode is entered via a write to the Configuration Register. When the SN3728 is in shutdown mode, all current sources and digital drivers are switched off, so that the array is blanked.

Shutdown mode can either be used as a means of reducing power consumption or generating a flashing display (repeatedly entering and leaving shutdown mode).

Note: During shutdown mode all registers retain their data.

Classification Reflow Profiles

Profile Feature	Pb-Free Assembly
Preheat & Soak Temperature min (T _{sm}) Temperature max (T _{sm}) Time (T _{sm} to T _{sm}) (t _s)	150°C 200°C 60-120 seconds
Average ramp-up rate (T _{sm} to T _p)	3°C/second max.
Liquidous temperature (T _L) Time at liquidous (t _L)	217°C 60-150 seconds
Peak package body temperature (T _p)*	Max 260°C
Time (t _p)** within 5°C of the specified classification temperature (T _c)	Max 30 seconds
Average ramp-down rate (T _p to T _{sm})	6°C/second max.
Time 25°C to peak temperature	8 minutes max.

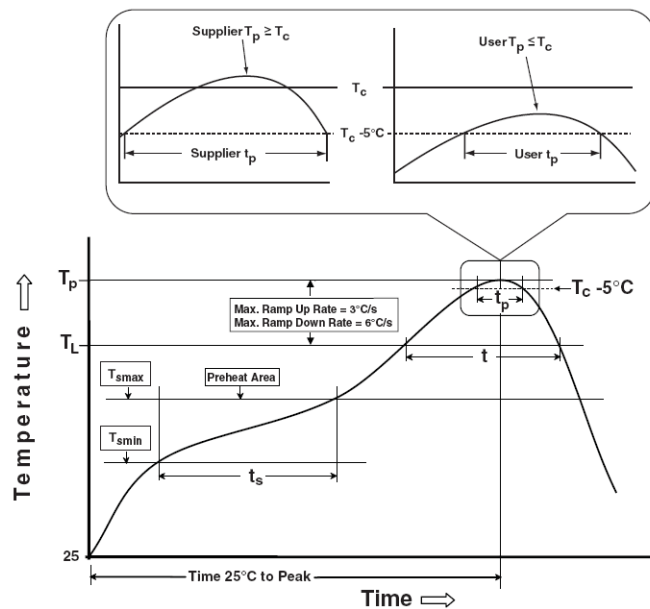
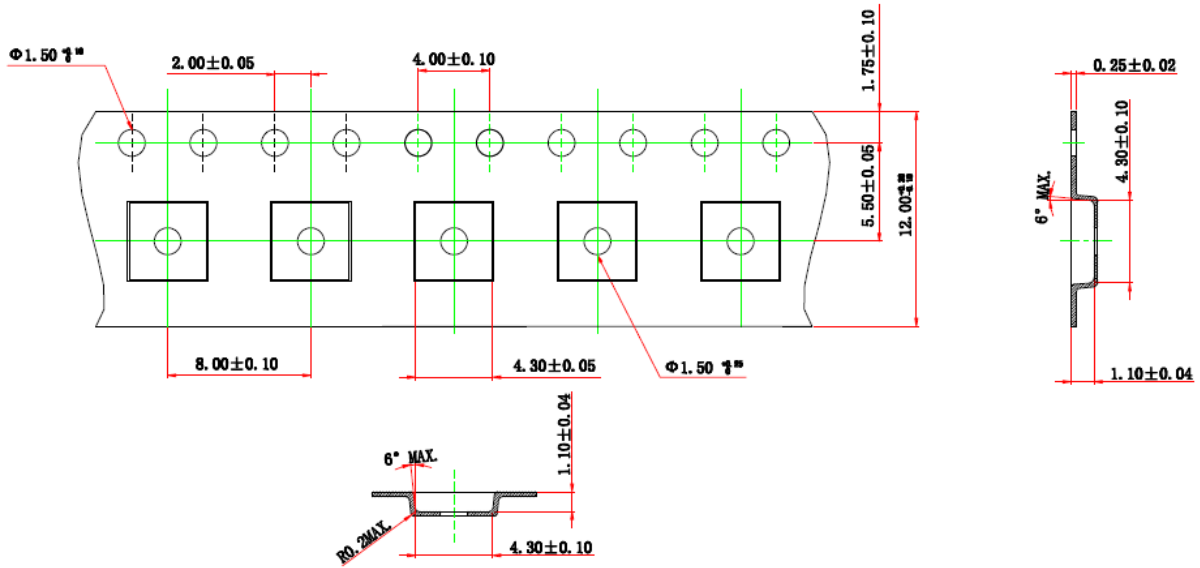

Figure 8 Classification Profile

Tape and Reel Information



NOTES:[技术要求]:

- 1.CARRIER TAPE COLOR:BLACK[载带颜色为黑色]
- 2.COVER TAPE WIDTH:8.50±0.10 [覆盖:8.5±0.10宽载带]
- 3.COVER TAPE COLOR:TRANSPARENT [盖带颜色无色透明]
4. ANTISTATIC COATED 10⁷~10⁸ OHMS/SQ.[单位面积表面阻抗为10⁷Ω/□~10⁸Ω/□]
- 5.10 SPROCKET HOLE PITCH CUMULATIVE TOLERANCE ±0.20MAX.
[10个传送定位孔间距累积公差0.20MAX.]
- 6.SUPPLIER:3M [供应商3M]
- 7.MOLD# W8PSP(4×4×0.75/0.85) [载带规格W8PSP(4×4×0.75/0.85)]
- 8.ALL DIMS IN mm.[所有单位为mm]
- 9.BAN TO USE THE LEVEL 1 ENVIRONMENT-RELATED SUBSTANCES OF JCET PRESCRIBING.
[禁止使用长电科技规定的一级环境管理物质]
- 10.THE DIRECTION OF VIEW: . [视图方向:
- 11.SPECIAL FOR CUSTOMER SHEN [矽基客户专用]

Package Information

QFN-24

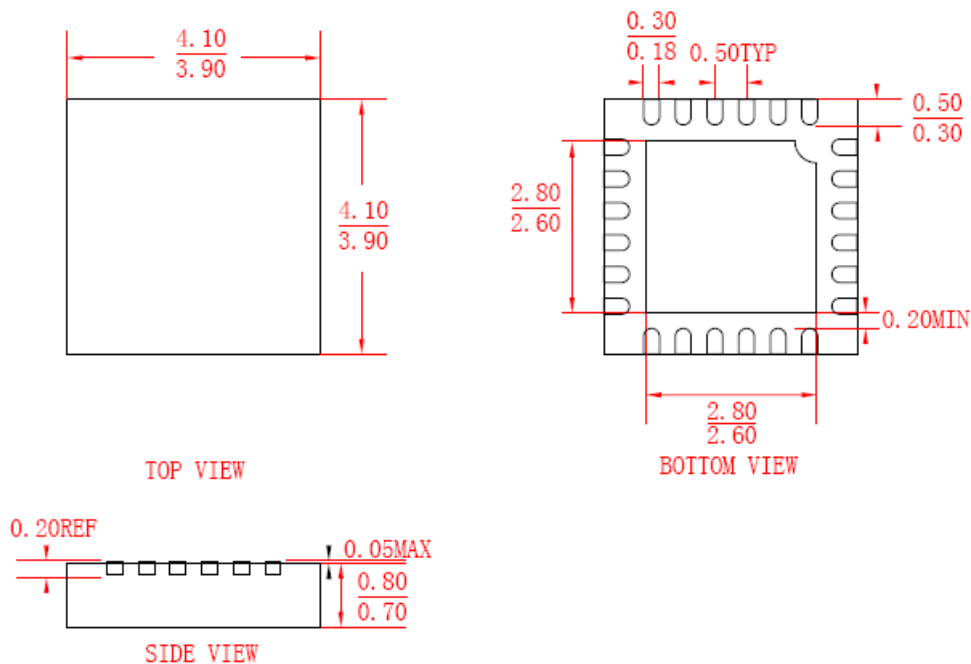

Note: All dimensions in millimeters unless otherwise stated.

IMPORTANT NOTICE

SI-EN Technology cannot assume responsibility for use of any circuitry other than circuitry entirely embodied in a SI-EN Technology product. SI-EN Technology reserves the right to make corrections, modifications, enhancements, improvements, and other changes to its specifications, products and services at any time and to discontinue any product or service without notice. Customers should obtain the latest relevant information before placing orders and should verify that such information is current and complete.