

White LED Driver

Description

The SN3228A (SN3228B) is a low noise, constant frequency charge pump DC/DC converter for white LED applications. The SN3228A (SN3228B) is capable of driving up to four (six) channels of LEDs at preset 20mA per channel from a 2.8V to 5.5V input. The current sinks may be operated individually or in parallel for driving higher current LEDs. Only one 1 μ F small capacitor (at C+ thru C-) and two small 2.2 μ F capacitors (at V_{CC} and V_{OUT}) are needed, it makes this part ideally suited for small, battery-powered applications.

The serial digital input is used to enable, disable, and set current for each LED with 14 settings down to 1.8mA. Each output of the SN3228A/SN3228B is equipped with built-in soft-start circuitry prevents excessive inrush current during start-up. A low-current shutdown feature disconnects the load from the input and reduces quiescent current to less than 3 μ A.

The SN3228A and SN3228B are available in a Pb-free, space-saving 2mm \times 2mm UTQFN-12 package.

Features

- V_{CC} range: 2.8V to 5.5V
- Fully programmable current with single wire –14 current levels
- Drives up to four (SN3228A)/six (SN3228B) channels of LEDs
- No inductors, low noise operation
- Built-in thermal protection
- Automatic soft start
- Low shutdown current: I_{SHDN} < 3 μ A
- UTQFN-12 (2mm \times 2mm) package

Applications

- Cell phone, smart phone, PDA
- Mp3, Mp4, PMP
- White LED backlighting

Typical Application Circuit

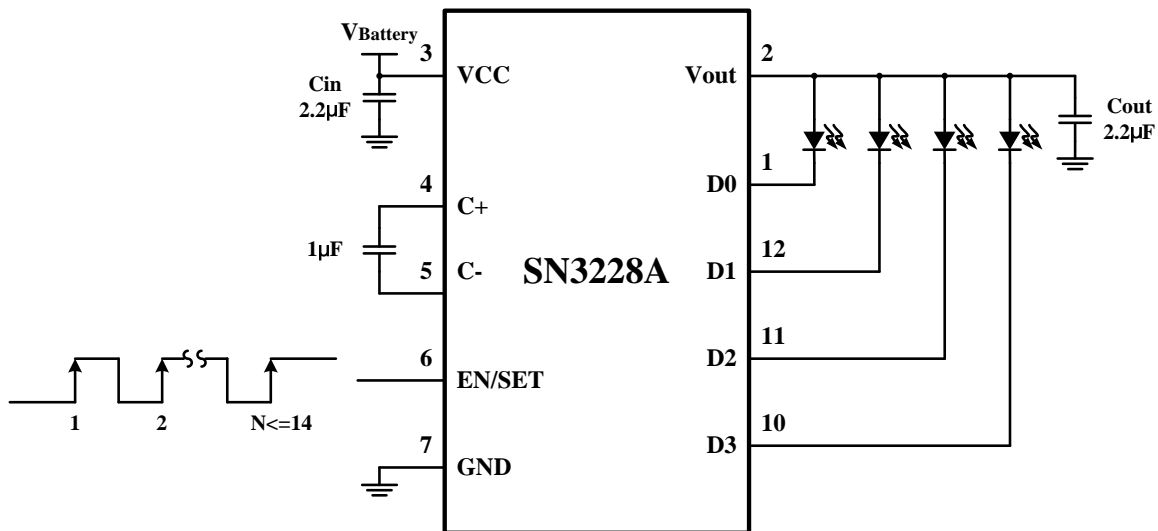

Figure 1 Typical Application Circuit (SN3228A)

Note: Cout can't be less than 2.2 μ F, and when less than six channels are used, keep the unused pin to GND or floating. But channel D0 (pin 1) has to be used.

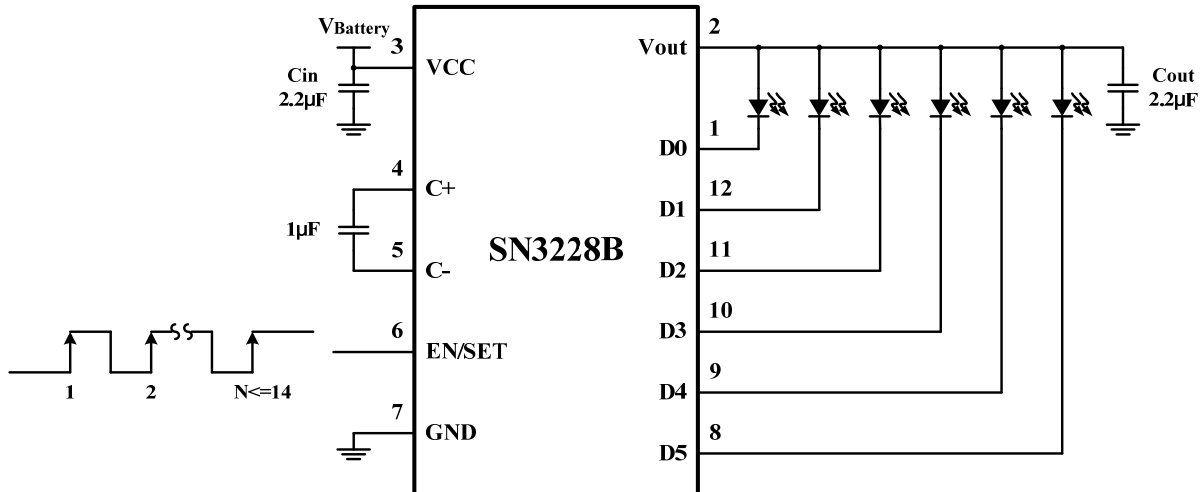

Figure 2 Typical Application Circuit (SN3228B)

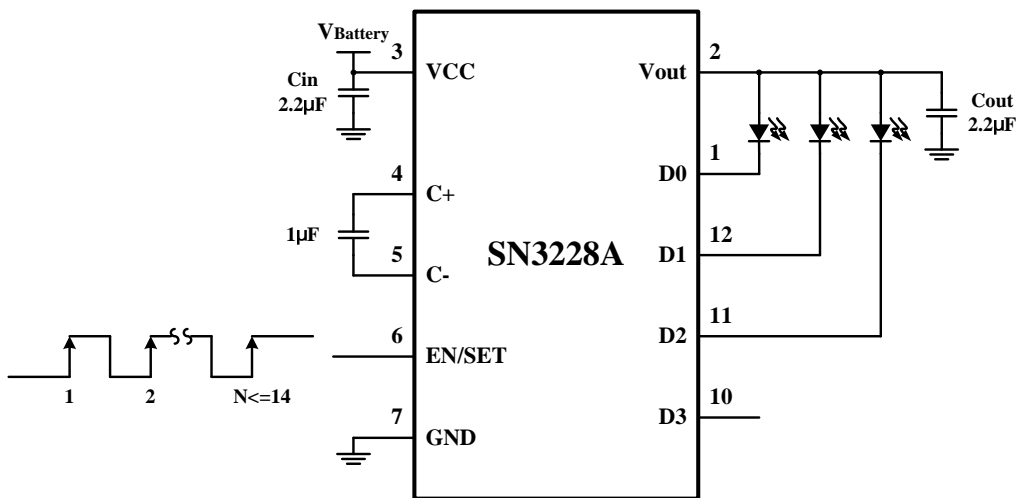

Figure 3 Application Circuit for Less Than 4 LEDs (SN3228A)

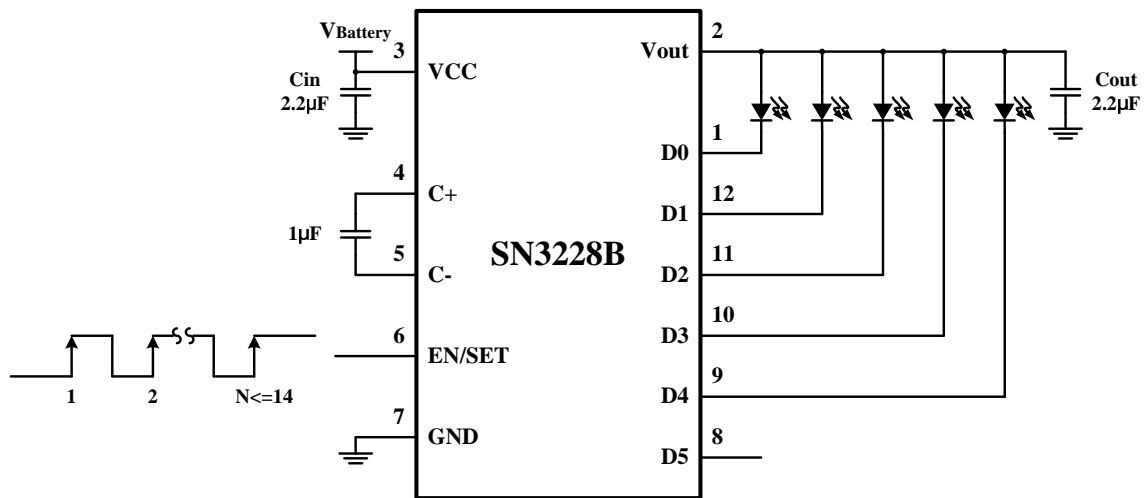
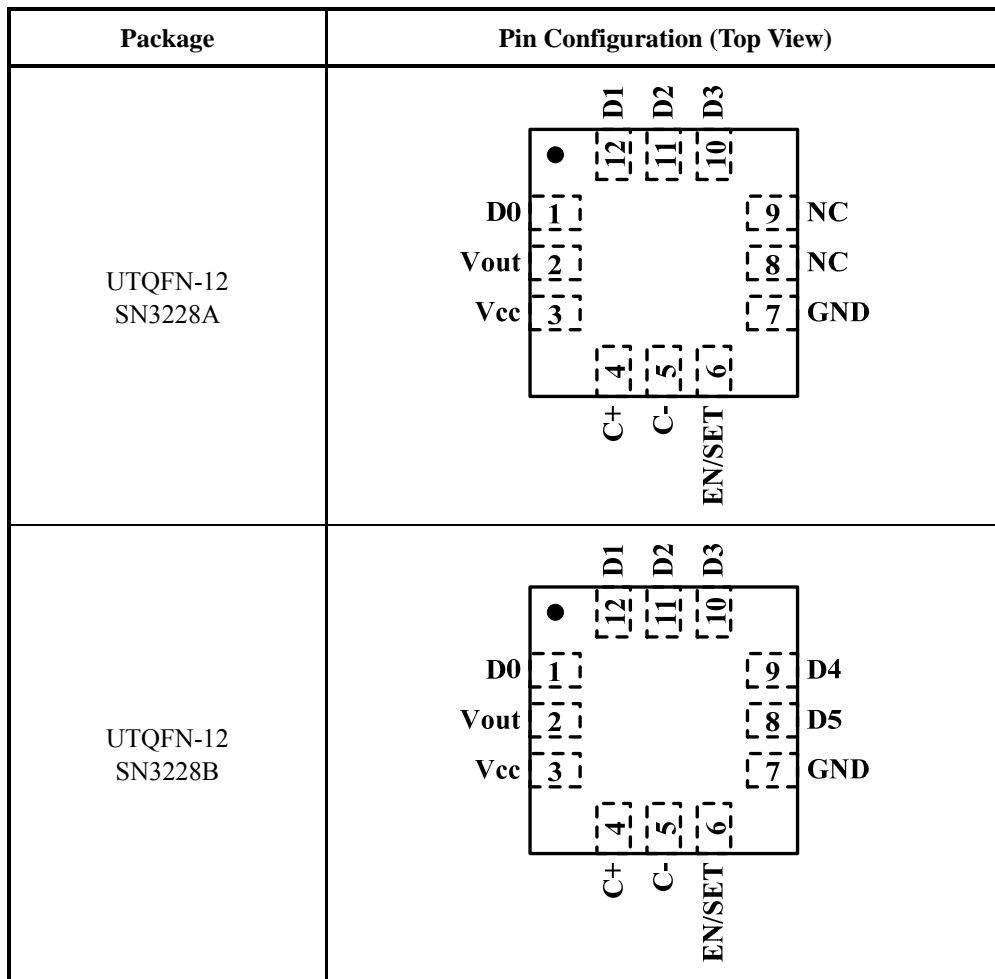

Figure 4 Application Circuit for Less Than 6 LEDs (SN3228B)

Pin Configuration



Pin Description

No.	SN3228A	SN3228B	I/O	Description
1	D0	D0	O	White LED channel, channel D0 must be used.
2	Vout	Vout	O	Charge pump output to drive load circuits, requires 2.2μF capacitor connected between this pin and ground pin.
3	Vcc	Vcc	–	Power supply input, requires 2.2μF capacitor connect between this pin and ground pin.
4	C+	C+	I	Flying capacitor positive terminal.
5	C–	C–	I	Flying capacitor negative terminal.
6	EN/SET	EN/SET	I	Serial digital input, control the output current.
7	GND	GND	–	Ground.
8, 9	NC	–	–	No connection.
	–	D5, D4	O	White LED channel 5 and channel 4.
10~12	D3~D1	D3~D1	O	White LED channel 3~1.

Absolute Maximum Ratings

Input voltage to GND, V_{CC} ----- -0.3 ~ +6.0V
 EN/SET voltage to GND, $V_{EN/SET}$ ----- -0.3 V ~ $V_{CC} + 0.3V$
 Junction temperature, T_J ----- -40 ~ +150°C
 Maximum soldering temperature (at lead, 10 sec), T_{LEAD} ----- 300°C
 ESD (Human Body Mode) ----- 3kV
 Maximum thermal resistance θ_{JA} (UTQFN-12) ----- 60°C/W

Stresses beyond those listed under “Absolute Maximum Ratings” may cause permanent damage to the device. These are stress ratings only and functional operation of the device at these or any other condition beyond those indicated in the operational sections of the specifications is not implied. Exposure to absolute maximum rating conditions for extended periods may affect device reliability.

Electrical Characteristics

$C_{in} = C_{out} = 2.2\mu F$, $T_A = -40^\circ C \sim +85^\circ C$, unless otherwise noted. Typical value are $T_A = 25^\circ C$, $V_{CC} = 3.6V$.

Symbol	Parameter	Condition	Min.	Typ.	Max.	Unit
Input Power Supply						
V_{CC}	Operation range		2.8		5.5	V
I_{CC}	Operating current	$2.8 \leq V_{CC} \leq 5.5$, $I_{SET} = 20mA$ charge pump disable		0.5	1	mA
I_{SHDN}	Shutdown current	$V_{EN/SET} = 0V$		0.5	3	μA
I_{DX}	I_{SINK} average current accuracy	$I_{SET} = 20mA$		20		mA
$I_{(D-Match)}$	Current matching	$I_{SET} = 20mA$		± 0.9		%
V_{TH}	Transition threshold at any I_{SINK} pin			210		mV
Charge Pump Section						
T_{SS}	Soft-start time	(Note 1)		33		μs
F_{CLK}	Clock frequency	(Note 1)		1		MHz
EN/SET						
$V_{EN(L)}$	Enable threshold low	$V_{CC} = 2.8V$			0.4	V
$V_{EN(H)}$	Enable threshold high	$V_{CC} = 5.5V$	1.4			V
$T_{EN/SET LO}$	EN/SET low time		0.3		75	μs
$T_{EN/SET HI_MIN}$	Minimum EN/SET high time			50		ns
$T_{EN/SET HI_MAX}$	Maximum EN/SET high time				75	μs
T_{OFF}	EN/SET off timeout	(Note 1)	500			μs
T_{LAT}	EN/SET latch timeout	(Note 1)	500			μs
$R_{EN/SET DOWN}$	EN/SET pull down resistor			500		k Ω

Note1: Guaranteed by design.

Typical Performance Characteristic

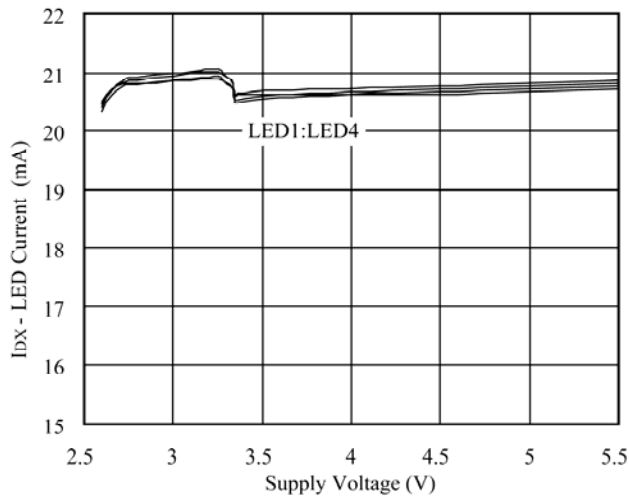

Figure 5 LED Current vs. Supply Voltage (SN3228A)

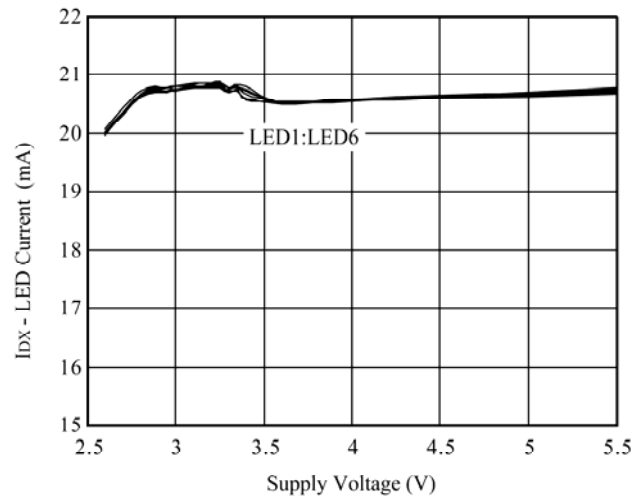

Figure 6 LED Current vs. Supply Voltage (SN3228B)

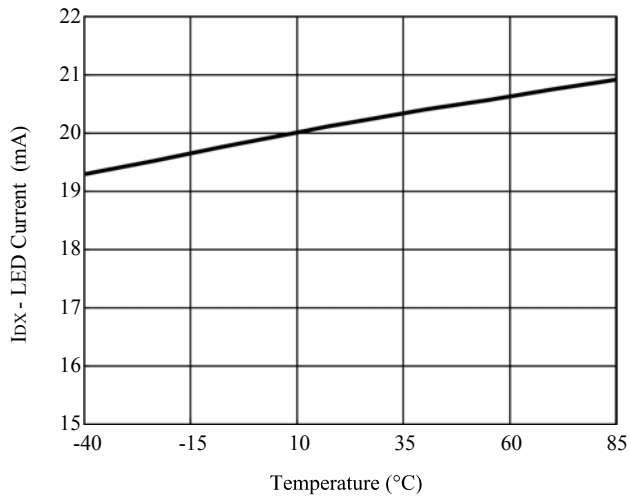

Figure 7 LED Current vs. Temperature

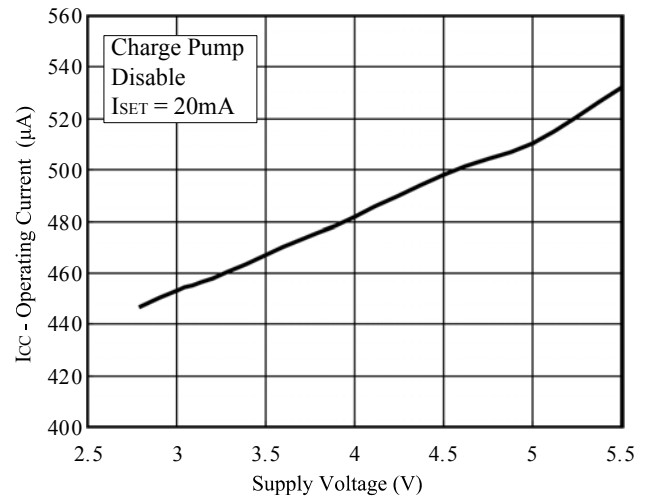

Figure 8 I_{CC} vs. Supply Voltage

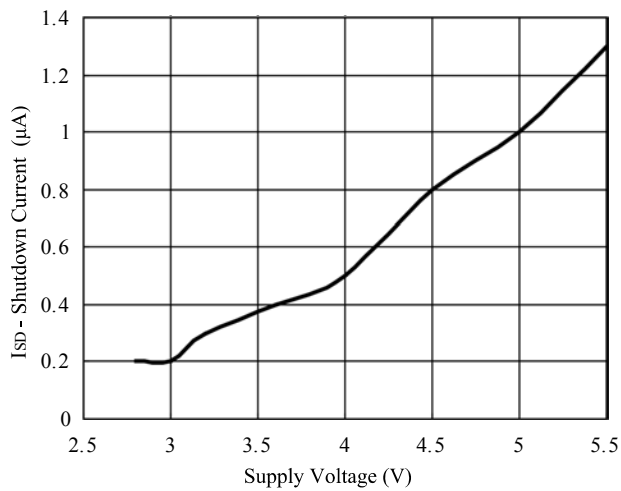

Figure 9 I_{SD} vs. Supply Voltage

Application information

General Description

The SN3228A(SN3228B) charge pump drives up to four(six) white LEDs with regulated constant current for uniform intensity. It achieves 20mA output drive capability over the 1-cell lithium-battery input voltage range. Fixed-frequency switching of 1MHz allows for tiny external components, and the regulation scheme is optimized to ensure low EMI and low input ripple.

Since the output current sources of the SN3228A(SN3228B) are programmable, no PWM (pulse width modulation) or additional control circuitry is needed to control LED brightness. This feature greatly reduces the burden on a microcontroller or system IC to manage LED or display brightness, allowing the user to "set it and forget it." With its high-speed serial interface (1MHz data rate), the output current of the SN3228A(SN3228B) can be changed successively to brighten or dim LEDs, in smooth transitions (e.g., to fade-out) or in abrupt steps, giving the user complete programmability and real-time control of LED brightness.

Constant Current Output Level Setting

The constant current source levels for D5/D3 to D0 are set via the serial interface according to a logarithmic scale. For the whole 14 codes, each code is approximately 1.5dB lower than the previous code. In this manner, LED brightness appears linear with each increasing code count. Because the outputs D5/D3 to D0 are true independent constant current sources, the voltage observed on any single given output will be determined by the actual forward voltage (V_F) for the LED being driven.

Functional Description

The four (six) constant current source outputs (D5/D3 to D0) can drive four (six) individual LEDs with a maximum current of 20mA each. The PCC wire serial interface enables the SN3228A(SN3228B) and sets the current source magnitudes.

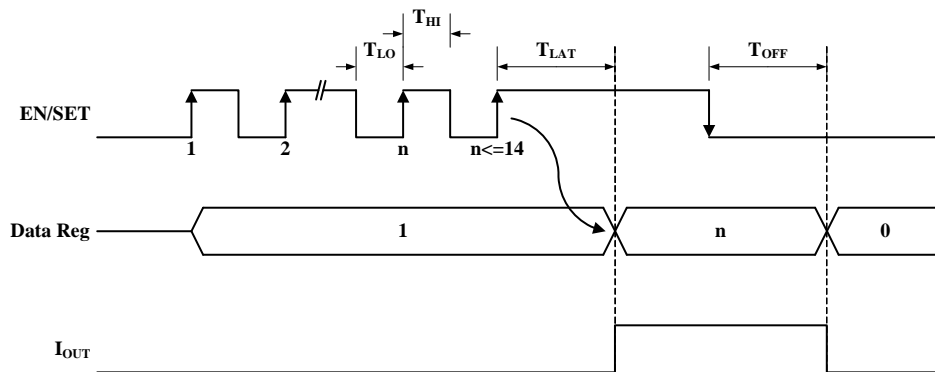

Figure 10 PCC wire Serial Interface Timing

PCC Wire Serial Interface

The current level magnitude is controlled by Pulse Count Control (PCC wire) serial interface. The interface records rising edges of the EN/SET pin and decodes them into 14 different states. The 14 current level settings available are indicated in Table 1.

The PCC wire serial interface has flexible timing. Data can be clocked-in at speeds from 15 kHz to above 1MHz. After data is submitted, EN/SET is held high to latch the data. Once EN/SET has been held in the logic high state for time T_{LAT} , the programmed current becomes active and the internal data register is reset to zero. For subsequent current level programming, the number of rising edges corresponding to the desired code must be entered on the EN/SET pin.

Table 1 Current Level Setting

Data	Output(mA/Ch)	Data	Output(mA/Ch)
1	20.0	8	6.0
2	17.0	9	5.0
3	14.0	10	4.2
4	12.0	11	3.6
5	10.0	12	3
6	8.6	13	2.4
7	7.0	14	1.8

PCC Wire Serial Interface Timing

Figure 10 shows the timing of PPC wire. When EN/SET is held low for an amount of time greater than T_{OFF} , the SN3228A(SN3228B) enters into shutdown mode and draws less than $1\mu\text{A}$ from V_{CC} . The internal data register is reset to zero during shutdown.

Drive Fewer LEDs

When driving fewer than four (SN3228A) (six for SN3228B) LEDs, keep the unused pin to GND or floating, but D0 must be connected.

Device Switching Noise Performance

The SN3228A(SN3228B) operates at a fixed frequency of approximately 1MHz to control noise and limit harmonics that can interfere with the RF operation of cellular telephone handsets or other communication devices. Back-injected noise appearing on the input pin of the charge pump is 60mV peak-to-peak, typically ten times less than inductor-based DC/DC boost converter white LED backlight solutions. The SN3228A(SN3228B) soft-start feature prevents noise transient effects associated with inrush currents during start-up of the charge pump circuit.

Thermal Protection

The SN3228A(SN3228B) has a thermal protection circuit that will shut down the chip if the die temperature rises above the thermal limit.

Although the SN3228A(SN3228B) is designed for driving white LEDs, the device also can be used to drive most types of LEDs with forward voltage specifications ranging from 1.8V to 4.7V. LED applications may include main and sub-LCD display backlighting, camera photo-flash applications, color (RGB) LEDs, infrared (IR) diodes for remotes, and other loads benefiting from a controlled output current generated from a varying input voltage. Since the D5/D3 to D0 output current sources are matched with negligible voltage dependence, the LED brightness will be matched regardless of the specific LED forward voltage (V_F) levels. In some instances (e.g., in high luminous output applications such as photo flash), it may be necessary to drive high- V_F type LEDs. The low dropout current sources in the SN3228A(SN3228B) make it capable of driving LEDs with forward voltages as high as 4.7V at full current from an input supply of 2.8V to 5.5V. Outputs can be paralleled to drive high-current LEDs without complication

Capacitor Selection

Careful selection of the external capacitors (C_{in} and C_{out}) is important because they will affect turn-on time, output ripple, and transient performance. Optimum performance will be obtained when low equivalent series resistance (ESR) ceramic capacitors are used. In general, low ESR may be defined as less than $100\text{m}\Omega$. A value of $2.2\mu\text{F}$ for all three capacitors is a good starting point when choosing capacitors. If the LED current sources are programmed only for light current levels, then the capacitor size may be decreased.

Capacitor Characteristics

Ceramic composition capacitors are highly recommended over all other types of capacitors for use with the SN3228A(SN3228B). Ceramic capacitors offer many advantages over their tantalum and aluminum electrolytic counterparts. A ceramic capacitor typically has very low ESR, is lowest cost, has a smaller PCB footprint, and is non-polarized. Low ESR ceramic capacitors help to maximize charge pump transient response. Since ceramic capacitors are non-polarized, they are not prone to incorrect connection damage.

Equivalent Series Resistance

ESR is an important characteristic to consider when selecting a capacitor. ESR is a resistance internal to a capacitor that is caused by the leads, internal connections, size or area, material composition, and ambient temperature. Capacitor ESR is typically measured in milliohms for ceramic capacitors and can range to more than several ohms for tantalum or aluminum electrolytic capacitors.

Ceramic Capacitor Materials

Ceramic capacitors less than $0.1\mu\text{F}$ are typically made from NPO or C0G materials. NPO and C0G materials generally have tight tolerance and are very stable over temperature. Larger capacitor values are usually composed of X7R, X5R, Z5U, or Y5V dielectric materials. Large ceramic capacitors (i.e., greater than $2.2\mu\text{F}$) are often available in low-cost Y5V and Z5U dielectrics.

Capacitor area is another contributor to ESR. Capacitors that are physically large will have a lower ESR when compared to an equivalent material smaller capacitor. These larger devices can improve circuit transient response when compared to an equal value capacitor in a smaller package size.

Classification Reflow Profiles

Profile Feature	Pb-Free Assembly
Preheat & Soak	
Temperature min (T _{smin})	150°C
Temperature max (T _{smax})	200°C
Time (T _{smin} to T _{smax}) (t _s)	60-120 seconds
Average ramp-up rate (T _{smax} to T _p)	3°C/second max.
Liquidous temperature (T _L)	217°C
Time at liquidous (t _L)	60-150 seconds
Peak package body temperature (T _p)*	Max 260°C
Time (t _p)** within 5°C of the specified classification temperature (T _c)	Max 30 seconds
Average ramp-down rate (T _p to T _{smax})	6°C/second max.
Time 25°C to peak	8 minutes max.

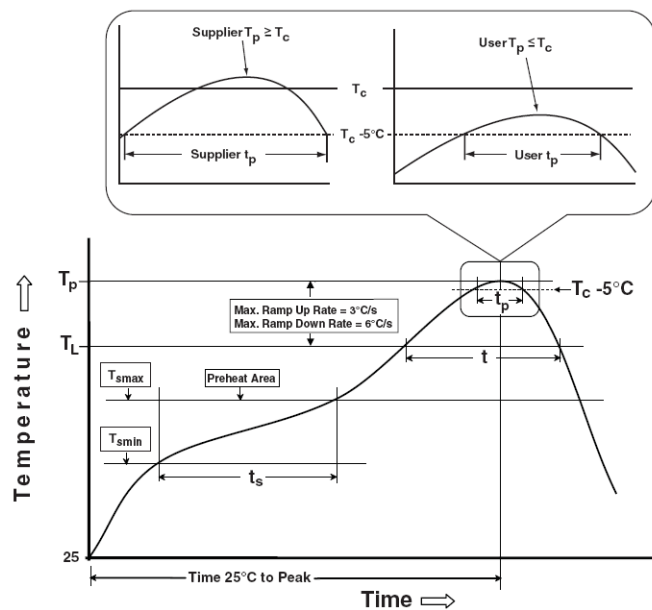
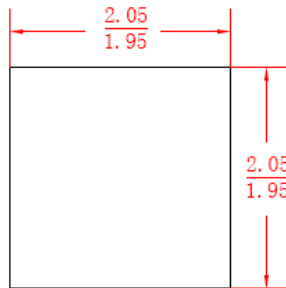

Figure 11 Classification profile

Package Information

UTQFN-12



TOP VIEW

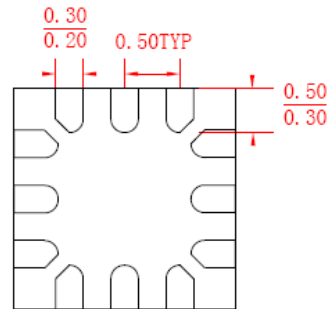

BOTTOM VIEW

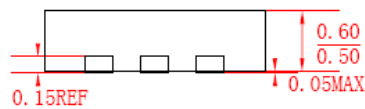

SIDE VIEW

Note: All dimensions in millimeters unless otherwise stated.

IMPORTANT NOTICE

SI-EN Technology cannot assume responsibility for use of any circuitry other than circuitry entirely embodied in a SI-EN Technology product. SI-EN Technology reserves the right to make corrections, modifications, enhancements, improvements, and other changes to its specifications, products and services at any time and to discontinue any product or service without notice. Customers should obtain the latest relevant information before placing orders and should verify that such information is current and complete.