

CVM57L Series Dual Frequency VCXO

Dimensions are in millimeters. Dot indicates pin one location.

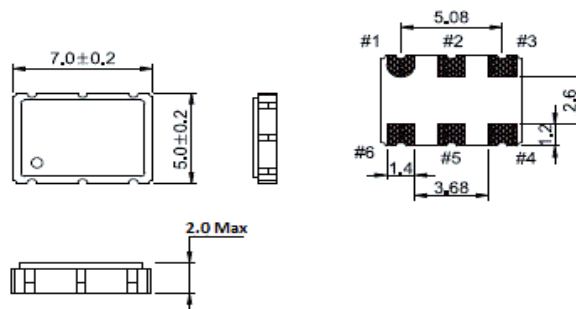

Land Pattern

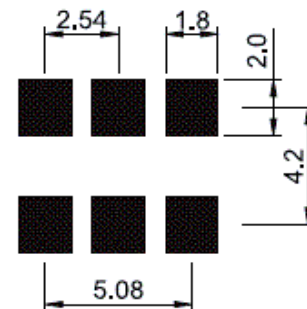

5x7 Ceramic 6 Pad
RoHS Compliant
LVDS Output
2.5V or 3.3V
50.000MHz to
1.5.000GHz
Up To Two Frequencies

Electrical Specifications

Frequency Range		50.000MHz to 1.500GHz
Operating Temperature Range		0°C to 70°C, -20° to 70°C or -40° to 85°C
Storage Temperature Range		-55°C to 125°C
Supply Voltage	VDD ±5%	2.5 Or 3.3
Waveform		LVDS
Supply Current		23mA Typical
Load		100Ω
Frequency Tolerance / Stability	Inclusive of Operating Temp Range, Supply Voltage and Load	10 ,20, 25, 50 Or 100ppm
Duty Cycle	50% of Waveform	50 ± 5%
Rise Fall Time		350 pSecond Max
Period Jitter (RMS)		<2.5pSecond Max
Phase Jitter	12KHz to 20MHz	<1.0pSecond Typical
Startup Time		10mSeconds Max
Vol	2.50 VDC 3.30 VDC	1.1V Typical 0.9V Typical
Voh	2.50 VDC 3.30 VDC	1.5V Typical 1.6V Typical
Differential Voltage	2.50 VDC 3.30 VDC	.400V Typical .450V Typical
Control Voltage	2.50 VDC 3.30 VDC	1.25VDC ±1.00VDC 1.65VDC ± 1.50VDC
Pullability		±100ppm
Linearity		10ppm
Tri-State	VIH≥70% of VDD VIH≤30% of VDD	Enables Output Disables Output: High Impedance
Tristate Current Consumption	Disabled	16mA
Aging		±5.0ppm First Year

Part Marking	
Line #1	CVM57L
Line #2	XX.XXX M XX.XXX = Frequency (5 Digits Max + Decimal) M = Frequency Unit Of Measure (MHz)
Line #3	XX YY ZZ XX = Crescent Manufacturing Identifier YY = Last Two Digits of Year ZZ = Week of Year

Pad Connections	
Pad 1	VC
Pad 2*	Tristate or Frequency Select
Pad 3	Ground
Pad 4	Output
Pad 5	Complimentary Output
Pad 6	Supply Voltage

*No Tristate With Dual Frequency

Single Frequency Reference Table		
Pin 1	Pin 2	Corresponding Frequency
VC	Tristate	Frequency 1

Dual Frequency Reference Table		
Pin 1	Pin 2	Corresponding Frequency
VC	Logic "0"	Frequency 1
VC	Logic "1"	Frequency 2

Phase Noise	
Offset Frequency	70.000MHz
100Hz	-88dBc/Hz
1KHz	-115dBc/Hz
10KHz	-120dBc/Hz
100KHz	-125dBc/Hz
1MHz	-130dBc/Hz
10MHz	-145dBc/Hz

Mechanical / Environmental	
Shock	MIL-STD-883, Method 2002 Cond B
Solvent Resistance	MIL-STD-202, Method 215
Solderability	MIL-STD-883, Method 2003
MSL	Level 1 Per IPC/JEDEC J-STD 20
Gross Leak Test	MIL-STD-883, Method 1014, Cond C
Fine Leak Test	MIL-STD-883, Method 1014, Cond A2
Vibration	MIL-STD-883, Method 2007, Cond A

Part Numbering Guide

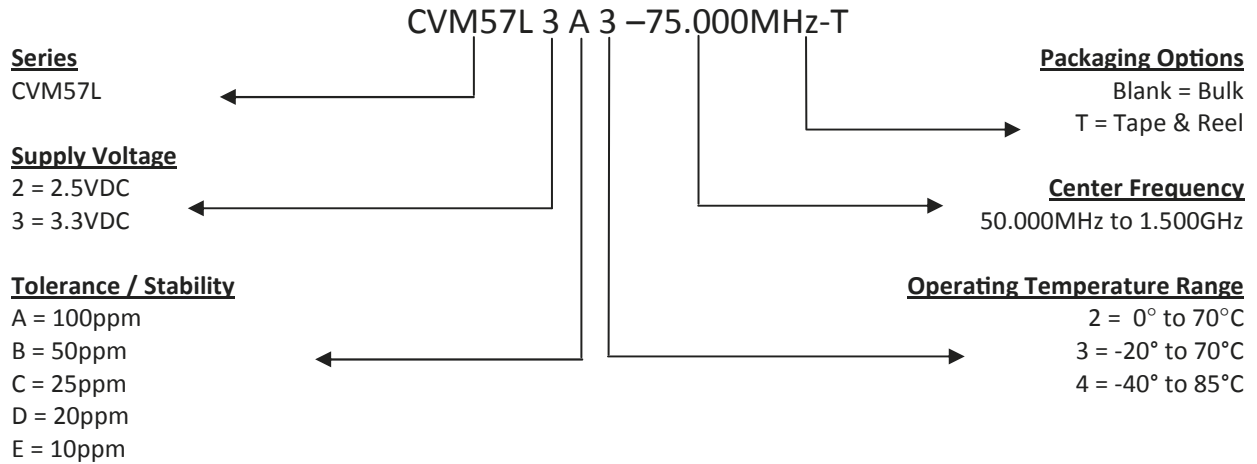

Test Set Up

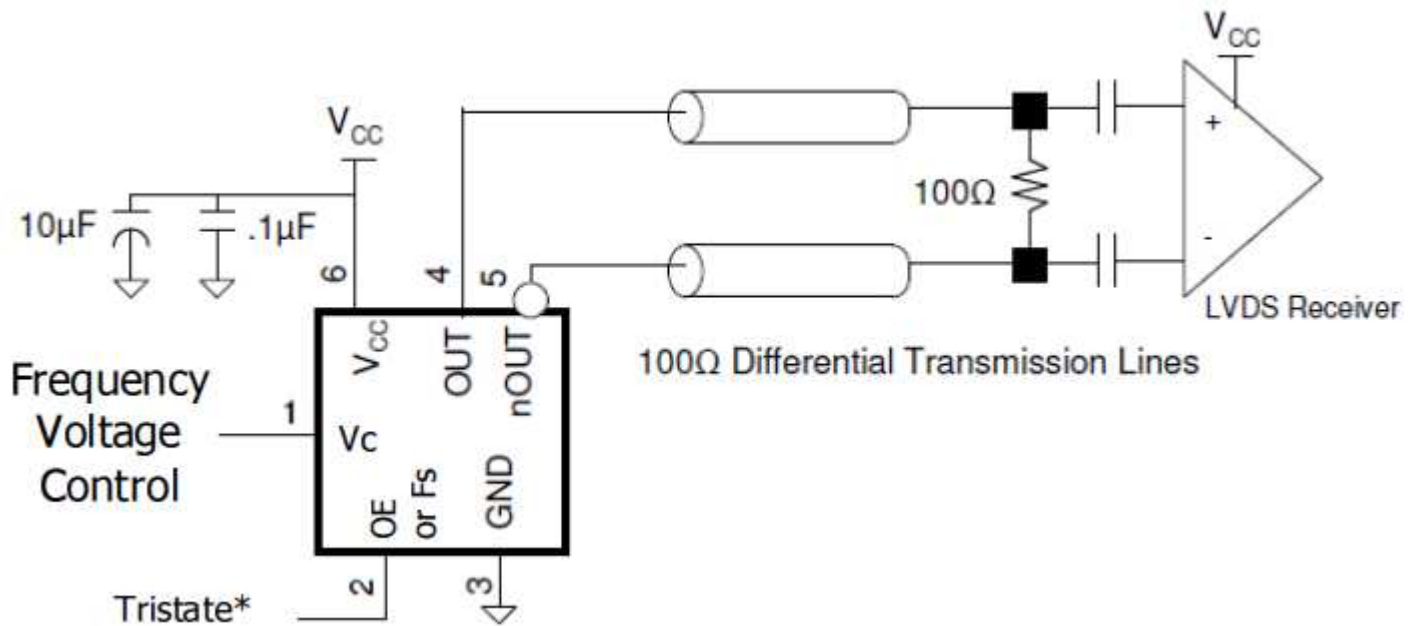

*Pin 2 is Frequency Select With Dual Frequency