

CV8 Series VCXO

12.7x12.7mm
Metal Can
RoHS Compliant
HCMOS / TTL
3.3 or 5.0VDC
1.000 to 300.000MHz
VC on Pin 1

Mechanical Dimensions

Dimensions are in millimeters. Dot indicates pin one location.

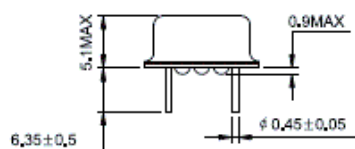
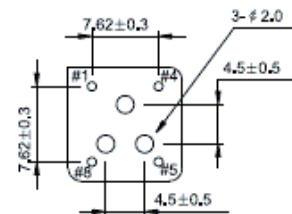
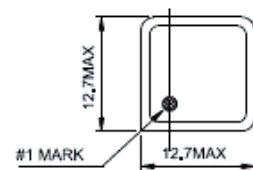

PIN CONNECTION

#1 V.C
#4 GND
#5 OUTPUT
#8 VDD

Electrical Specifications

Frequency Range	1.000MHz to 300.000MHz	
Stability	10ppm, 20ppm, 25ppm, 50ppm, or 100ppm*	
Operating Temperature Range	0°C to 70°C or -40°C to 85°C*	
Storage Temperature	-55°C to 125°C	
Output	HCMOS/TTL Output	
Supply Voltage	5.0V _{DC} ±5% Or 3.3V _{DC} ± 5%	
Linearity	±20%, ±15%, ±10% or ±5%	
Load Drive	10TTL Load Or 15pF HCMOS Load	
Frequency Deviation / Pin 1 Control Voltage	See Part Numbering Guide	
Duty Cycle	50 ± 5%	
Output Voltage Logic High (V _{OH})	With TTL Load With HCMOS Load	2.4V _{DC} Min. 90% of V _{DD} Min.
Output Voltage Logic Low (V _{OL})	With TTL Load With HCMOS Load	0.4V _{DC} Min. 10% of V _{DD} Max
Rise / Fall Time	5nS Max	
Start Time	10mS Max	
Jitter Period: pk-pk Period: One Sigma	100pS Max 25pS Max	
Input Current	1.000 to 25.000MHz 25.001 to 50.000MHz 50.001 to 80.000MHz 80.001 to 155.520MHz	20mA Max 30mA Max 40mA Max 50mA Max

Part Numbering Guide

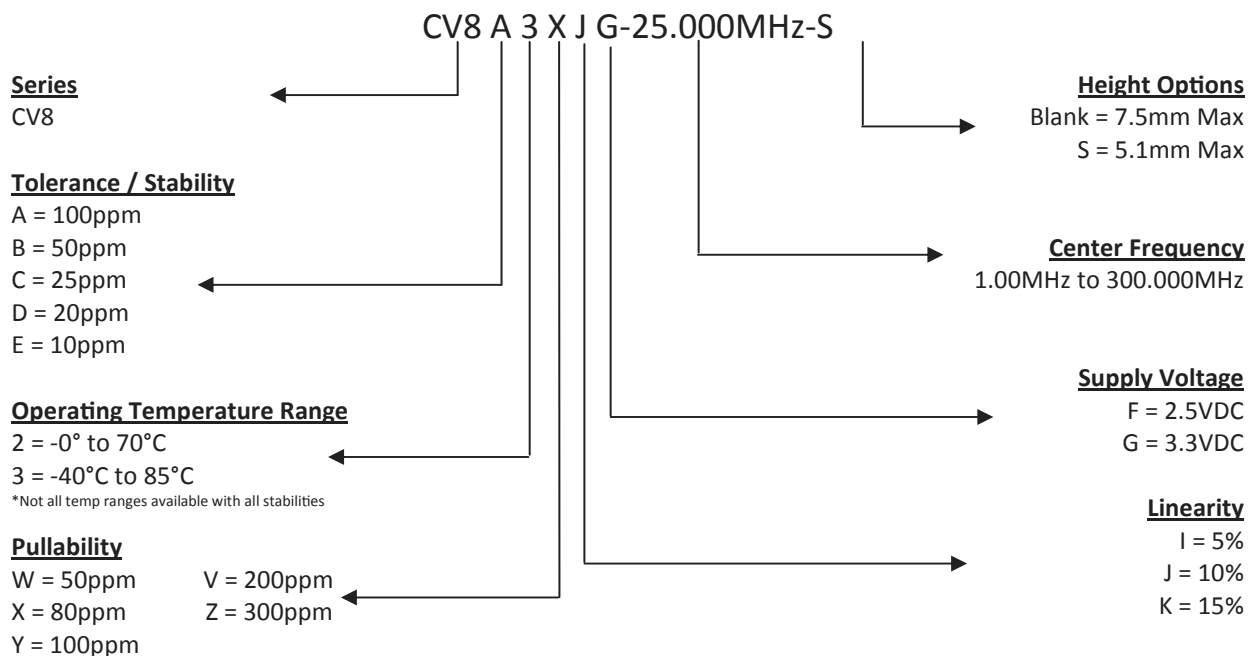

Part Marking Guide

Line #1	CFP CV8
Line #2	XX.XXX M XX.XXX = Frequency (5 Digits Max + Decimal) M = Frequency Unit Of Measure (MHz)
Line #3	XX YY ZZ XX = Crescent Manufacturing Identifier YY = Last Two Digits of Year ZZ = Week of Year

Environmental & Mechanical

Shock	MIL-STD-883, Method 2002, Condition B
Solderability	MIL-STD-883, Method 2003
Vibration	MIL-STD-883, Method 2007, Condition A
Reflow Solderability	260°C For 10 Seconds
Fine Leak Test	MIL-STD-883, Method 1014, Condition A
Gross Leak Test	MIL-STD-88s, Method 1014, Condition C