

CXM57L Series Multiple Frequency Oscillator

Dimensions are in millimeters. Dot indicates pin one location.

Land Pattern

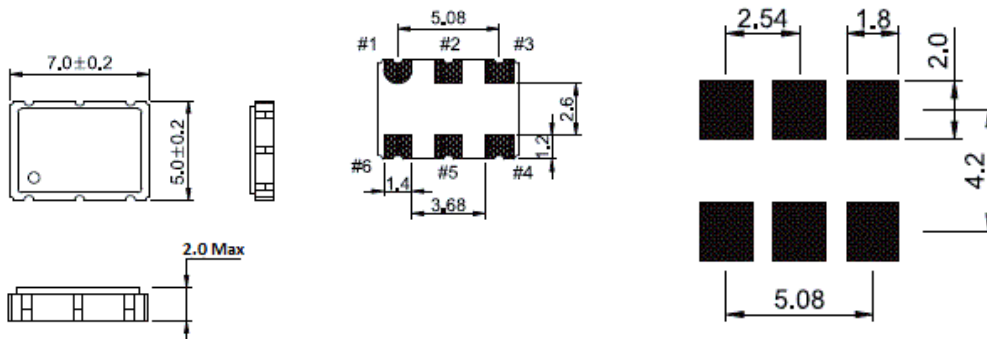

Electrical Specifications

Frequency Range		50.000MHz to 1.500GHz
Operating Temperature Range		0°C to 70°C, -20° to 70°C or -40° to 85°C
Storage Temperature Range		-55°C to 125°C
Supply Voltage	VDD ±5%	2.5 Or 3.3
Waveform		LVDS
Supply Current		23mA Typical
Load		100Ω
Frequency Tolerance / Stability	Inclusive of Operating Temp Range, Supply Voltage and Load	10 ,20, 25, 50 Or 100ppm
Duty Cycle	50% of Waveform	50 ± 5%
Rise Fall Time		350 pSecond Max
Period Jitter (RMS)		<2.5pSecond Max
Phase Jitter	12KHz to 20MHz	<1.0pSecond Typical
Startup Time		10mSeconds Max
Vol	2.50 VDC 3.30 VDC	1.1V Typical 0.9V Typical
Voh	2.50 VDC 3.30 VDC	1.5V Typical 1.6V Typical
Tri-State	VIH≥70% of VDD VIH≤30% of VDD	Enables Output Disables Output: High Impedance
Tristate Current Consumption	Disabled	16mA
Aging		±5.0ppm First Year

Part Marking	
Line #1	CXM57L
Line #2	XX.XXX M XX.XXX = Frequency (5 Digits Max + Decimal) M = Frequency Unit Of Measure (MHz)
Line #3	XX YY ZZ XX = Crescent Manufacturing Identifier YY = Last Two Digits of Year ZZ = Week of Year

Pad Connections		Single Frequency
Pad 1	See Reference Table	Tristate or Frequency Select
Pad 2*	See Reference Table	No Connection
Pad 3	Ground	Ground
Pad 4	Output	Output
Pad 5	Complimentary Output	Complimentary Output
Pad 6	Supply Voltage	Supply Voltage

Dual Frequency Reference Table	
Pin 2	Corresponding Frequency
Ground	Frequency 1
Vdd	Frequency 2

Quad Frequency Reference Table		
Pin 1	Pin 2	Corresponding Frequency
Ground	Ground	Frequency 1
Ground	Vdd	Frequency 2
Vdd	Ground	Frequency 3
Vdd	Vdd	Frequency 4

Phase Noise	
Offset Frequency	160.000MHz Output
100Hz	-85dBc/Hz
1KHz	-100dBc/Hz
10KHz	-115dBc/Hz
100KHz	-118dBc/Hz
1MHz	-128dBc/Hz
10MHz	-145dBc/Hz

Mechanical / Environmental	
Shock	MIL-STD-883, Method 2002 Cond B
Solvent Resistance	MIL-STD-202, Method 215
Solderability	MIL-STD-883, Method 2003
MSL	Level 1 Per IPC/JEDEC J-STD 20
Gross Leak Test	MIL-STD-883, Method 1014, Cond C
Fine Leak Test	MIL-STD-883, Method 1014, Cond A2
Vibration	MIL-STD-883, Method 2007, Cond A

- * Tristate Option Available
- ** No Tristate With Quad Frequency
- *** External Bypass Capacitor Recommended

Part Numbering Guide

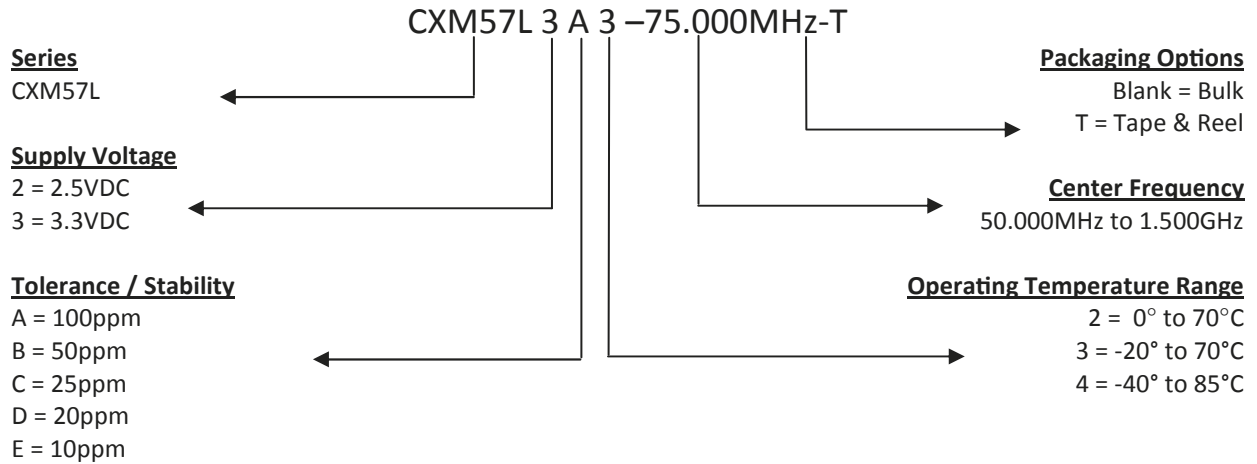

Test Set Up

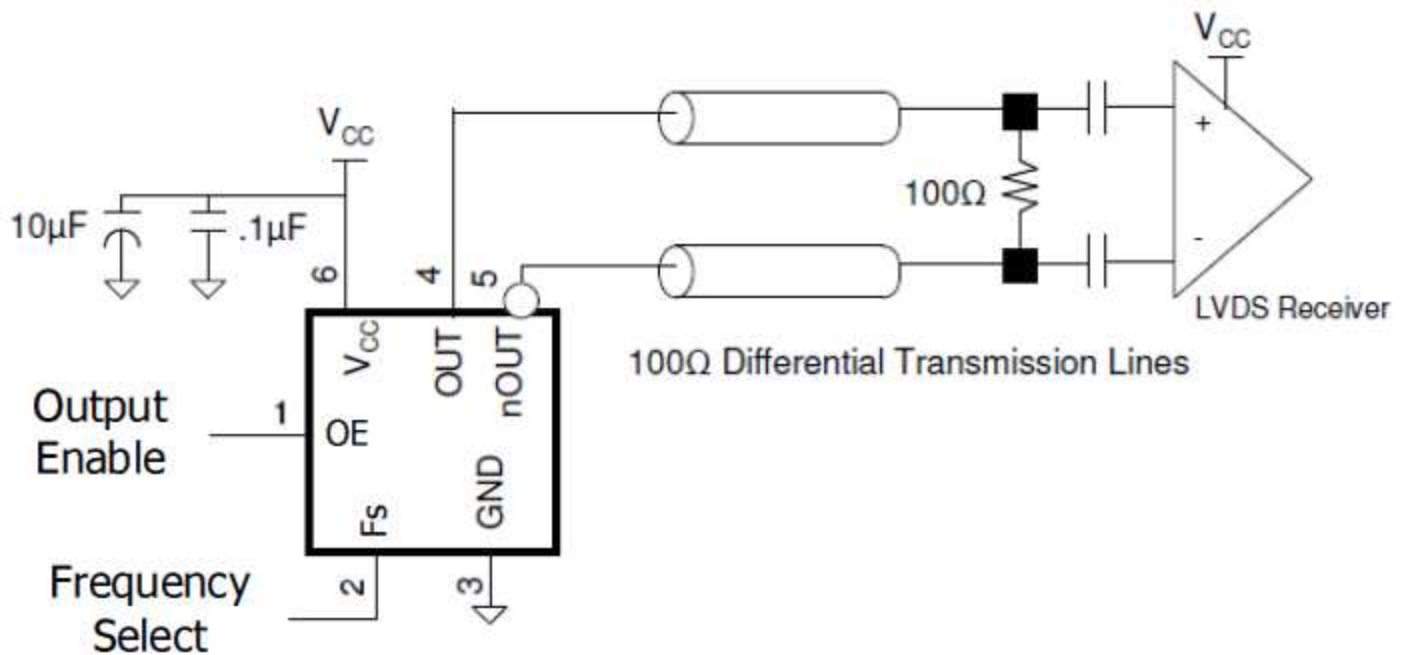

Pin 2 is Frequency Select With Dual Frequency