

3-Electrode Gas Tube Arrester

UN3E6-150MM

φ6×8.5

5KA×2

Dimension

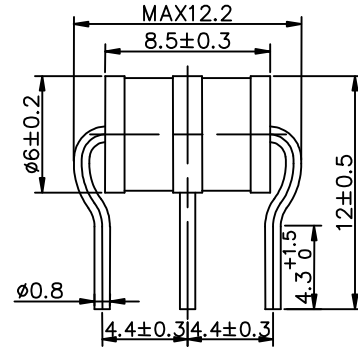

Unit:mm

Nickel-plated

Electrical Specifications			Applications	
DC Spark-over Voltage at 100V/S	150±20%	V	<ul style="list-style-type: none"> u Branch exchange(MDF) u Date/Single line protection u Station protection u Telephone / Fax / modem protection u Consumer electronics 	
Impulse Spark-over Voltage at 100V/μs at 1KV/μs	<500	V		
	<600	V		
Life:				Feature <ul style="list-style-type: none"> u Non-Radioactive u ROHS Compliant u LOW Capacitance u High insulation resistance u Fast response-time u Very small size
Impulse Discharge current 8/20μs (±5 times)	5×2	KA		
10/1000μs (300 times)	100	A		
AC Discharge current (1S,5times interval 3 minutes)	5×2	A		
Insulation resistance at DC 50V	>1000	MΩ		
Electrode Capacitance at 1MHz	<1.5	pF		
Arc Voltage at 1A	~25	V		
Glow Voltage at 1mA	~70	V		
Holdover Voltage at 100mA, <150mS	80	V		
Transverse delay time	< 0.2	μs		
Weight	~1.3	g		
Operation and storage Temperature	-40~+90	°C		
Marking, Black	UNION 150M-YY 150 -Nominal voltage M -10KA YY -Year of production			

Notes:

1. Terms in accordance with ITU-T K.12 and GB/T 9043-2008
2. At delivery AQL 0.65 level II , DIN ISO 2859
3. After life test:
 DC Spark-over Voltage at 100V/S :150±30%
 Impulse Spark-over Voltage at 1KV/μs<700V