



\* Standard

# SPECIFICATION [SWBF0B]

| SSC      |            |             | Customer    |
|----------|------------|-------------|-------------|
| Drawn by | Checked by | Approved by | Approved by |
| DH.LEE   | HS.LIM     | H.J.Hong    |             |
| 02/20    | 02/20      | 2013.02.21  |             |

Rev. 01

February, 2013

www.acrich.com



# Contents

|     |                                 |       |    |
|-----|---------------------------------|-------|----|
| 1.  | Description                     | ----- | 4  |
| 2.  | Absolute Maximum Ratings        | ----- | 5  |
| 3.  | Electro-Optical Characteristics | ----- | 5  |
| 4.  | Characteristic Diagram          | ----- | 6  |
| 5.  | Reliability Test                | ----- | 9  |
| 6.  | Color & Binning                 | ----- | 10 |
| 7.  | Outline Dimension               | ----- | 12 |
| 8.  | Material List                   | ----- | 13 |
| 9.  | Packing                         | ----- | 14 |
| 10. | Soldering                       | ----- | 16 |
| 11. | Precaution for use              | ----- | 17 |



# SWBF0B

## SWBF0B

### 1. Description

- 1-chip in one package
- SMT solderability
- Own patent reserved
- RoHS Compliant
- Low Thermal Resistance
- Pb-free Reflow Soldering application
- SWBF0B is very useful side view LED in back light unit application

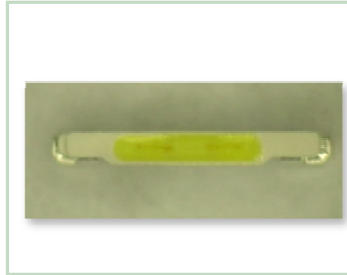

### Features

- 3.8 (W) X 1.0 (D) X 0.4 (T) mm
- Side View LED of Reflector type

### Applications

- Flat Backlighting (LCD, Display)
- Mobile Phone, Camera, PDA, Notebook
- Coupling into Light Guide Panel
- AV systems

## 2. Absolute maximum ratings

( $T_a = 25^\circ\text{C}$ )

| Parameter             | Symbol        | Value      | Unit             |
|-----------------------|---------------|------------|------------------|
| Power Dissipation     | $P_d^{*1}$    | 85         | mW               |
| DC Forward Current    | $I_F$         | 25         | mA               |
| Peak Forward Current  | $I_{FM}^{*2}$ | 80         | mA               |
| Reverse Voltage       | $V_R$         | 5          | V                |
| Operating Temperature | $T_{opr}$     | -30 ~ +85  | $^\circ\text{C}$ |
| Storage Temperature   | $T_{stg}$     | -40 ~ +100 | $^\circ\text{C}$ |
| Junction Temperature  | $T_{j\ max}$  | 100        | $^\circ\text{C}$ |

\*1 Care is to be taken that power dissipation does not exceed the absolute maximum rating of the product.

\*2  $I_{FM}$  was measured at  $T_w \leq 0.1\text{msec}$  of pulse width and  $D \leq 1/10$  of duty ratio.

## 3. Electro-Optical characteristics

( $T_a = 25^\circ\text{C}$ )

| Parameter                        |           | Symbol          | Condition           | Min  | Typ | Max  | Unit          |
|----------------------------------|-----------|-----------------|---------------------|------|-----|------|---------------|
| Forward Voltage                  | Rank Z28  | $V_F$           | $I_F = 20\text{mA}$ | 2.8  | -   | 3.0  | V             |
|                                  | Rank Z30  |                 |                     | 3.0  | -   | 3.2  |               |
|                                  | Rank Z32  |                 |                     | 3.2  | -   | 3.4  |               |
|                                  | Rank z30  |                 |                     | 3.0  | -   | 3.4  |               |
| Reverse Current                  |           | $I_R$           | $V_R = 5\text{V}$   | -    | -   | 50   | $\mu\text{A}$ |
| Luminous Intensity* <sup>1</sup> | Rank S15H | $I_V$           | $I_F = 20\text{mA}$ | 1500 | -   | 1600 | mcd           |
|                                  | Rank S16H |                 |                     | 1600 | -   | 1700 |               |
|                                  | Rank S17H |                 |                     | 1700 | -   | 1800 |               |
|                                  | Rank S18H |                 |                     | 1800 | -   | 1900 |               |
|                                  | Rank S19H |                 |                     | 1900 | -   | 2000 |               |
|                                  | Rank S20H |                 |                     | 2000 | -   | 2100 |               |
|                                  | Rank S21H |                 |                     | 2100 | -   | 2200 |               |
| Viewing Angle * <sup>2</sup>     |           | $2\theta_{1/2}$ | $I_F = 20\text{mA}$ | 120  |     |      | deg.          |

\*<sup>1</sup> Luminous intensity  $I_V$  is measured at the peak of the spatial pattern which may not be aligned with the mechanical axis of the LED package. Luminous Intensity Measurement allowance is  $\pm 10\%$ .

\*<sup>2</sup>  $\theta_{1/2}$  is the off-axis where the luminous intensity is 1/2 of the peak intensity.

\* Tolerance of measurements of the Color Coordinates is  $\pm 0.007$

\* Tolerance of measurements of the Forward Voltage is  $\pm 0.1\text{V}$

\* The preliminary color coordinate can be changed without notice

\* Note : All products confirm to the listed minimum and maximum specifications for electric and optical characteristics, when operated at 20mA within the maximum ratings shown above.

All measurements were made under the standardized environment of Seoul Semiconductor.

Rev. 01

February, 2013

www.acrich.com

### 4. Characteristic Diagram

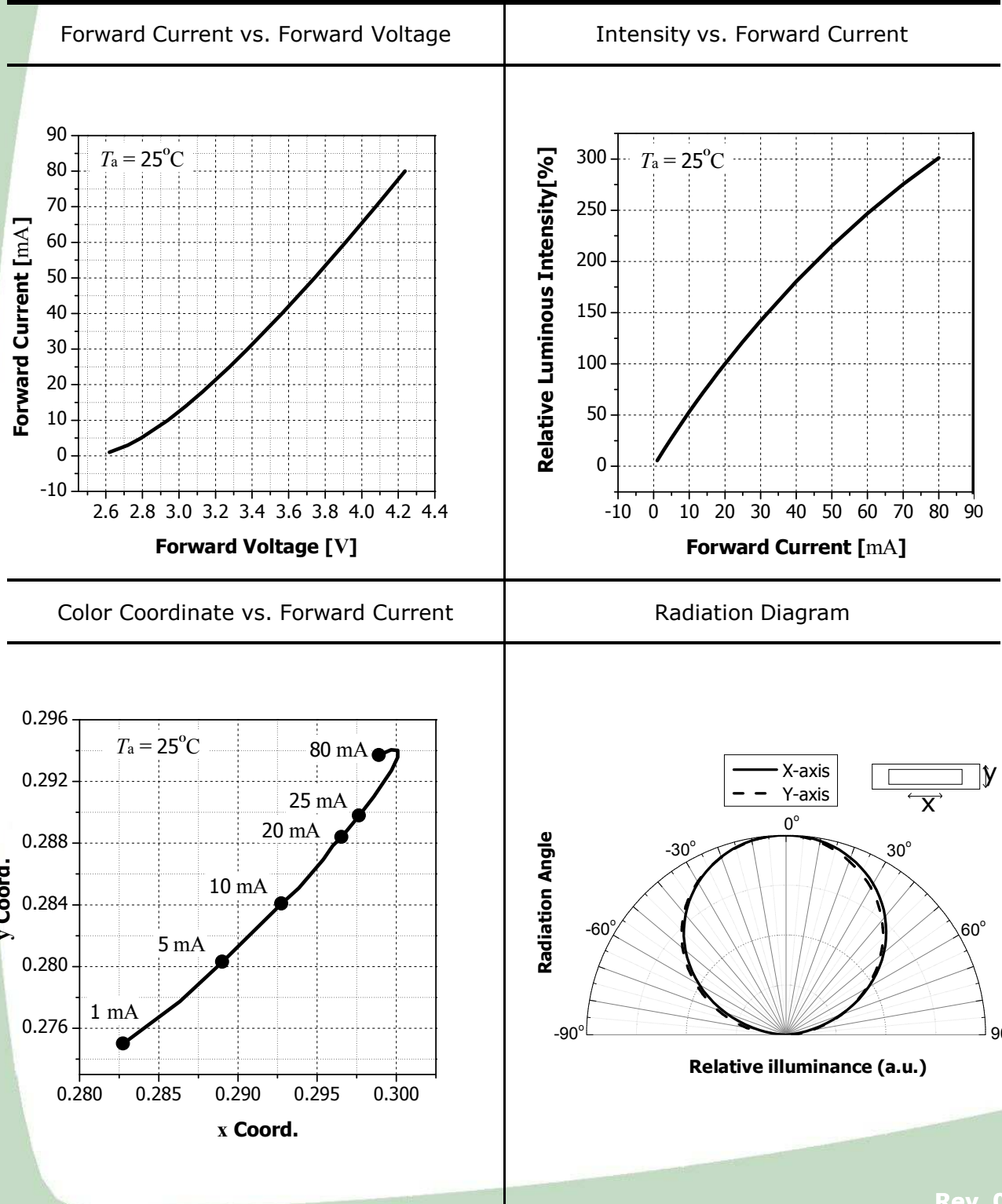

Rev. 01

February, 2013

www.acrich.com

Forward Voltage vs. Ambient Temperature

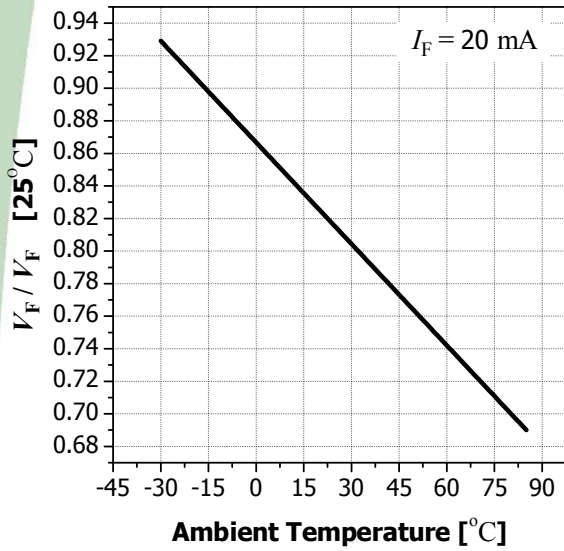

Relative Luminosity vs. Ambient Temperature

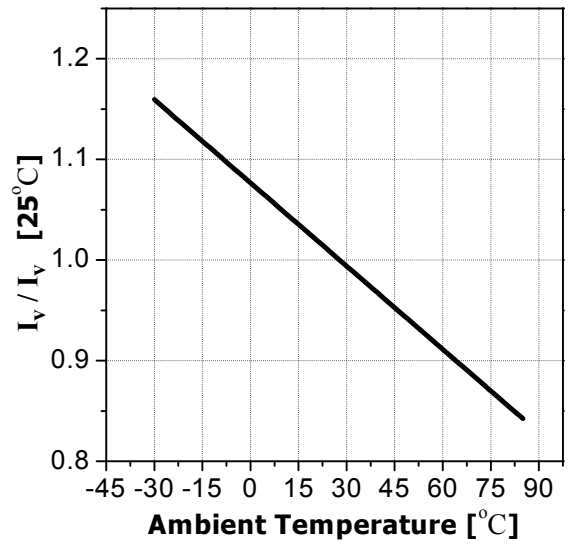

Color Coordinate vs. Ambient Temperature

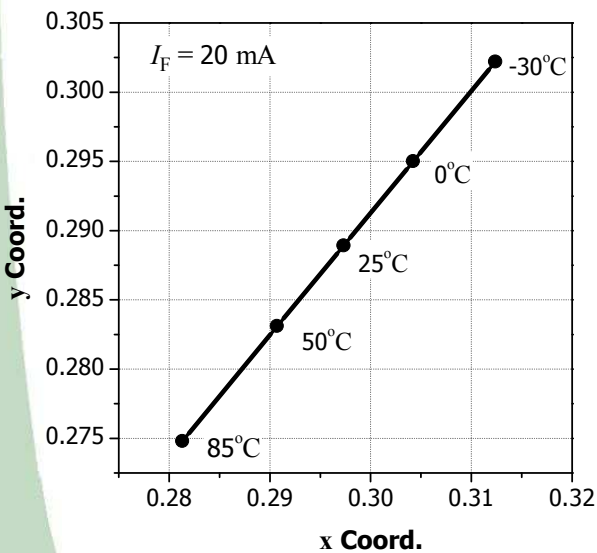

Spectrum

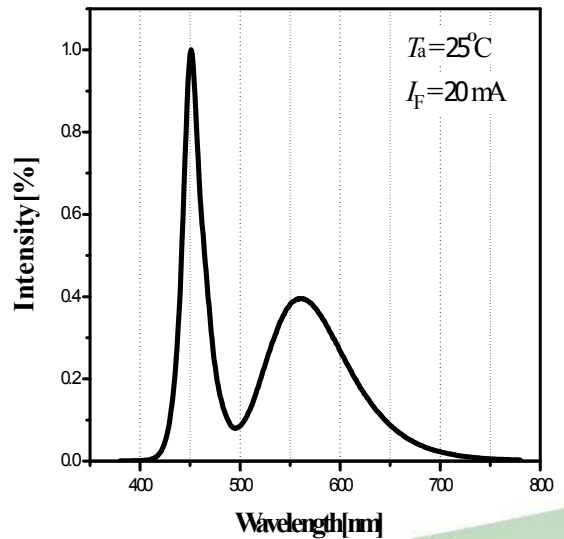

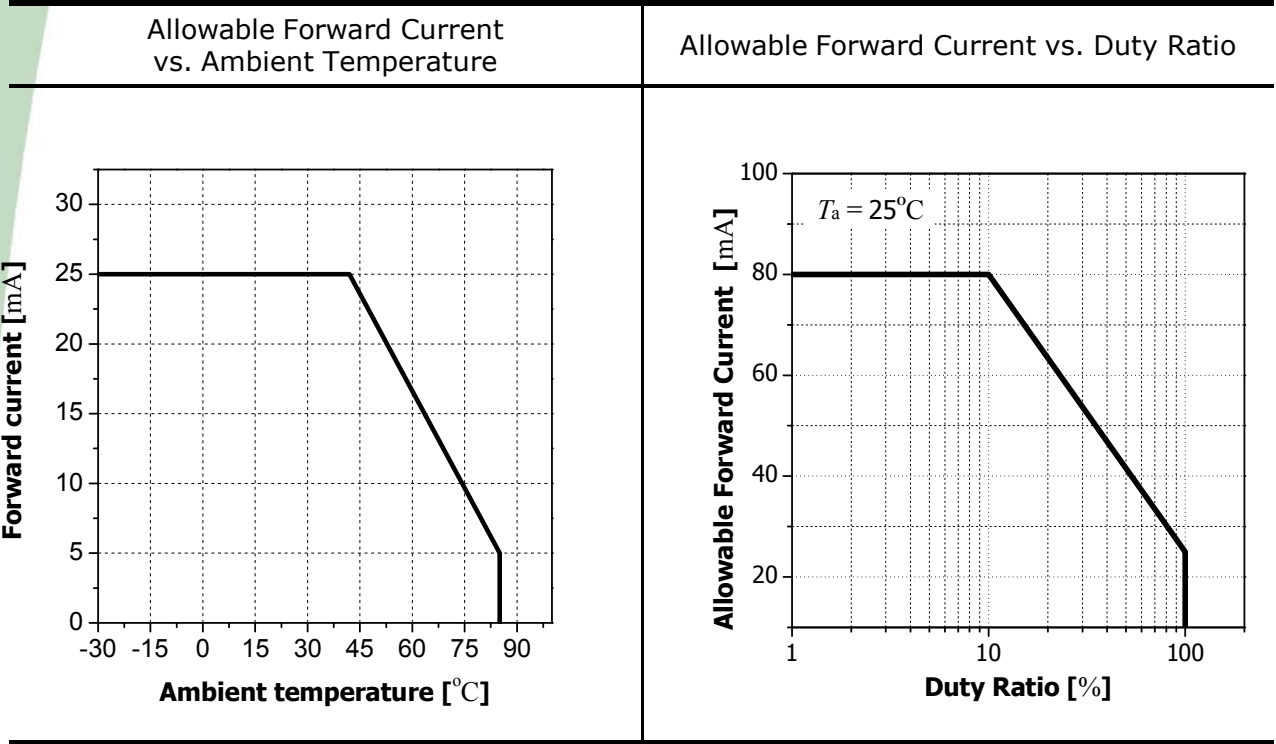

## 5. Reliability Test

### \* TEST ITEMS AND RESULTS

| Item                         | Reference             | Test Condition  | Duration / Cycle | Number of Damage |
|------------------------------|-----------------------|---|------------------|------------------|
| Life Test                    | -                     | $T_a = 25^\circ\text{C}, I_F = 20\text{mA}$   | 1,000 Hours      | 0/20             |
| High Temperature Life Test   | -                     | $T_a = 85^\circ\text{C}, I_F = 5\text{mA}$  | 1,000 Hours      | 0/20             |
| Low Temperature Life Test    | -                     | $T_a = -30^\circ\text{C}, I_F = 20\text{mA}$  | 1,000 Hours      | 0/20             |
| High Humidity Heat Life Test | JEITA ED-4701 100 102 | $T_a = 60^\circ\text{C}, \text{RH} = 90\%, I_F = 20\text{mA}$   | 500 Hours        | 0/20             |
| High Temperature Storage     | JEITA ED-4701 200 201 | $T_a = 100^\circ\text{C}$   | 1,000 Hours      | 0/20             |
| Low Temperature Storage      | JEITA ED-4701 200 202 | $T_a = -40^\circ\text{C}$   | 1,000 Hours      | 0/20             |
| Temperature Cycle            | JEITA ED-4701 100 105 | $-40^\circ\text{C} \sim 25^\circ\text{C} \sim 100^\circ\text{C} \sim 25^\circ\text{C}$<br>(30min) (5min) (30min) (5min) | 100 cycle        | 0/50             |

### \* Criteria for Judging the Damage

| Item               | Symbol | Condition           | Criteria for Judgement |                 |
|--------------------|--------|---------------------|------------------------|-----------------|
|                    |        |                     | MIN                    | MAX             |
| Forward Voltage    | $V_F$  | $I_F = 20\text{mA}$ | -                      | I.V. *1 × 1.2   |
| Reverse Current    | $I_R$  | $V_R = 5\text{V}$   | -                      | U.S.L. *2 × 2.0 |
| Luminous Intensity | $I_V$  | $I_F = 20\text{mA}$ | I.V. × 0.7             | -               |

Note : \*1 I.V. : Initial Value

\*2 U.S.L. : Upper Standard Level

Rev. 01

February, 2013

www.acrich.com

## 6. Color & Binning

\* CIE Chromaticity Diagram

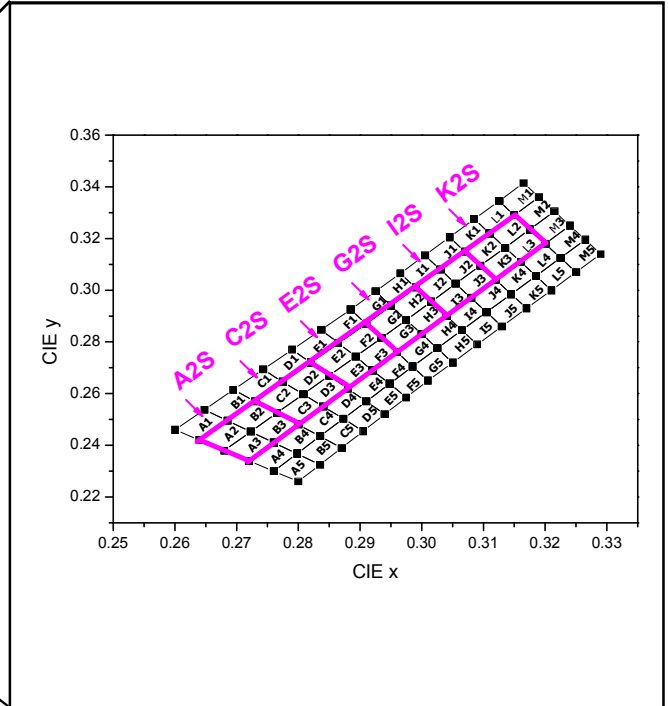
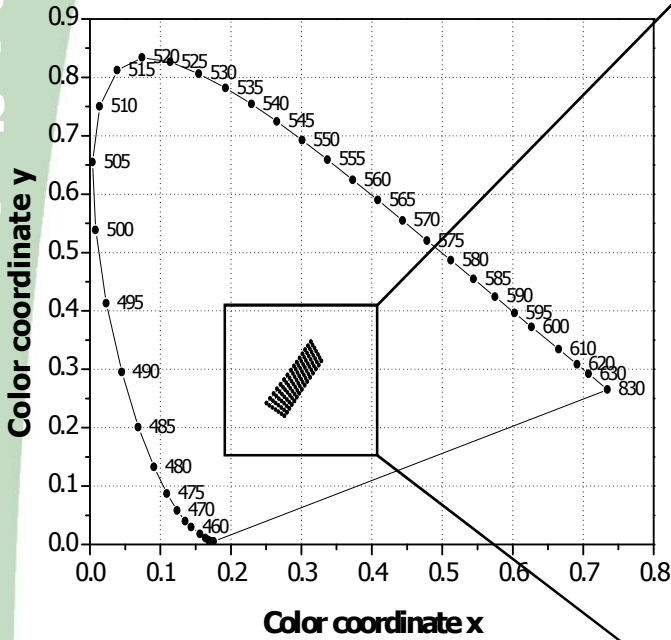

\* Color Rank

| A2S    |        | C2S    |        | E2S    |        |
|--------|--------|--------|--------|--------|--------|
| x      | y      | x      | y      | x      | y      |
| 0.2640 | 0.2420 | 0.2730 | 0.2570 | 0.2820 | 0.2720 |
| 0.2720 | 0.2340 | 0.2800 | 0.2480 | 0.2880 | 0.2620 |
| 0.2800 | 0.2480 | 0.2880 | 0.2620 | 0.2960 | 0.2760 |
| 0.2730 | 0.2570 | 0.2820 | 0.2720 | 0.2910 | 0.2870 |

| G2S    |        | I2S    |        | K2S    |        |
|--------|--------|--------|--------|--------|--------|
| x      | y      | x      | y      | x      | y      |
| 0.2910 | 0.2870 | 0.2990 | 0.3010 | 0.3070 | 0.3150 |
| 0.2960 | 0.2760 | 0.3040 | 0.2900 | 0.3120 | 0.3040 |
| 0.3040 | 0.2900 | 0.3120 | 0.3040 | 0.3200 | 0.3180 |
| 0.2990 | 0.3010 | 0.3070 | 0.3150 | 0.3150 | 0.3290 |

\* Measurement Uncertainty of the Color Coordinates is  $\pm 0.007$

\* Bin Code description

▷ Part Number : SWBF0B

| Bin Code           |     |                 |
|--------------------|-----|-----------------|
| Luminous Intensity | CIE | Forward Voltage |
| S18H               | E2S | z30             |

| Luminous Intensity(mcd)<br>@ $I_F = 20\text{mA}$ |      |      |
|--|------|------|
| Bin Code   | Min. | Max. |
| S15H   | 1500 | 1600 |
| S16H   | 1600 | 1700 |
| S17H   | 1700 | 1800 |
| S18H   | 1800 | 1900 |
| S19H   | 1900 | 2000 |
| S20H   | 2000 | 2100 |
| S21H   | 2100 | 2200 |

| Color Rank<br>@ $I_F = 20\text{mA}$ |
|-------------------------------------|
| A2S                                 |
| C2S                                 |
| E2S                                 |
| G2S                                 |
| I2S                                 |
| K2S                                 |

| Forward Voltage (V)<br>@ $I_F = 20\text{mA}$ |      |      |
|--|------|------|
| Bin Code                                     | Min. | Max. |
| Z28  | 2.8  | 3.0  |
| Z30  | 3.0  | 3.2  |
| Z32  | 3.2  | 3.4  |
| z30  | 3.0  | 3.4  |

□ Available ranks

7. Outline Dimension

( Tolerance:  $\pm 0.1$ , Unit: mm )

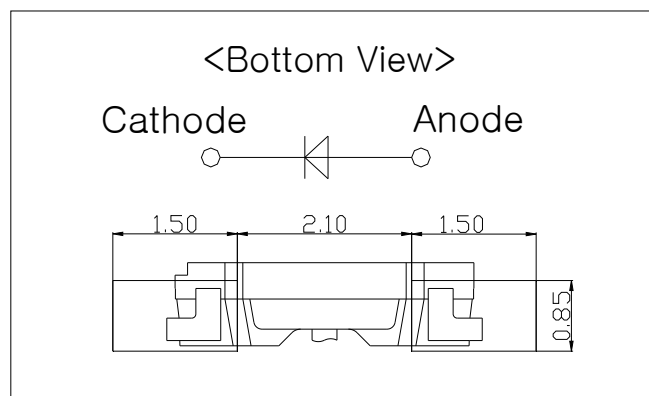
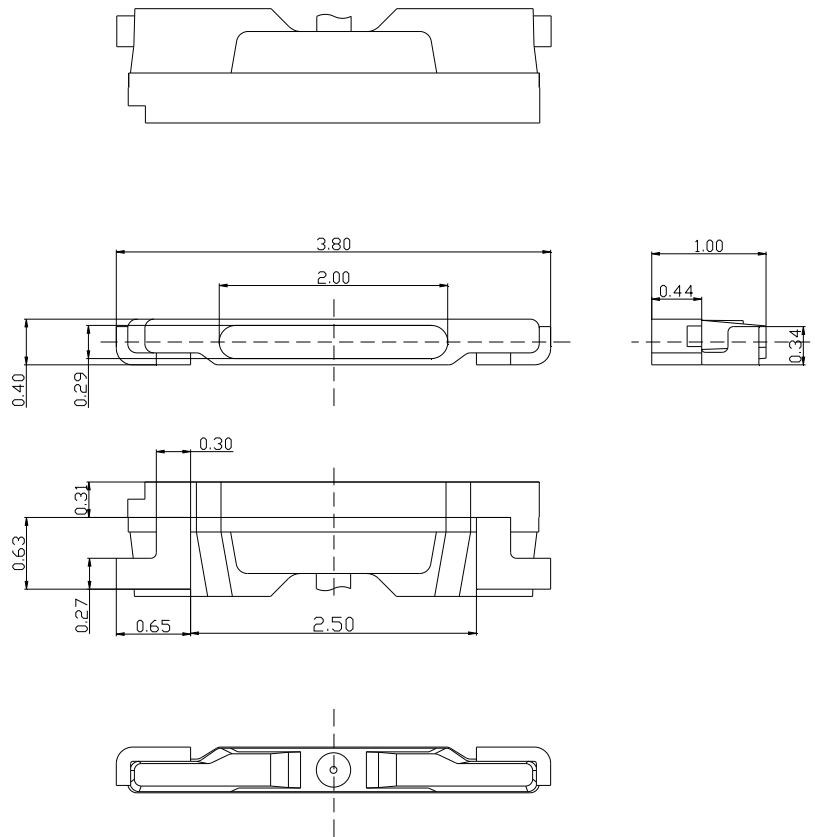

Recommended solder Pattern

8. Material

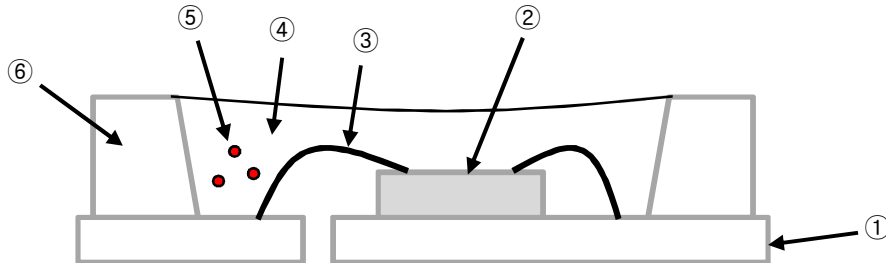

| No. | LIST          | MATERIAL                     |
|-----|---------------|------------------------------|
| ①   | FRAME         | COPPER FRAME (SILVER PLATED) |
| ②   | LED CHIP      | GaN ON SAPPHIRE              |
| ③   | WIRE          | GOLD WIRE                    |
| ④   | ENCAPSULATION | SILICONE                     |
| ⑤   | PHOSPHOR      | SILICATE                     |
| ⑥   | PACKAGE       | HEAT-RESISTANT POLYMER       |

## 9. Packing

### 1) Reel & Carrier

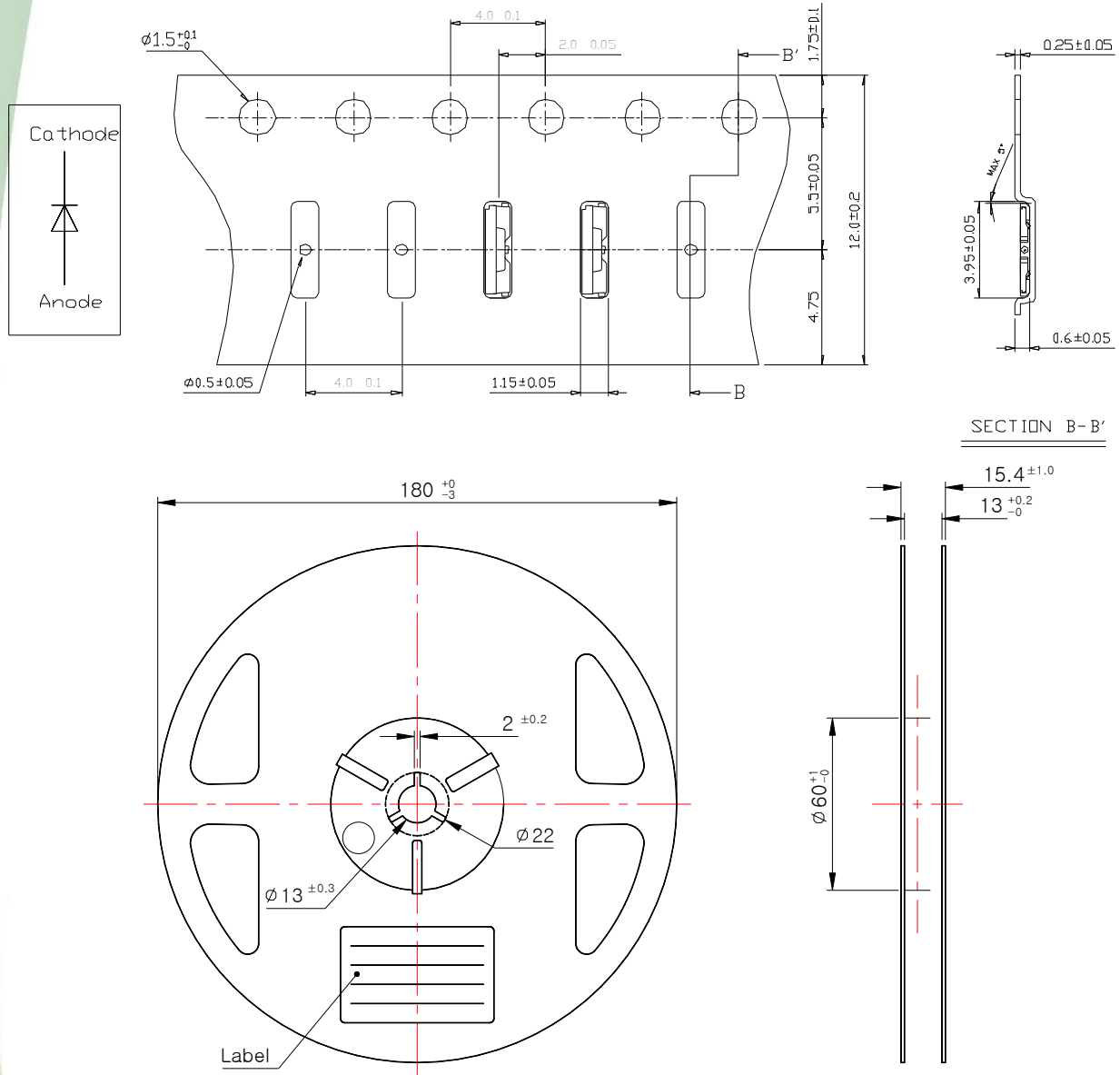

( Tolerance:  $\pm 0.2$ , Unit: mm )

- (1) Quantity : 3500pcs/Reel
- (2) Cumulative Tolerance : Cumulative Tolerance/10 pitches to be  $\pm 0.2$ mm
- (3) Adhesion Strength of Cover Tape : Adhesion strength to be 0.1-0.7N when the cover tape is turned off from the carrier tape at the angle of  $10^\circ$  to the carrier tape
- (4) Package : P/N, Manufacturing data Code No. and quantity to be indicated on a damp proof Package

Rev. 01

February, 2013

www.acrich.com

## 2) Reel Packing Structure

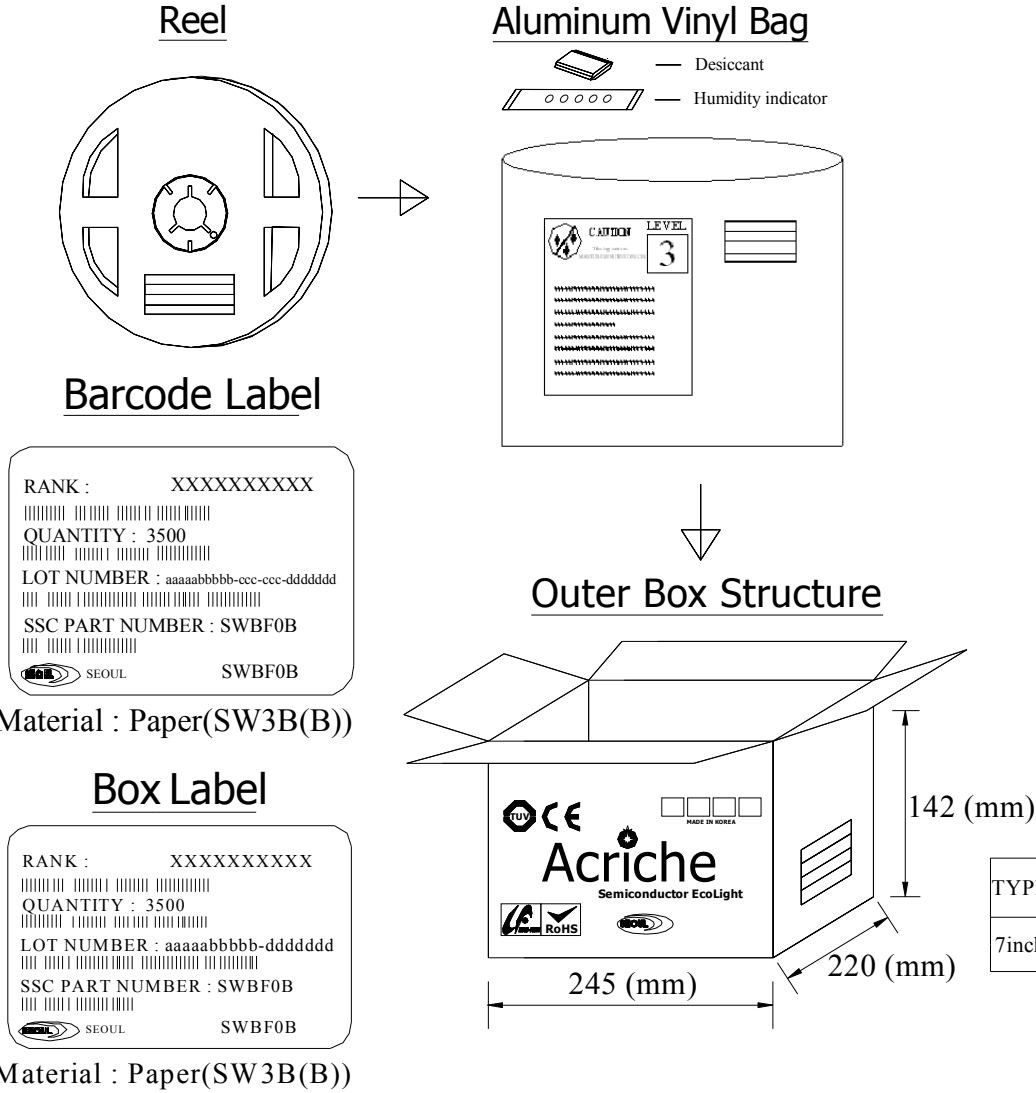

## 3) Lot Number

The lot number is composed of the following characters  
 aaaaabbbb-ccc-ccc-dddddd

| Symbol  | Meaning         | Example                                |
|---------|-----------------|--|
| aaaa    | THE DATE        | 09A23 (Year : 09, A : Month, 23 : day) |
| bbbb    | SSC's Number    | Ex) S0017<br>0001~9999 allowance       |
| ccc-ccc | Order of Taping | 014-001                                |
| dddddd  | SSC's Number    | 7300024(Automatic)                     |

Rev. 01

February, 2013

www.acrich.com

## 10. Soldering

### (1) Lead Solder

| Lead Free Solder         |               |
|--------------------------|---------------|
| Pre-heat                 | 120~150℃      |
| Pre-heat time            | 120 sec. Max. |
| Peak-Temperature         | 240℃ Max.     |
| Soldering time Condition | 10 sec. Max.  |

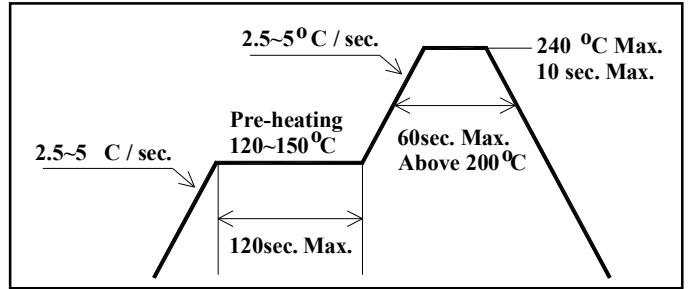

### (2) Lead-Free Solder

| Lead Free Solder         |               |
|--------------------------|---------------|
| Pre-heat                 | 150~200℃      |
| Pre-heat time            | 120 sec. Max. |
| Peak-Temperature         | 260℃ Max.     |
| Soldering time Condition | 10 sec. Max.  |

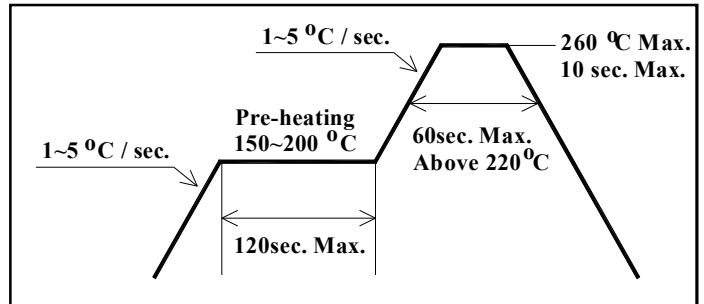

### (3) Hand Soldering conditions

Not more than 3 seconds @MAX 350°C, under Soldering iron.

Note : In case that the soldered products are reused in soldering process, we don't guarantee the products.

Rev. 01

February, 2013

www.acrich.com

## 11. Precaution for use

### (1) Storage conditions

- Keep the product in a dry box or a desiccator with a desiccant in order to prevent moisture absorption.
  - a. Keep it at a temperature in the range from 5°C to 30°C and at a humidity of less than 50% RH.
- The product should be kept within a year.

### (2) After opening the package .

- When soldering, this could result in a decrease of the photoelectric effect or light intensity.
  - a. Soldering should be done right after mounting the product.
  - b. Keep the temperature in the range from 5°C to 30°C and the humidity at less than 60%.
- Soldering should be done within 7 days after opening the desiccant package. If the product has been exposed for more than 7 days after opening the package or the indicating color of the desiccator changes, the product must be baked at a temperature between  $65 \pm 5^\circ\text{C}$  for less than 24 hours.
- An unused and unsealed product should be repacked in a desiccant package and kept sealed in a dry atmosphere.
- Stored at a humidity of less than 10% RH.

### (3) Precautions for use

- Any external mechanical force or excessive vibration should not be applied to the product during cooling after soldering, and it is preferable to avoid rapid cooling.
- The product should not be mounted on a distorted part of PCB.
- Gloves or wrist bands for ESD(Electric Static Discharge) should be wore in order to prevent ESD and surge damage, and all devices and equipments must be grounded to the earth.

### (4) Miscellaneous

- Radiation resistance is not considered.
- When cleaning the product, any kind of fluid such as water, oil and organic solvent must not be used and IPA(Isopropyl Alcohol) must be used.
- When using the product, operating current should be settled in consideration of the maximum ambient temperature.
- Its appearance or specification for improvement is subject to change without notice.