



# Specification

## SPW08F0D

<b>SSC</b>		<b>Customer</b>
Drawn	Approval	Approval

Rev. 0.00

DECEMBER. 2010.

[www.Acriche.com](http://www.Acriche.com)

서식번호 : SSC- QP- 7- 07- 24 (Rev.00)



# SPW08F0D

1. Description
2. Absolute Maximum Ratings
3. Electro- Optical Characteristics
4. Characteristic Diagram
5. Reliability
6. CIE Chromaticity Diagram
7. Binning Table
8. Outline Dimension
9. Reel Structure
10. Packing
11. Soldering
12. Precaution for use
13. Handling of silicon Resin LEDs

Rev. 0.00

DECEMBER. 2010.

[www.Acriche.com](http://www.Acriche.com)

서식번호 : SSC- QP- 7- 07- 24 (Rev.00)

# SPW08F0D

## SPW08F0D

### 1. Description

It has a substrate made up of a molded plastic reflector sitting on top of a bent lead frame (Au Plating).

The die is attached within the reflector cavity and the cavity is encapsulated by silicone

The high reliability feature is crucial to automotive front, Interior lamp and General Lights

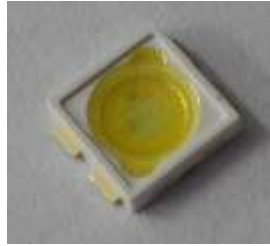

### Features

- Industry Standard SMT package
- Low thermal resistance
- Lead free product
- RoHS Compliant

### Applications

- Daytime running lamp (DRL)
- Position Lamp
- Front Fog Lamp
- Automotive interior lamp
- Interior lighting
- General lighting
- Indoor and outdoor Displays
- Electronic Signs and Signals

Rev. 0.00

DECEMBER. 2010.

[www.Acriche.com](http://www.Acriche.com)

서식번호 : SSC- QP- 7- 07- 24 (Rev.00)

## 2. Absolute Maximum Ratings

Parameter	Symbol	Value	Unit
Power Dissipation*1	$P_d$	2.0	W
Forward Current ( $T_a = 25^\circ\text{C}$ )	$I_F$	100 (min.) 350 (typ.) 500 (max.)	mA
Operating Temperature	$T_{opr}$	-40 ~ +125	$^\circ\text{C}$
Storage Temperature	$T_{stg}$	-40 ~ +125	$^\circ\text{C}$
Junction Temperature	$T_j$	150	$^\circ\text{C}$
Thermal Resistance*2	$R_{th-JA}$	40	K/W
	$R_{th-JS}$	12	K/W

\*1. Care is to be taken that power dissipation does not exceed the absolute maximum rating of the product.

\*2. Mounted on Metal PCB, Area of 950mm<sup>2</sup> per LED.  $R_{th-JC}$  is Junction to case (bottom of metal PCB) temp.

## 3. Electro-Optical characteristics

Parameter	Symbol	Condition	Min	Typ	Max	Unit
Forward Voltage	$V_F$	$I_F = 350\text{mA}$	-	3.5	3.8	V
Luminance Flux *1	$\Phi_V$	$I_F = 350\text{mA}$	70	-	91	lm
Color Coordinate (x,y) *2	x	$I_F = 350\text{mA}$	-	0.33	-	-
	y		-	0.33	-	
Viewing Angle *3	$2\theta_{1/2}$	$I_F = 350\text{mA}$	120			deg.

\*1. The luminous Flux was measured at the peak of the spatial pattern which may not be aligned with the mechanical axis of the LED package. Luminous Flux Measurement allowance is  $\pm 10\%$

\*2. Measurement Uncertainty of the Color Coordinates is  $\pm 0.01$

\*3.  $2\theta_{1/2}$  is the off- axis where the luminous intensity is 1/2 of the peak intensity.

### 4. Characteristic Diagram

Forward Current vs. Forward Voltage

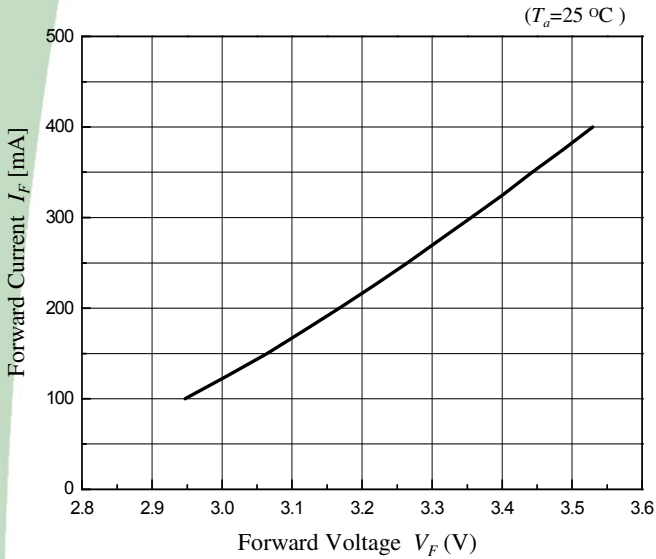

Relative Luminous Intensity vs Forward Current

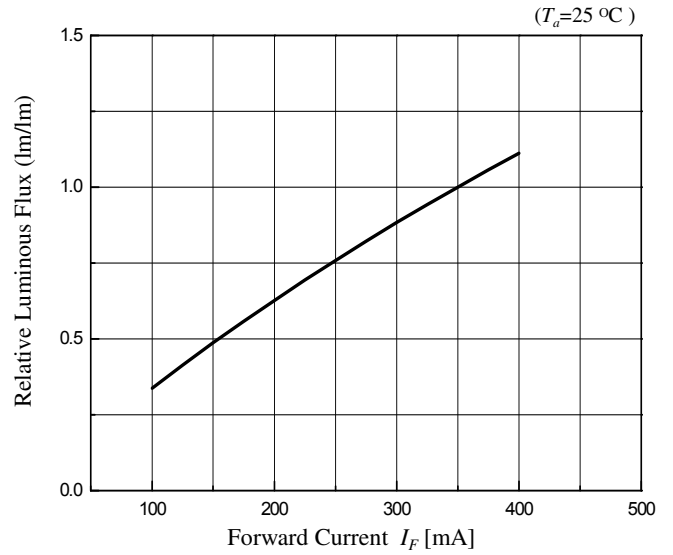

Color Coordinate Shift vs. Forward Current

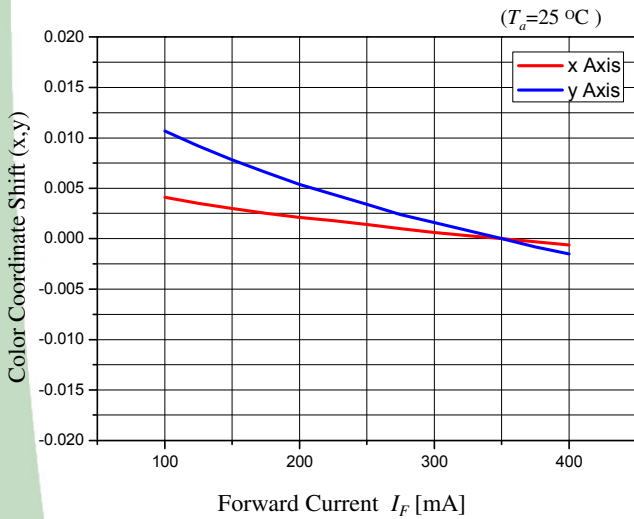

Spectrum

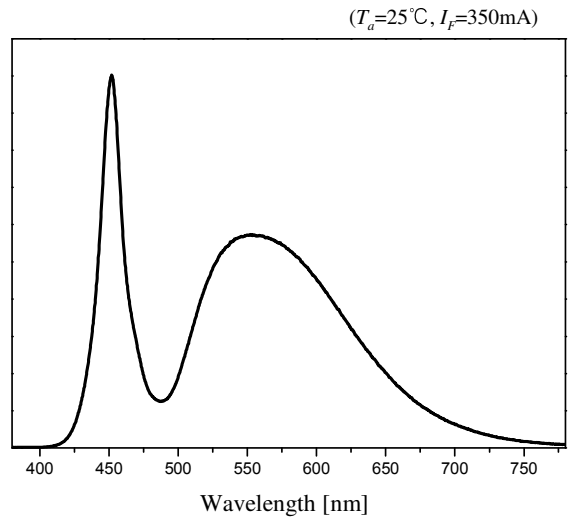

### 4. Characteristic Diagram

Relative Forward Voltage vs. Junction Temperature

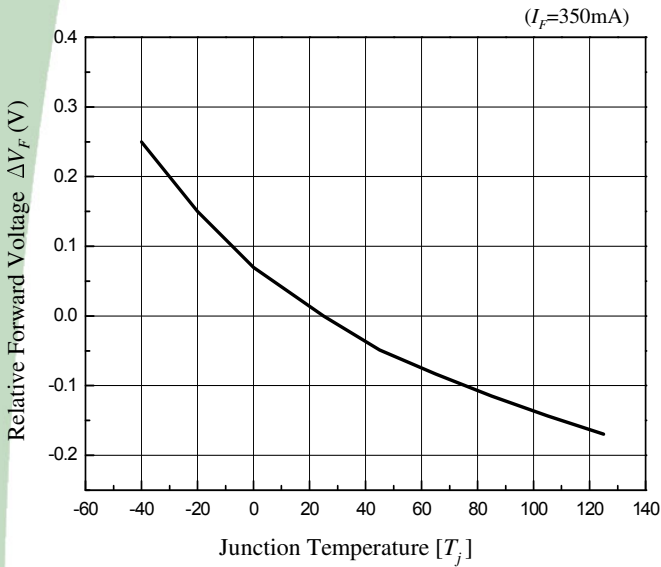

Relative Luminous Intensity vs. Junction Temperature

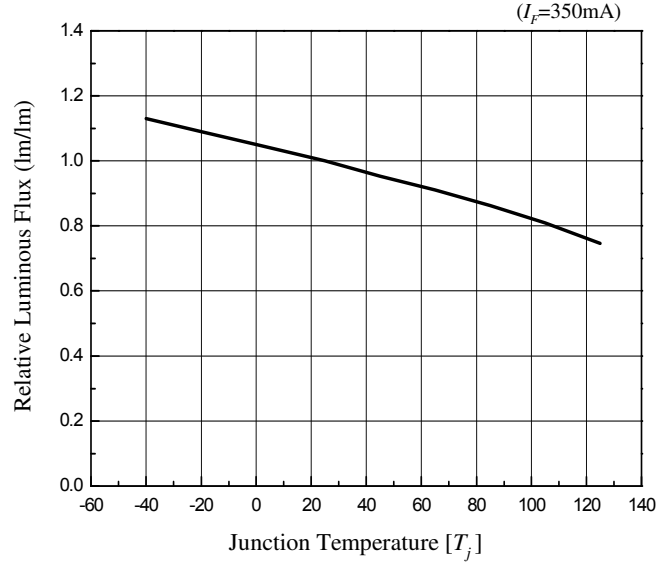

Color Coordinate Shift vs. Junction Temperature

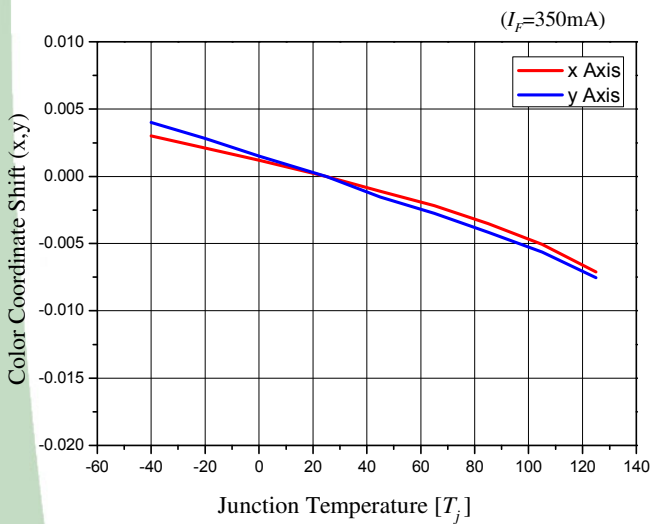

Radiation Diagram

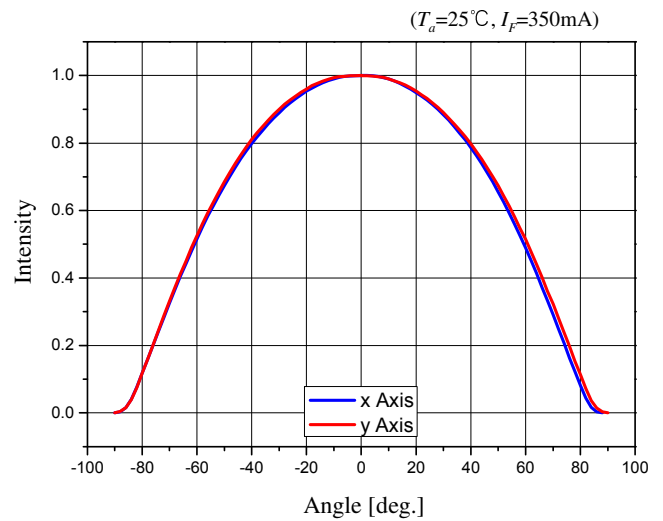

### 4. Characteristic Diagram

Max. Permissible Forward Current

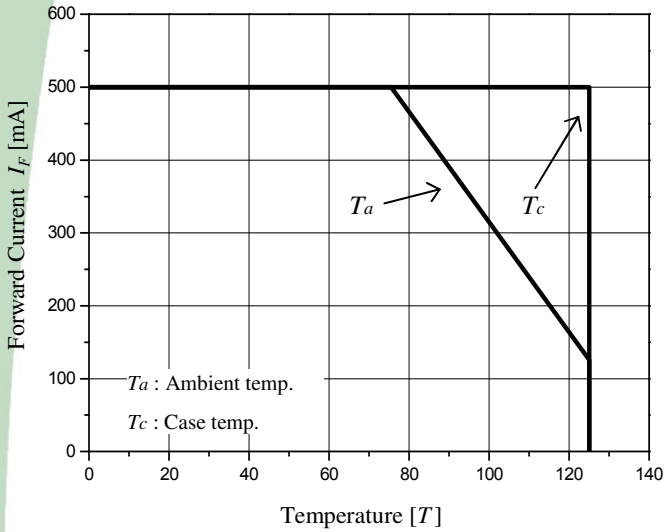

## 5. Reliability

Stress	Reference Specification	Test Description (as performed by supplier)	Duration / Cycle	Number of Damage
Thermal Shock	JESD22 A-104	-40°C/100°C, 20 min dwell, <10 second transfer	1000 Cycle	0/77
Temperature Cycling	JESD22 A-104	Tc= -40°~100°C, 30 min dwell, 5 min transfer	1000 Cycle	0/77
Power and Temperature Cycle	JESD22 A-105	Tc=-40°C/100°C, If =350 mA, 10 min dwell / 20 min transition (1 hour cycle), 2 min ON / 2 min OFF, 1000 cycles	1000 Cycle	0/77
Low Temperature Operating Life	JESD22 A-108C	Ta= -40°C, If = 350 mA	1000 hours	0/77
Room Temperature Operating Life	-	Ta= 25°C, If = 350 mA	1000 hours	0/77
High Temperature Operating Life	JESD22 A-108C	Ta= 100°C, If = 300 mA	1000 hours	0/77
High Humidity High Temp. Reverse Bias	JESD22 A-101	85°C/85% RH, If = 350 mA	1000 hours	0/77
Low Temperature Storage Life	JESD22 A-119	Ta= -40°C	1000 hours	0/77
High Temperature Storage Life	JESD22 A-103B	Ta=100°C	1000 hours	0/77
ESD Characterization	AEC-Q101-001, 002, 005	HBM = 2kV	-	0/30
Vibration Variable Frequency	JESD22 B-103	0.06 inch displacement, 20 to 100 Hz, 50g 100 Hz to 2kHz,	-	0/30
Mechanical Shock	JESD22 B-104	1500 g's for 0.5 ms, 5 blows, 3 orientations	-	0/30

### Criteria for Judging the Damage

Item	Symbol	Condition	Criteria for Judgement	
			MIN	MAX
Forward Voltage	$V_F$	$I_F = 350\text{mA}$	$LSL^{*2} \times 0.8$	$USL^{*1} \times 1.2$
Luminous Flux	$\Phi_V$	$I_F = 350\text{mA}$	$LSL^{*2} \times 0.8$	$USL^{*1} \times 1.2$

Note : \*1 USL : Upper Standard Level

\*2 LSL : Lower Standard Level

### 6. CIE Chromaticity Diagram

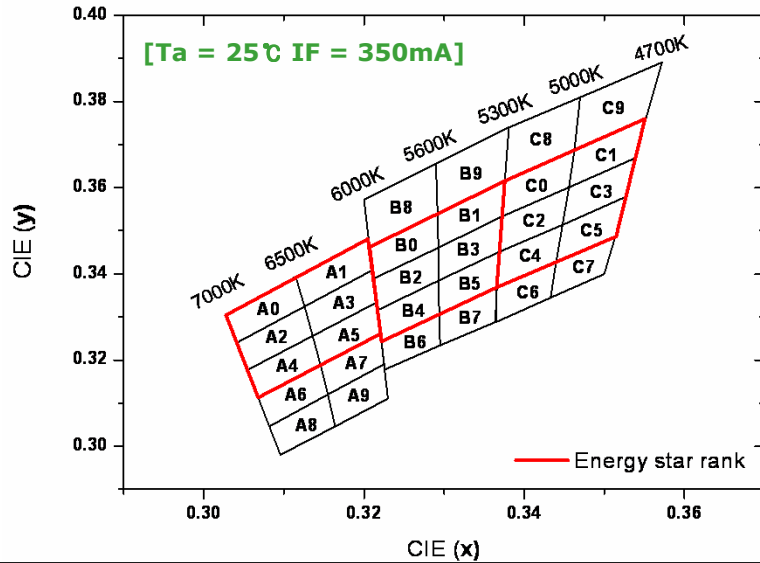

A0		A2		A4		A6		A8	
CIE x	CIE y	CIE x	CIE y	CIE x	CIE y	CIE x	CIE y	CIE x	CIE y
0.3028	0.3304	0.3041	0.3240	0.3055	0.3177	0.3068	0.3113	0.3082	0.3046
0.3041	0.3240	0.3055	0.3177	0.3068	0.3113	0.3082	0.3046	0.3096	0.2980
0.3126	0.3324	0.3136	0.3256	0.3146	0.3187	0.3155	0.3120	0.3164	0.3046
0.3115	0.3393	0.3126	0.3324	0.3136	0.3256	0.3146	0.3187	0.3155	0.3120
A1		A3		A5		A7		A9	
CIE x	CIE y	CIE x	CIE y	CIE x	CIE y	CIE x	CIE y	CIE x	CIE y
0.3115	0.3393	0.3126	0.3324	0.3136	0.3256	0.3146	0.3187	0.3155	0.3120
0.3126	0.3324	0.3136	0.3256	0.3146	0.3187	0.3155	0.3120	0.3164	0.3046
0.3210	0.3408	0.3216	0.3334	0.3221	0.3261	0.3225	0.3190	0.3230	0.3110
0.3205	0.3481	0.3210	0.3408	0.3216	0.3334	0.3221	0.3261	0.3225	0.3190
B8		B0		B2		B4		B6	
CIE x	CIE y	CIE x	CIE y	CIE x	CIE y	CIE x	CIE y	CIE x	CIE y
0.3200	0.3572	0.3207	0.3462	0.3212	0.3389	0.3217	0.3316	0.3222	0.3243
0.3207	0.3462	0.3212	0.3389	0.3217	0.3316	0.3222	0.3243	0.3226	0.3178
0.3292	0.3539	0.3293	0.3461	0.3293	0.3384	0.3294	0.3306	0.3295	0.3234
0.3290	0.3656	0.3292	0.3539	0.3293	0.3461	0.3293	0.3384	0.3294	0.3306
B9		B1		B3		B5		B7	
CIE x	CIE y	CIE x	CIE y	CIE x	CIE y	CIE x	CIE y	CIE x	CIE y
0.3290	0.3656	0.3292	0.3539	0.3293	0.3461	0.3293	0.3384	0.3294	0.3306
0.3292	0.3539	0.3293	0.3461	0.3293	0.3384	0.3294	0.3306	0.3295	0.3234
0.3376	0.3616	0.3373	0.3534	0.3369	0.3451	0.3366	0.3369	0.3364	0.3288
0.3381	0.3740	0.3376	0.3616	0.3373	0.3534	0.3369	0.3451	0.3366	0.3369
C8		C0		C2		C4		C6	
CIE x	CIE y	CIE x	CIE y	CIE x	CIE y	CIE x	CIE y	CIE x	CIE y
0.3381	0.3740	0.3376	0.3616	0.3373	0.3534	0.3369	0.3451	0.3366	0.3369
0.3376	0.3616	0.3373	0.3534	0.3369	0.3451	0.3366	0.3369	0.3364	0.3288
0.3463	0.3687	0.3456	0.3601	0.3448	0.3514	0.3440	0.3428	0.3433	0.3345
0.3470	0.3810	0.3463	0.3687	0.3456	0.3601	0.3448	0.3514	0.3440	0.3428
C9		C1		C3		C5		C7	
CIE x	CIE y	CIE x	CIE y	CIE x	CIE y	CIE x	CIE y	CIE x	CIE y
0.3470	0.3810	0.3463	0.3687	0.3456	0.3601	0.3448	0.3514	0.3440	0.3428
0.3463	0.3687	0.3456	0.3601	0.3448	0.3514	0.3440	0.3428	0.3433	0.3345
0.3552	0.3760	0.3539	0.3669	0.3526	0.3578	0.3514	0.3487	0.3500	0.3400
0.3572	0.3891	0.3552	0.3760	0.3539	0.3669	0.3526	0.3578	0.3514	0.3487

v. 0.00  
2010.

### 7. Binning Table

Bin Code		
Luminous Flux (lm) @ $I_F = 350\text{mA}$	Color Chromaticity Coordinate @ $I_F = 350\text{mA}$	Forward Voltage (V) @ $I_F = 350\text{mA}$
T1	B0	I

↓

Luminous Flux (lm) @ $I_F = 350\text{mA}$		
Bin Code	Min.	Max.
S2	60	70
T1	70	80
T2	80	91

↓

Color Chromaticity Coordinate @ $I_F = 350\text{mA}$		
Bin Code	Min.	Max.
Ref. 9 pages		

↓

Forward Voltage (V) @ $I_F = 350\text{mA}$		
Bin Code	Min.	Max.
H	3.0	3.2
I	3.2	3.4
J	3.4	3.6
K	3.6	3.8

Available ranks

### 8. Outline dimension

#### < Package Outline >

(Tolerance:  $\pm 0.2$ , Unit: mm)

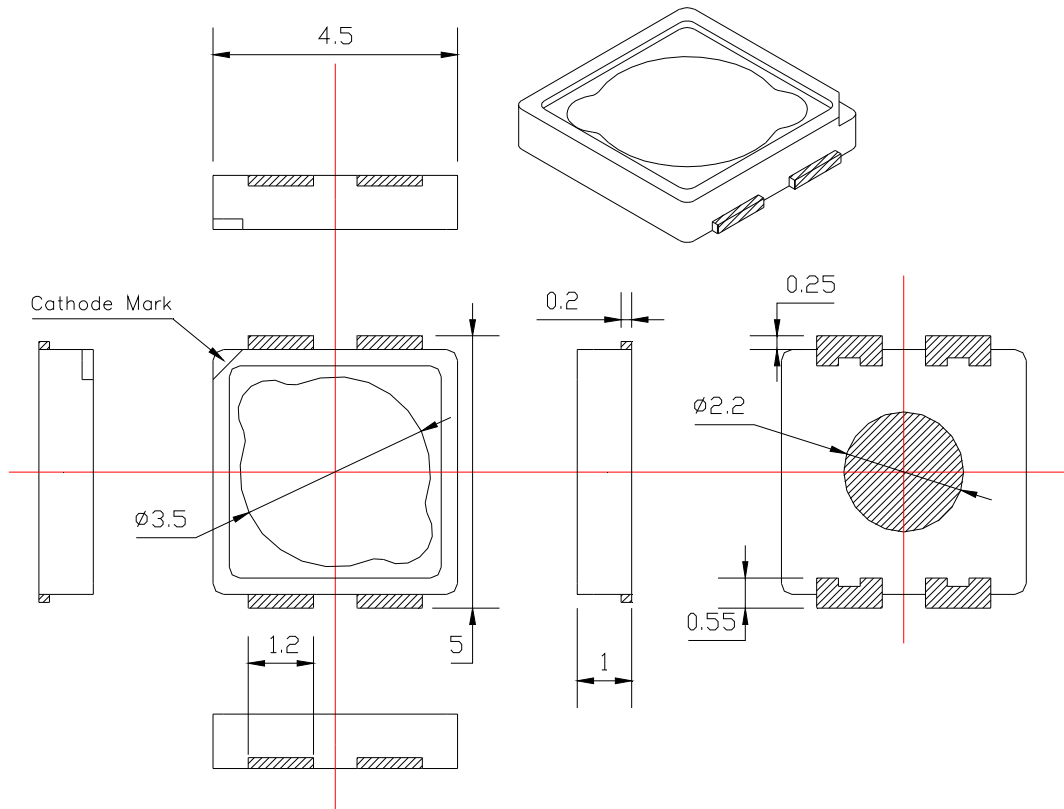

#### < Circuit Diagram >

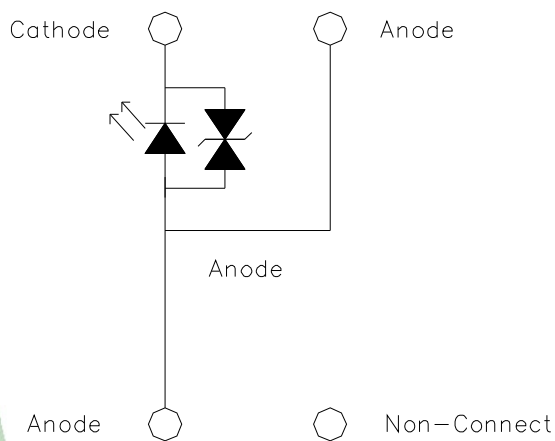

#### < Solder Pattern >

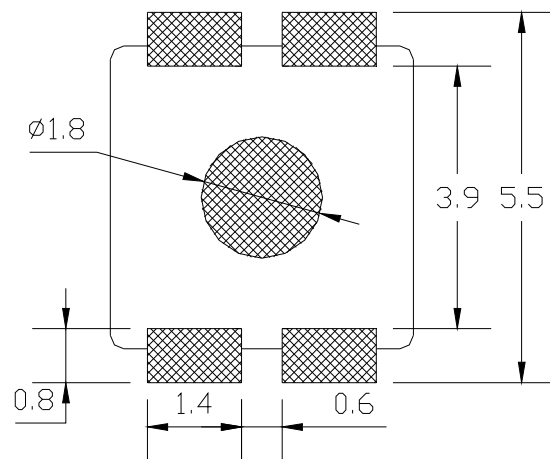

### 9. Reel Structure

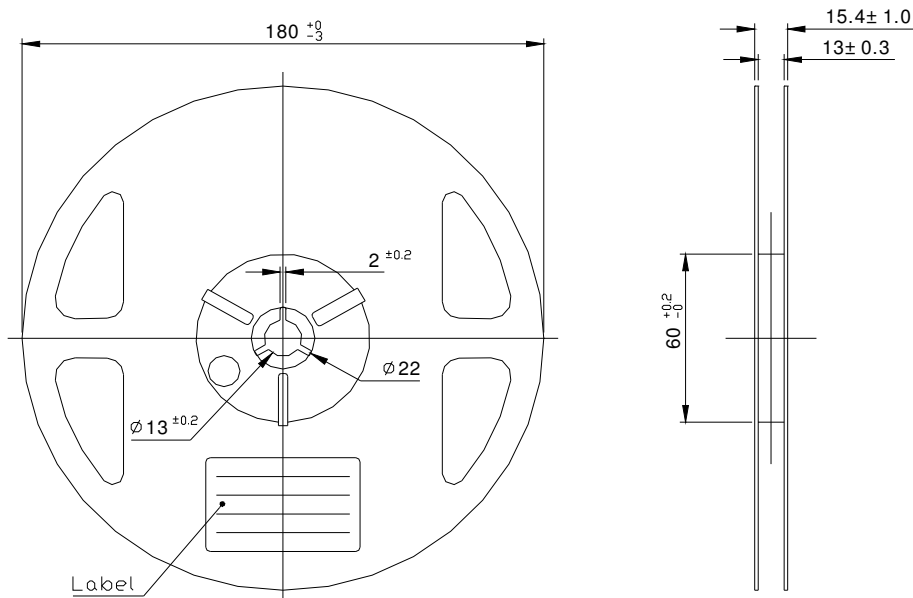
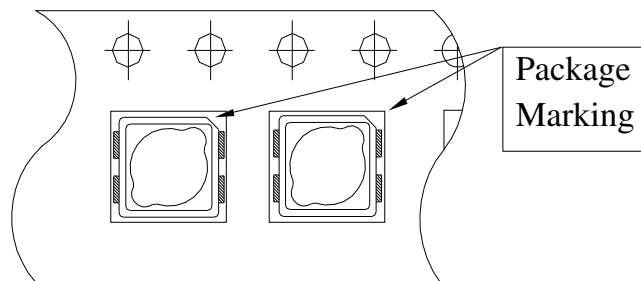
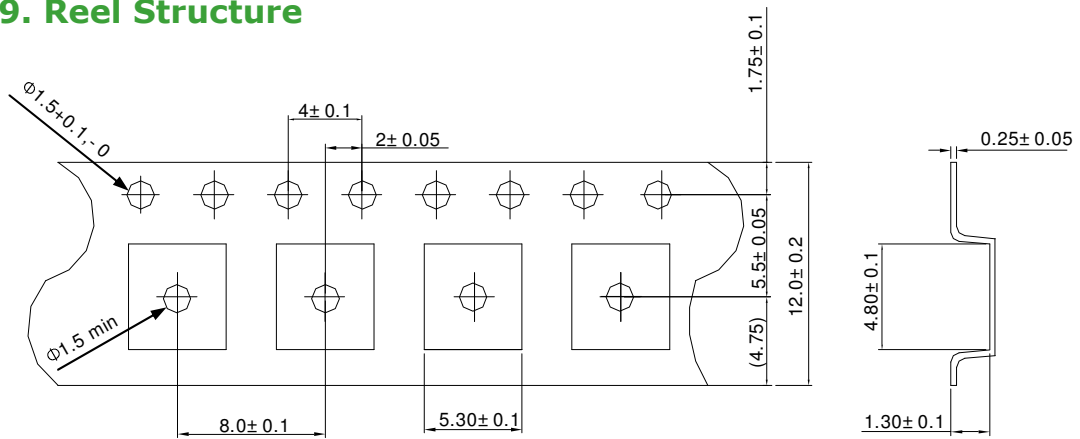

( Tolerance:  $\pm 0.2$ , Unit: mm )

- (1) Quantity : 1,500pcs/Reel
- (2) Cumulative Tolerance : Cumulative Tolerance/10 pitches to be  $\pm 0.2\text{mm}$
- (3) Adhesion Strength of Cover Tape : Adhesion strength to be 0.1-0.7N when the cover tape is turned off from the carrier tape at the angle of  $10^\circ$  to the carrier tape
- (4) Package : P/N, Manufacturing data Code No. and quantity to be indicated on a damp proof Package

Rev. 0.00

DECEMBER. 2010.

www.Acriche.com

서식번호 : SSC- QP- 7- 07- 24 (Rev.00)

### 10. Packing

#### Reel

RANK: XXX  
 QUANTITY: XXXX  
 LOT NUMBER: XXXXXXXXXXXX  
 PART NUMBER: XXXXXX  
 SEOUL SEMICONDUCTOR CO., LTD.

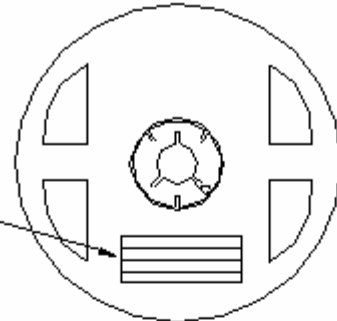

#### Aluminum Vinyl Bag

RANK: XXX  
 QUANTITY: XXXX  
 LOT NUMBER: XXXXXXXXXXXX  
 PART NUMBER: XXXXXX  
 SEOUL SEMICONDUCTOR CO., LTD.

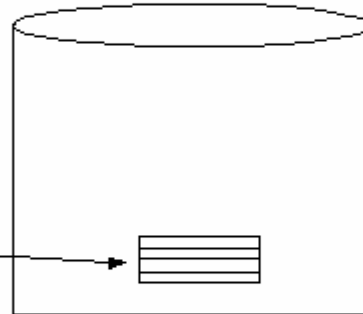

#### Outer Box Structure

Material : Paper(SW3B(B))

TYPE	SIZE (mm)		
	Ⓐ	Ⓑ	Ⓒ
7inch	245	220	142
7inch	245	220	80

#### Ⓐ SIDE

RANK: XXX  
 QUANTITY: XXXX  
 LOT NUMBER: XXXXXXXXXXXX  
 PART NUMBER: XXXXXX  
 SEOUL SEMICONDUCTOR CO., LTD.

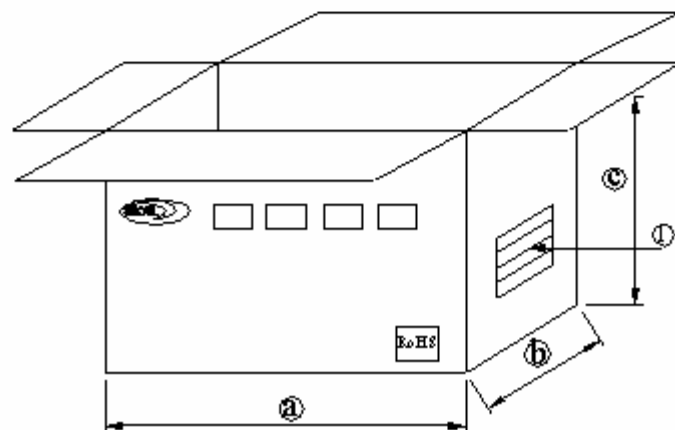

## 11. Soldering

### (1) Lead Solder

Lead Solder	
Pre-heat	120~150 ℃
Pre-heat time	120 sec. Max.
Peak-Temperature	240 ℃ Max.
Soldering time Condition	10 sec. Max.

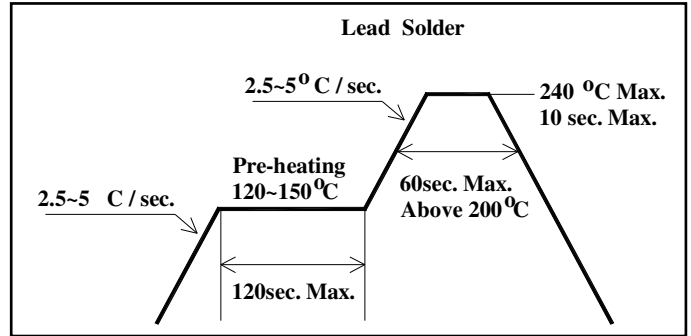

### (2) Lead-Free Solder

Lead Free Solder	
Pre-heat	150~200 ℃
Pre-heat time	120 sec. Max.
Peak-Temperature	260 ℃ Max.
Soldering time Condition	10 sec. Max.

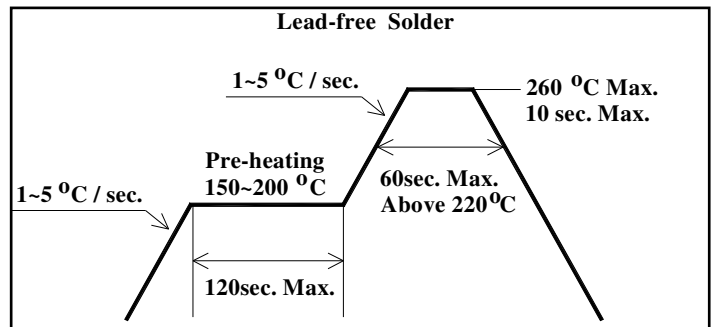

### (3) Hand Soldering conditions

Do not exceed 4 seconds at maximum 315°C under soldering iron.

### (4) The encapsulated material of the LEDs is silicone.

Precautions should be taken to avoid the strong pressure on the encapsulated part.

So when using the chip mounter, the picking up nozzle that does not affect the silicone resign should be used.

Note : In case that the soldered products are reused in soldering process, we don't guarantee the products.

## 12. precaution for use

### (1) Storage

In order to avoid the absorption of moisture, it is recommended to store in a dry box with a desiccant. Otherwise, to store them in the following environment is recommended.

Temperature : 5°C ~30°C Humidity : maximum 70%RH

### (2) Attention after open.

LED is correspond to SMD, when LED be soldered dip, interfacial separation may affect the light transmission efficiency, causing the light intensity to drop. Attention in followed; Keeping of a fraction

Temperature : 5 ~ 40°C Humidity : less than 10%

(3) In the case of more than 4 week passed after opening or change color of indicator on desiccant, components shall be dried 10-12hr. at 60± 5°C.

(4) Any mechanical force or any excess vibration shall not be accepted to apply during cooling process to normal temperature after soldering.

(5) Quick cooling shall be avoided.

(6) Components shall not be mounted on warped direction of PCB.

(7) Anti radioactive ray design is not considered for the products.

(8) This device should not be used in any type of fluid such as water, oil, organic solvent etc. When washing is required, IPA should be used.

(9) When the LEDs are illuminating, operating current should be decided after considering the ambient maximum temperature.

(10) The LEDs must be soldered within seven days after opening the moisture-proof packing.

(11) Repack unused products with anti-moisture packing, fold to close any opening and then store in a dry place.

(12) The appearance and specifications of the product may be modified for improvement without notice.

(13) Silver plating becomes tarnished when being exposed to an environment which contains corrosive gases any product with tarnished leads may lead to poor solderability and deterioration of optical characteristics . Please do not expose the product to corrosive atmosphere during storage

### 13. Handling of Silicone Resin LEDs

(1) During processing, mechanical stress on the surface should be minimized as much as possible. Sharp objects of all types should not be used to pierce the sealing compound.



(2) In general, LEDs should only be handled from the side. By the way, this also applies to LEDs without a silicone sealant, since the surface can also become scratched.

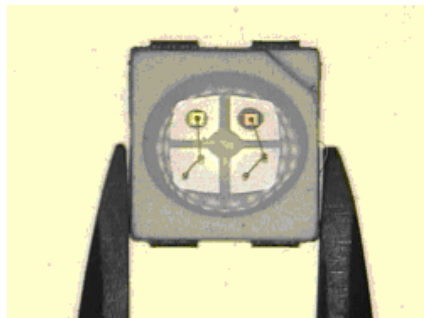

(3) When populating boards in SMT production, there are basically no restrictions regarding the form of the pick and place nozzle, except that mechanical pressure on the surface of the resin must be prevented. This is assured by choosing a pick and place nozzle which is larger than the LED's reflector area.

(4) Silicone differs from materials conventionally used for the manufacturing of LEDs. These conditions must be considered during the handling of such devices. Compared to standard encapsulants, silicone is generally softer, and the surface is more likely to attract dust.

As mentioned previously, the increased sensitivity to dust requires special care during processing. In cases where a minimal level of dirt and dust particles cannot be guaranteed, a suitable cleaning solution must be applied to the surface after the soldering of components.

(5) SSC suggests using isopropyl alcohol for cleaning. In case other solvents are used, it must be assured that these solvents do not dissolve the package or resin. Ultrasonic cleaning is not recommended. Ultrasonic cleaning may cause damage to the LED.