

# Specification

## Acrich2 – 13W

---

**SMJE-2V12W1P3 (120V)**

---

**SMJE-3V12W1P3 (220V)**

---

## Acrich2 - 13W

### Description

The Acrich2 series of products are designed to be driven directly off of AC line voltage, therefore they do not need the standard converter essential for conventional general lighting products.

The converter or driver found in most general lighting products can limit the overall life of the product, but with the Acrich2 series of products the life of the product can more closely be estimated from the LED itself.

This will also allow for a much smaller form factor from an overall fixture design allowing for higher creativity in the fixture.

The modules have a high power factor which can contribute to a higher energy savings in the end application.

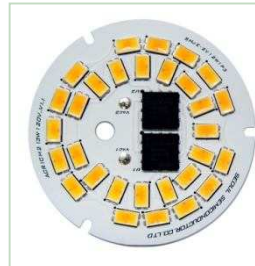

## Acrich2

### Features

- Connects directly to AC line voltage
- High Power Efficiency
- High Power Factor
- Low THD
- Long Life Time
- Simple BOM
- Miniaturization
- Lead Free product
- RoHS compliant

### Applications

- Bulb light
- Down light
- Factory Ceiling light
- Industrial Light

## [ Contents ]

- 1. Characteristics**
- 2. Thermal Resistance**
- 3. Color spectrum**
- 4. Power characteristics**
- 5. Radiation pattern**
- 6. Binning Structure**
- 7. Marking**
- 8. Part List**
- 9. Outline dimensions**
- 10. Circuit Drawing**
- 11. Packing**
- 12. Cautions for use**
- 13. Handling of silicone resin for LEDs**
- 14. Handling with regards to static electricity**
- 15. Storage before use**
- 16. Guidelines for properly working with Acrich2**

## 1. Characteristics

### 1-1. Electro-Optical characteristics of Acrich2 13W

Parameter	Symbol	Mark	Value			Unit
			Min	Typ	Max	
Luminous Flux <sup>[2]</sup>	$\Phi_v$ <sup>[3]</sup>	13a	880	1000	1140	lm
		13b	1140	1210	1300	
		13c	1300	1360	-	
Correlated Color Temperature <sup>[4]</sup>	CCT	B	5300	5600	6000	K
		C	4700	5000	5300	
		E	3700	4000	4200	
		G	2900	3000	3200	
		H	2600	2700	2900	
CRI	$R_a$		80	-	-	-
Operating Voltage <sup>[5]</sup>	$V_{opt}$			120		V[RMS]
				220		
Power Dissipation	$P_D$		12.5	13.0	13.5	W
Operating Frequency	Freq			50 / 60		Hz
Power Factor	PF			Over 0.95		-
View Angle	$2\theta$ 1/2			120		deg.

### 1-2. Absolute Maximum Ratings

Parameter	Symbol	Raged Voltage	Value	Unit
Max. Voltage	$V_{opt}$	120V	140	V[RMS]
		220V	264	
Power Dissipation	$P_d$		17.5	W
Operating Temperature	$T_{opr}$		-30 ~ 85	°C
Storage Temperature	$T_{stg}$		-40 ~ 100	°C
ESD Sensitivity	-		±4,000V HBM	-

**\* Notes :**

- [1] At 120V and 220V RMS,  $T_a=25^{\circ}\text{C}$
- [2] Acrich2 series maintain the tolerance of  $\pm 10\%$  on flux and power measurements.
- [3]  $\Phi_v$  is the total luminous flux output measured with an integrated sphere.
- [4] Correlated Color Temperature is derived from the CIE 1931 Chromaticity diagram.
- [5] Operating Voltage doesn't indicate the maximum voltage which customers use but means tolerable voltage according to each country's voltage variation rate.  
It is recommended that the solder pad temperature should be below  $70^{\circ}\text{C}$ .

## 2. Thermal Resistance

Part	Package Power Dissipation [W]	Maximum Junction Temp[°C]	R $\theta_{j-s}$ [°C/W]
Acrich2 LED	SAW8KG0B Max 0.5	125	27
Acrich2 IC	Max 1.0	125	16.4

The Acrich2 LED has a thermal resistance of 27°C/W from junction of the LED to the LED lead.

The maximum junction temperature of the Acrich2 LED package is 125°C, therefore the maximum lead temperature T<sub>s\_max</sub> is

$$T_{s\_max} = T_{j\_max} - (R\theta_{j-s} * P_D)$$

$$= 125^\circ\text{C} - (27^\circ\text{C/W} * 0.5\text{W}) = 111.5^\circ\text{C}$$

Although this is the maximum lead temperature, it is recommended to keep the lead temperature under 70°C

The Acrich2 IC has a 16.4°C/W thermal resistance from junction to the top surface.

The maximum junction temperature (T<sub>t\_max</sub>) of the IC is 125°C, therefore the maximum temperature of the top of the IC is

$$T_{t\_max} = T_{j\_max} - (\psi_{j-t} * P_D)$$

$$= 125^\circ\text{C} - (16.4^\circ\text{C/W} * 1.0\text{W}) = 108.6^\circ\text{C}$$

### 3. Color spectrum

**Relative Spectral Distribution vs. Wavelength Characteristic – G, H**

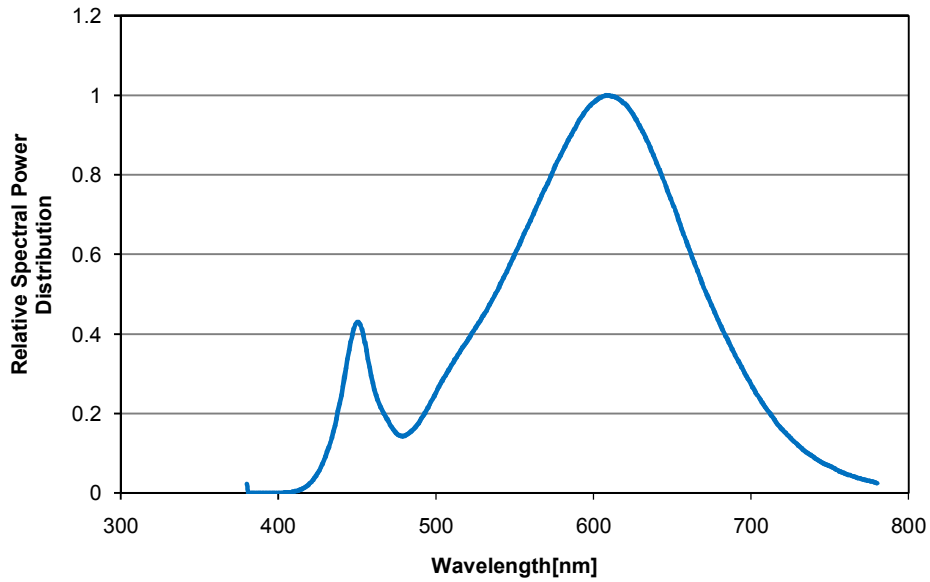

**Relative Spectral Distribution vs. Wavelength Characteristic - E**

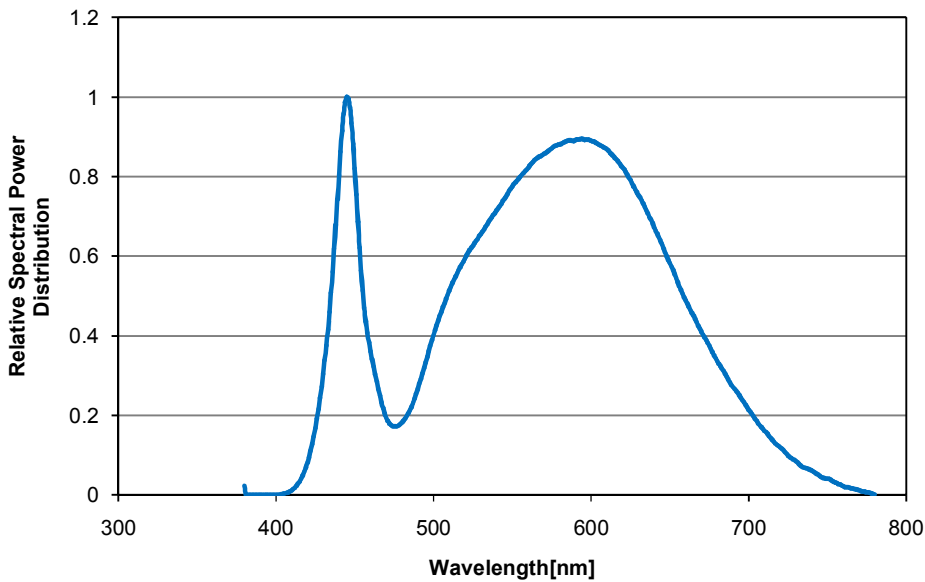

**Relative Spectral Distribution vs. Wavelength Characteristic – B, C**

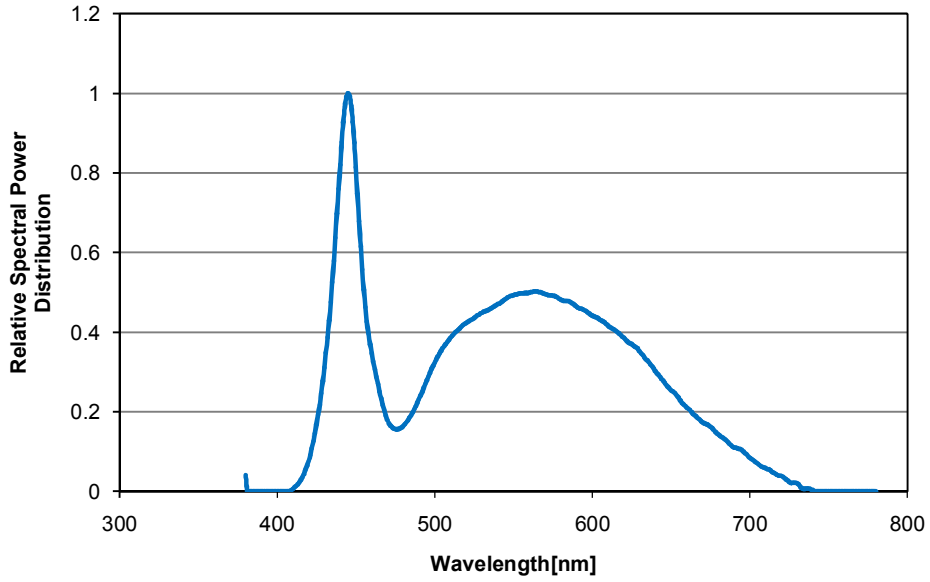

## 4. Power characteristic

Relative Power Distribution vs. Voltage at Ta=25°C

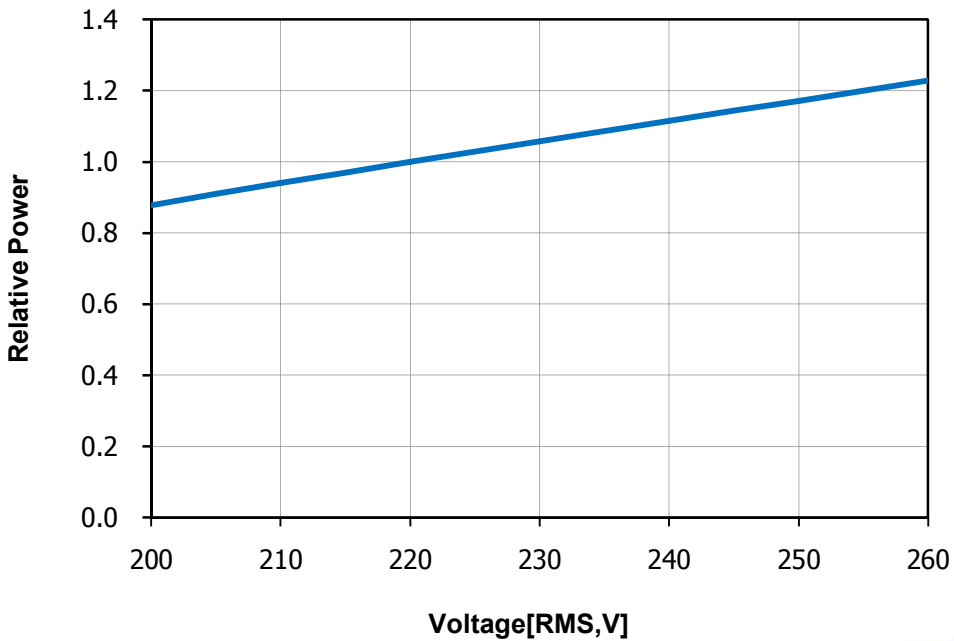
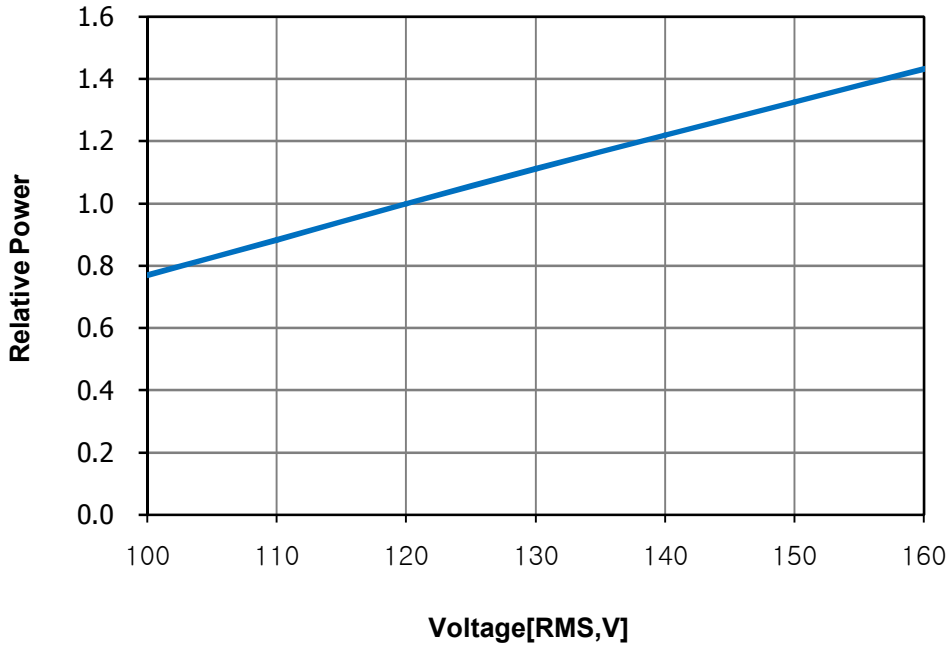

**Relative Luminous flux vs. Voltage at Ta=25°C**

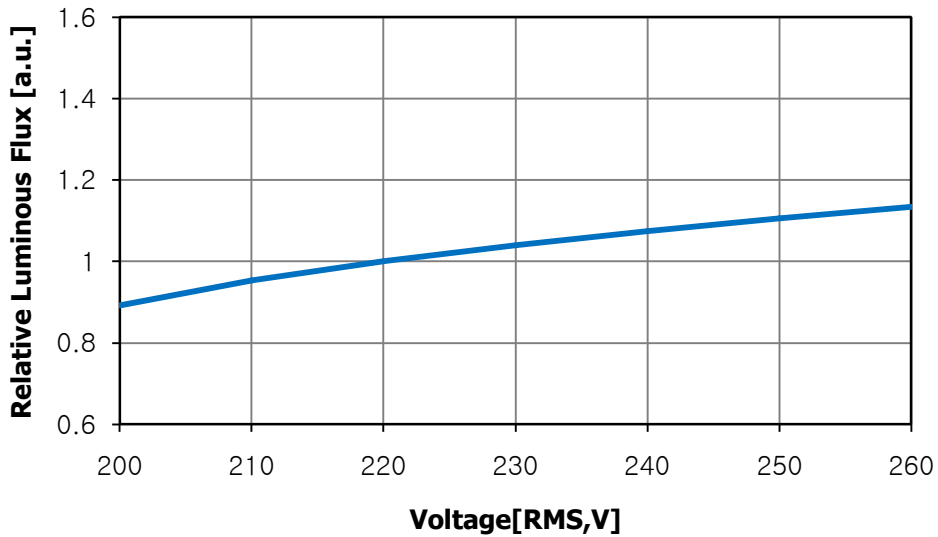
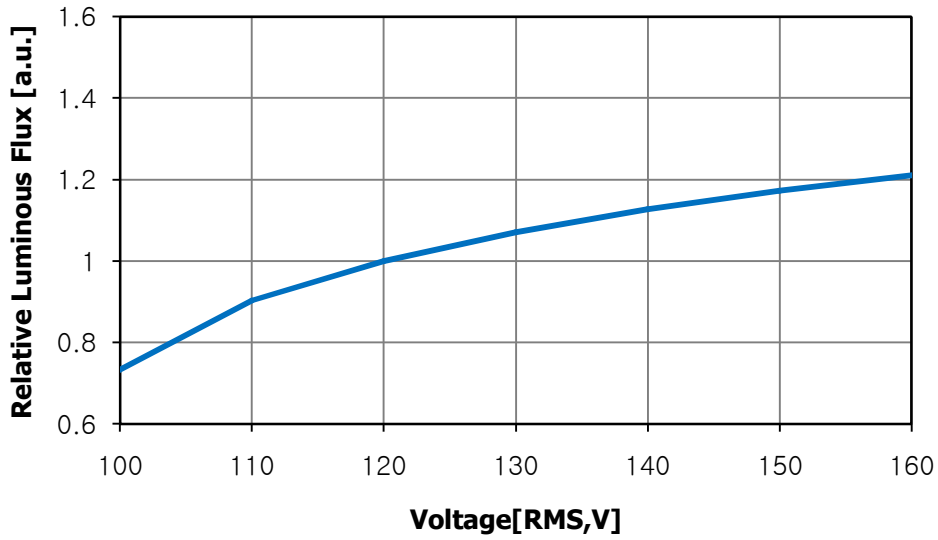

## 5. Radiation Pattern

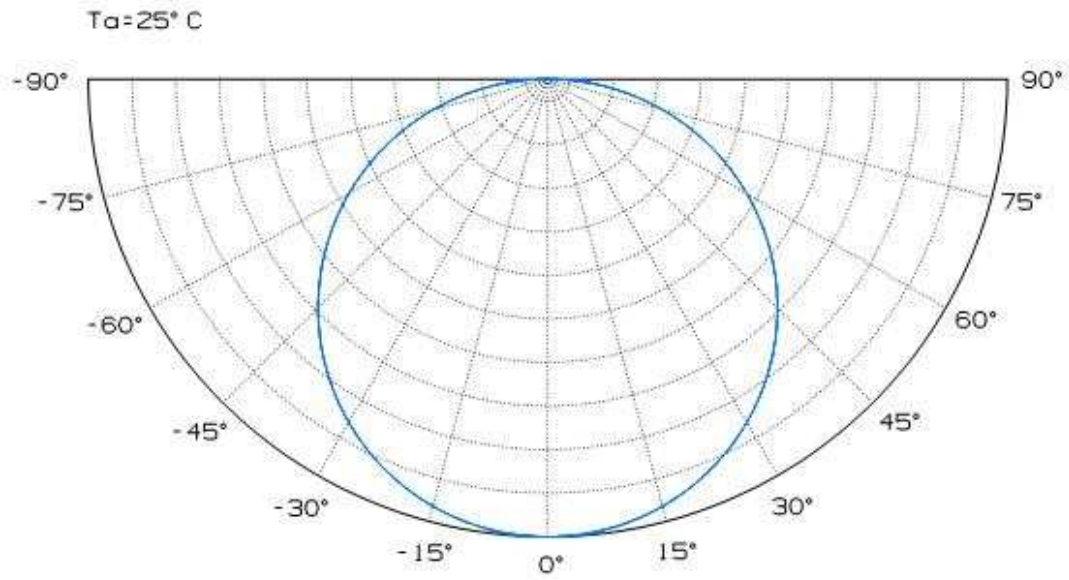

## 6. Binning Structure

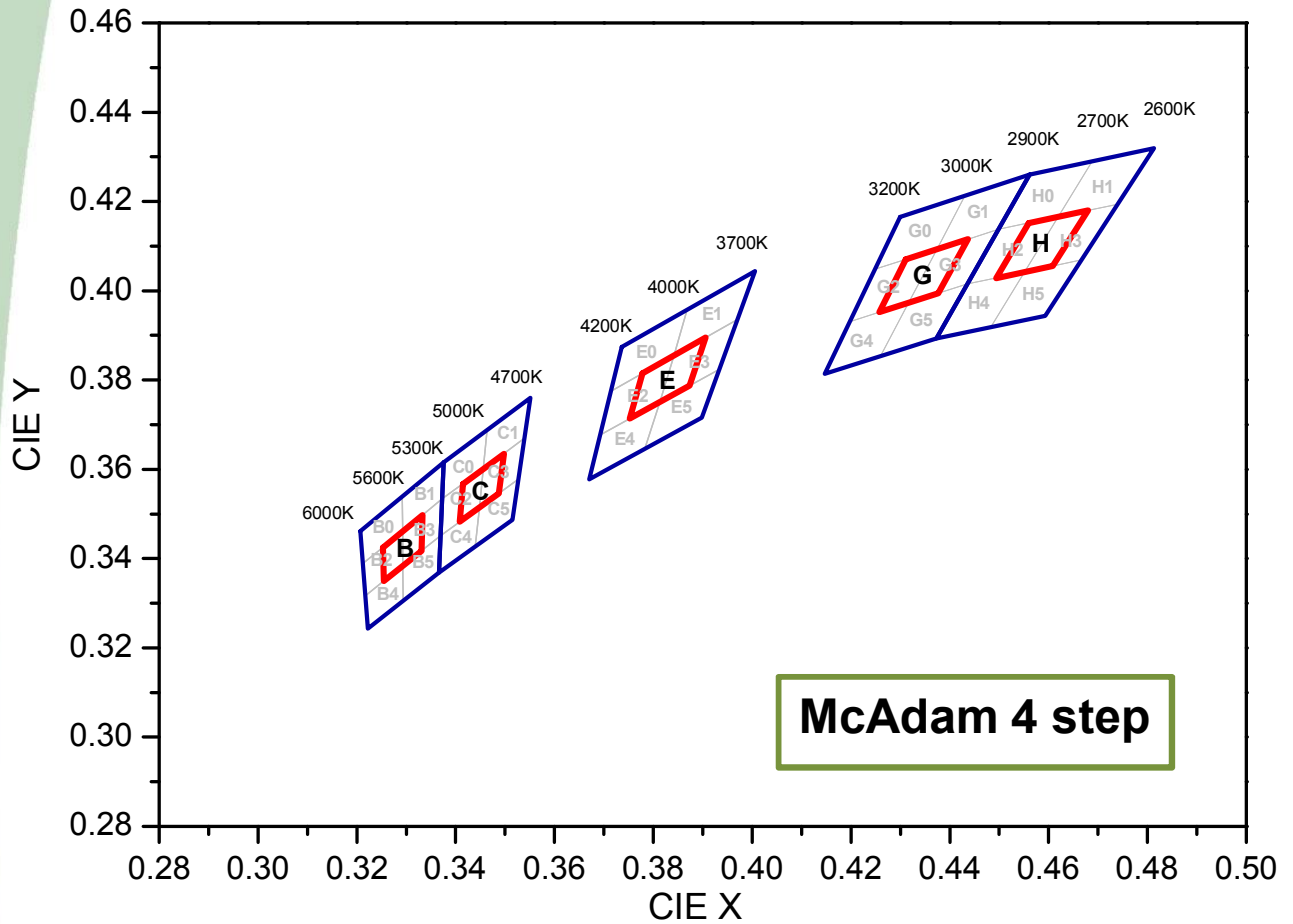

Bin code	X	Y	Bin code	X	Y	Bin code	X	Y
B	0.3253	0.3425	C	0.3415	0.3568	E	0.3778	0.3815
	0.3255	0.3350		0.3409	0.3483		0.3753	0.3714
	0.3331	0.3418		0.3487	0.3546		0.3874	0.3788
	0.3333	0.3498		0.3498	0.3635		0.3906	0.3895
G	0.4311	0.4071	H	0.4560	0.4152			
	0.4258	0.3952		0.4494	0.4029			
	0.4377	0.3994		0.4609	0.4056			
	0.4437	0.4116		0.4680	0.4180			

## 7. Marking

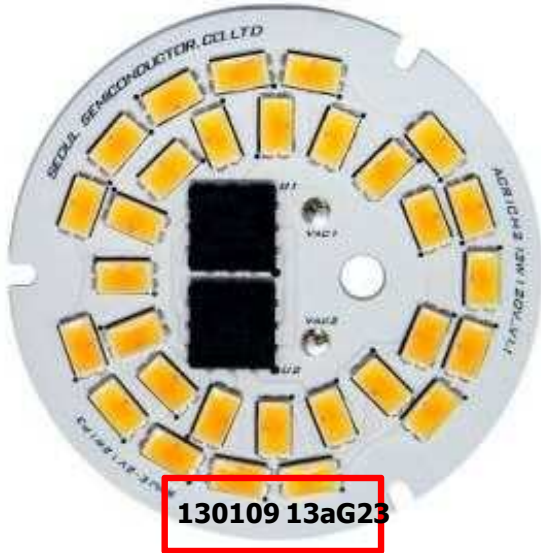

### • 13 Digits(including Blank)

130109 13a G 2 3  
 ①            ②    ③④⑤

- ① SMT Date(6 Digits) – ex)130109
- ② Flux(3 Digits)
- ③ CCT(1 Digit)
- ④ CCT Combination No.(1 Digit)
- ⑤ Vf Combination No.(1 Digit)

#### ② Flux

Marking	Flux[lm]		
	Min	Typ	Max
<b>13a</b>	880	1000	1140
<b>13b</b>	1140	1210	1300
<b>13c</b>	1300	1360	-

#### ③ CCT

Marking	CCT[K]		
	Min	Typ	Max
<b>B</b>	5300	5600	6000
<b>C</b>	4700	5000	5300
<b>E</b>	3700	4000	4200
<b>G</b>	2900	3000	3200
<b>H</b>	2600	2700	2900

#### ④ CCT Combination No.

Marking	Bin 1	Bin 2
<b>1</b>	0	5
<b>2</b>	5	0
<b>3</b>	1	4
<b>4</b>	4	1
<b>5</b>	2	3
<b>6</b>	3	2

#### ⑤ Vf Combination No.

Marking	Bin 1	Bin 2
<b>1</b>	A	A
<b>2</b>	A	B
<b>3</b>	B	A
<b>4</b>	A	C
<b>5</b>	C	A
<b>6</b>	B	B
<b>7</b>	B	C
<b>8</b>	C	B
<b>9</b>	C	C

### 8. Part List

No.	Part	Silk	Specification	Q'ty
1	PCB	-	Metal(AI) Φ50 1.6T	1
2	LED	-	SAW8KG0B	30
3	IC	U1,U2	MAH3082(120V) MAH3080(220V)	2

### 9. Outline dimensions

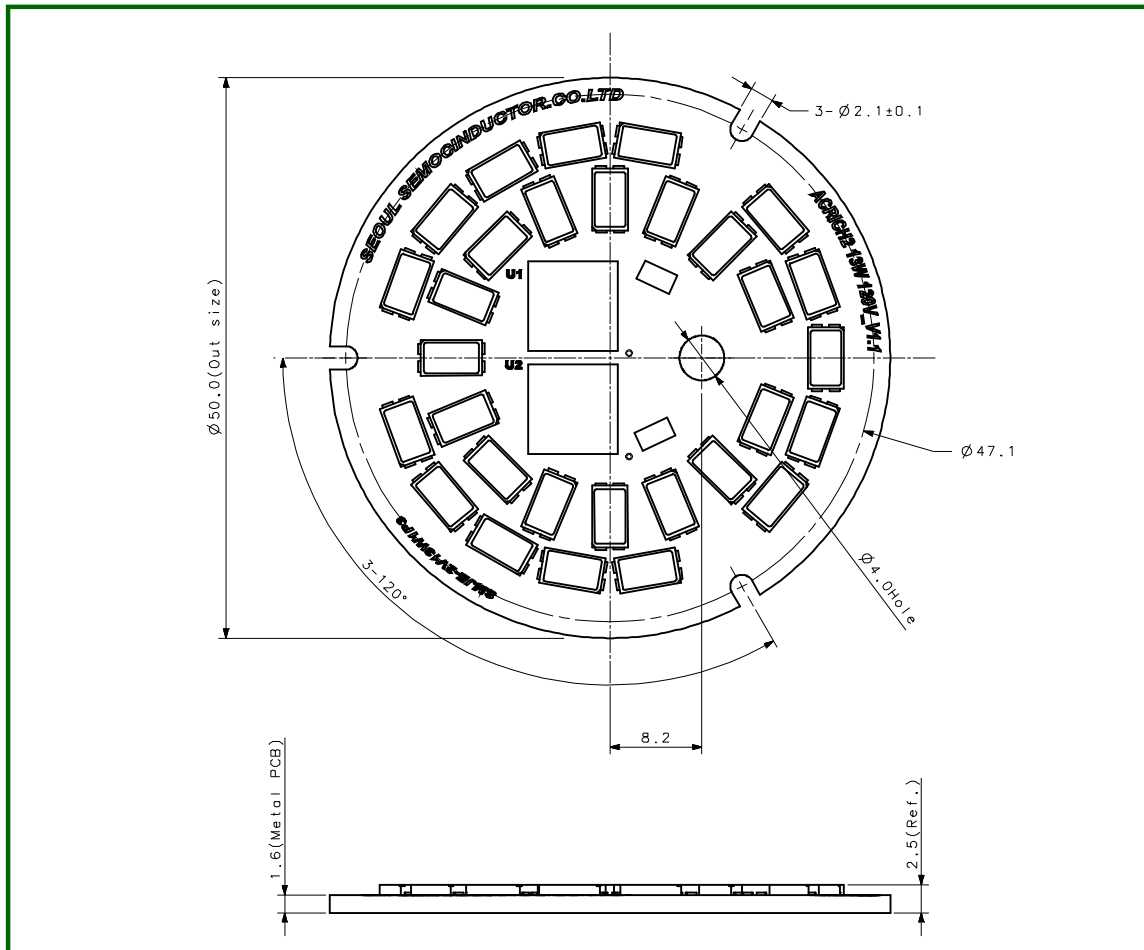

\* Notes :

[1] All dimensions are in millimeters. (Tolerance : ±0.2)

[2] Scale : none



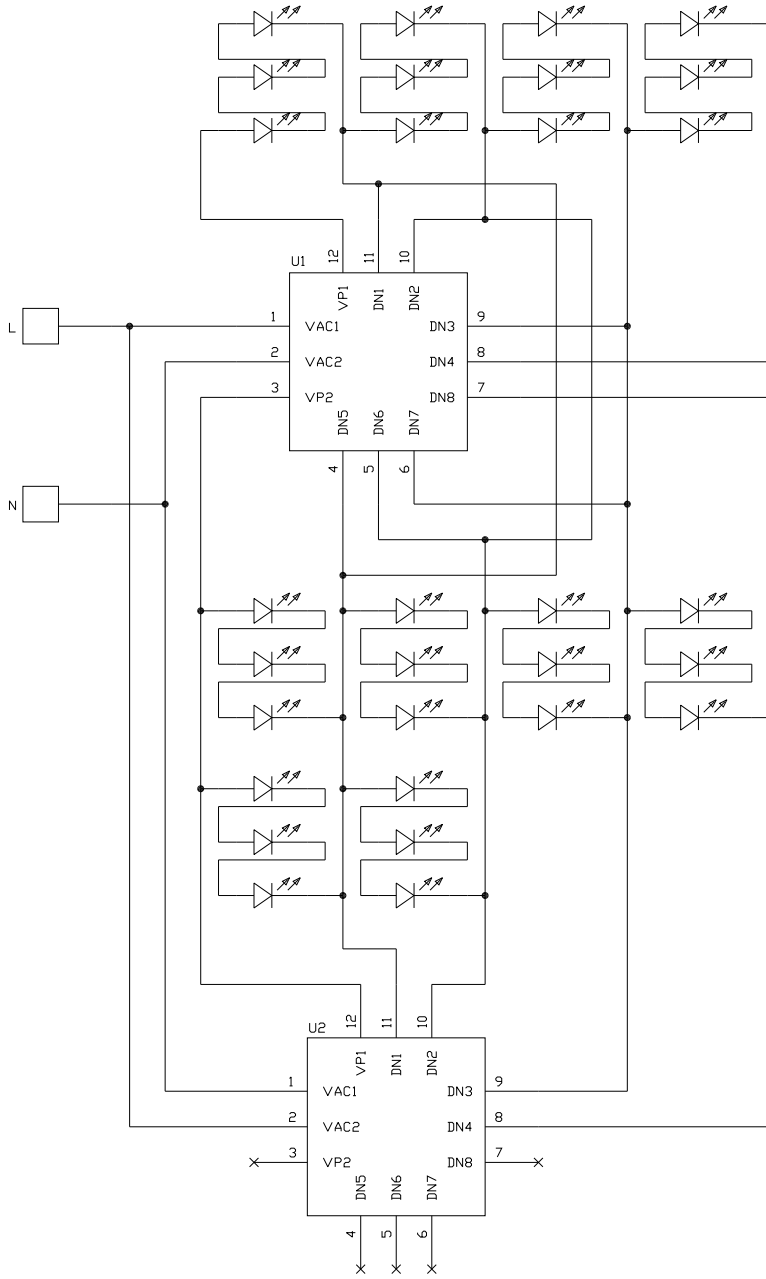

**SMJE-3V08W1P3 (220V)**

## 11. Packing

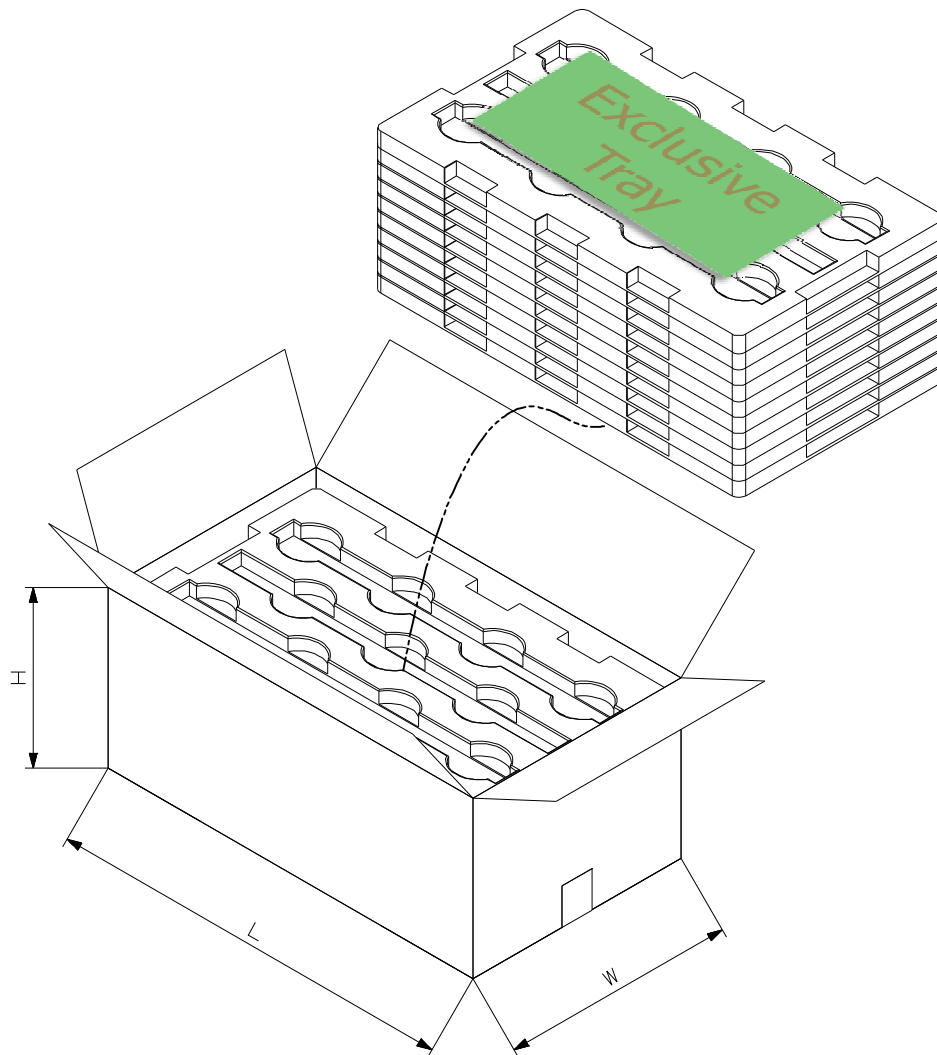

◦ **1Box : 50 PCS per tray x Max 8 layer = Max 400 PCS (about 6kg)**

◦ **Box size( L x W x H ) = 590 x 330 x 260**

## 12. Cautions for use

- Please review the Acrich2 Application Note for proper protective circuitry usage
- Please note, Acrich2 products run off of high voltage, therefore caution should be taken when working near Acrich2 products.
- DO NOT touch any of the circuit board, components or terminals with body or metal while circuit is active.
- Please do not add or change wires while Acrich2 circuit is active
- Long time exposure to sunlight or UV can cause the lens to discolor.
- Please do not use adhesives to attach the LED that outgas organic vapor.
- Please do not use together with the materials containing Sulfur.
- Please do not assemble in conditions of high moisture and/or oxidizing gas such as Cl, H<sub>2</sub>S, NH<sub>3</sub>, SO<sub>2</sub>, NO<sub>x</sub>, etc.
- Please do not make any modification on module.
- Please be cautious when soldering to board so as not to create a short between different trace patterns.

## 13. Handling of silicone resin for LEDs

- Acrich2 series is encapsulated with silicone resin for high optical efficiency.
- Please do not touch the silicone resin area with sharp objects such as pincette(tweezers).
- Finger prints on silicone resin area may affect the performance.
- Please store LEDs in covered containers to prevent dust accumulation as this may affect performance.
- Excessive force more than 3000gf to the silicone lens can result in fatal or permanent damage with LEDs.
- Please do not cover the silicone resin area with any other resins such as epoxy, urethane, etc.

## 14. Handling with regards to static electricity

- The Acrich2 products use an integrated circuit (IC) which can be damaged when exposed to static electricity. Please handle using equipment that prevents static electricity. Do not touch unless ESD protection is used.
- The Acrich2 product should also not be installed in end equipment without ESD protection.

## 15. Storage before use

- Do not impact or place pressure on this product because even a small amount of pressure can damage the product. The product should also not be placed in high temperatures, high humidity or direct sunlight since the device is sensitive to these conditions.
- When storing devices for a long period of time before usage, please following these guidelines:
  - \* The devices should be stored in the anti-static bag that it was shipped in from Seoul-Semiconductor with opening.
  - \* If the anti-static bag has been opened, re-seal preventing air and moisture from being present in the bag.

## 16. Guidelines for properly working with Acrich2

- Discharge the lighting system a minimum of 2-3 times prior to working with the module.
- Use only properly rated test equipment and tools for the rated voltage and current of the product being tested.
- It is strongly suggested to wear rubber insulated gloves and rubber bottom shoes.
- Do not wear any conductive items (such as jewelry) which could accidentally contact electric circuits.
- Perform several tests with power off and the lighting system unplugged.
- Faults, lightning, or switching transients can cause voltage surges in excess of the normal ratings.
- Internal component failure can cause excessive voltages.
- Stored or residual electricity in long wire could be hazardous.
- Make sure proper discharge prior to starting work.