

Specification

Acrich2 - 16W

SMJD-2V16W2P4 (120V)

SMJD-3V16W2P4 (220V)

SSC Development			SSC QC	Customer
Drawn	Checked	Approval	Approval	Approval

Acrich2 - 16W

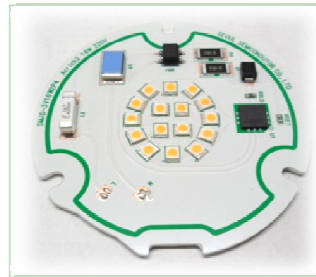

Description

The Acrich2 series of products are designed to be driven directly off of AC line voltage, therefore they do not need the standard converter essential for conventional general lighting products.

The converter or driver found in most general lighting products can limit the overall life of the product, but with the Acrich2 series of products the life of the product can more closely be estimated from the LED itself.

This will also allow for a much smaller form factor from an overall fixture design allowing for higher creativity in the fixture.

The modules have a high power factor which can contribute to a higher energy savings in the end application.

Acrich2

Features

- Connect using a AIC directly to AC power
- High Power Efficiency
- High Power Factor
- Low THD
- Long Life Time
- Simplest BOM
- Miniaturization
- Lead Free product
- RoHS compliant

Applications

- Down light

[Contents]

- 1. Characteristics**
- 2. Thermal Resistance**
- 3. Color spectrum**
- 4. Power characteristics**
- 5. Radiation pattern**
- 6. Binning Structure**
- 7. Marking**
- 8. Part List**
- 9. Outline dimensions**
- 10. Circuit Drawing**
- 11. Packing**
- 12. Box labeling**
- 13. Cautions for use**
- 14. Handling of silicone resin for LEDs**
- 15. Handling with regards to static electricity**
- 16. Storage before use**
- 17. Guidelines for properly working with Acrich2**

1. Characteristics

1-1. Electro-Optical characteristics of Acrich2 16W

Parameter	Symbol	Mark	Value			Unit
			Min	Typ	Max	
Luminous Flux [2]	Φ_V [3]	-	1070	1260		lm
Correlated Color Temperature [4]	CCT	B	5300	5600	6000	K
		C	4700	5000	5300	
		G	2900	3000	3200	
		H	2600	2700	2900	
CRI	R_a		80	-	-	-
Operating Voltage [5]	V_{opt}			120		V[RMS]
				220		
Power Dissipation	P_D		15.3	16	16.7	W
Operating Frequency	Freq			50 / 60		Hz
Power Factor	PF			Over 0.97		-
View Angle	2θ 1/2			120		deg.
Tolerance of Surge [6]	V_s		500	-	-	V

1-2. Absolute Maximum Ratings

Parameter	Symbol	Raged Voltage	Value	Unit
Max. Voltage	V_{opt}	120V	140	V[RMS]
		220V	264	
Power Dissipation	P_d		23	W
Operating Temperature	T_{opr}		-30 ~ 85	°C
Storage Temperature	T_{stg}		-40 ~ 100	°C
ESD Sensitivity	-		±4,000V HBM	-

*** Notes :**

- [1] At 120V and 220V RMS, Ta=25℃
- [2] Acrich2 series maintain the tolerance of ±10% on flux and power measurements.
- [3] Φ_v is the total luminous flux output measured with an integrated sphere.
- [4] Correlated Color Temperature is derived from the CIE 1931 Chromaticity diagram.
- [5] Operating Voltage doesn't indicate the maximum voltage which customers use but means tolerable voltage according to each country's voltage variation rate.
It is recommended that the solder pad temperature should be below 70℃.
- [6] It means surge voltage of product that can withstand. Surge value followed by the standard of IEC61000-4-5.

2. Thermal Resistance

Part	Package Power Dissipation [W]	Maximum Junction Temp[°C]	R θ_{j-s} [°C/W]
Acrich2 LED	SAW8WA2A Max 1.55	125	23
Acrich2 IC	Max 1.0	150	11.25

The Acrich2 LED has a thermal resistance of 23 °C/W from junction of the LED to the LED lead.

The maximum junction temperature of the Acrich2 LED package is 125 °C, therefore the maximum lead temperature T_{s_max} is

$$T_{s_max} = T_{j_max} - (R\theta_{j-s} * P_D)$$

$$= 125^\circ\text{C} - (23^\circ\text{C/W} * 1.55\text{W}) = 89.35^\circ\text{C}$$

Although this is the maximum lead temperature, it is recommended to keep the lead temperature under 70 °C

The Acrich2 IC has a 16.4degC/W thermal resistance from junction to the top surface.

The maximum junction temperature (T_{t_max}) of the IC is 125 °C, therefore the maximum temperature of the top of the IC is

$$T_{t_max} = T_{j_max} - (\psi_{j-t} * P_D)$$

$$= 125^\circ\text{C} - (11.25^\circ\text{C/W} * 1.0\text{W}) = 138.75^\circ\text{C}$$

3. Color spectrum

Relative Spectral Power Distribution at Ta=25°C –G, H

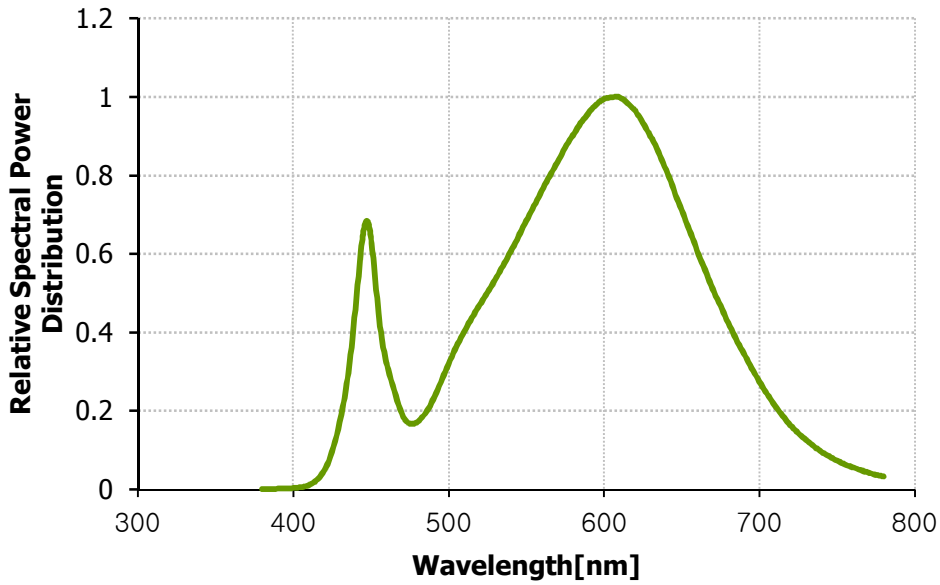

Relative Spectral Power Distribution at Ta=25°C - B, C

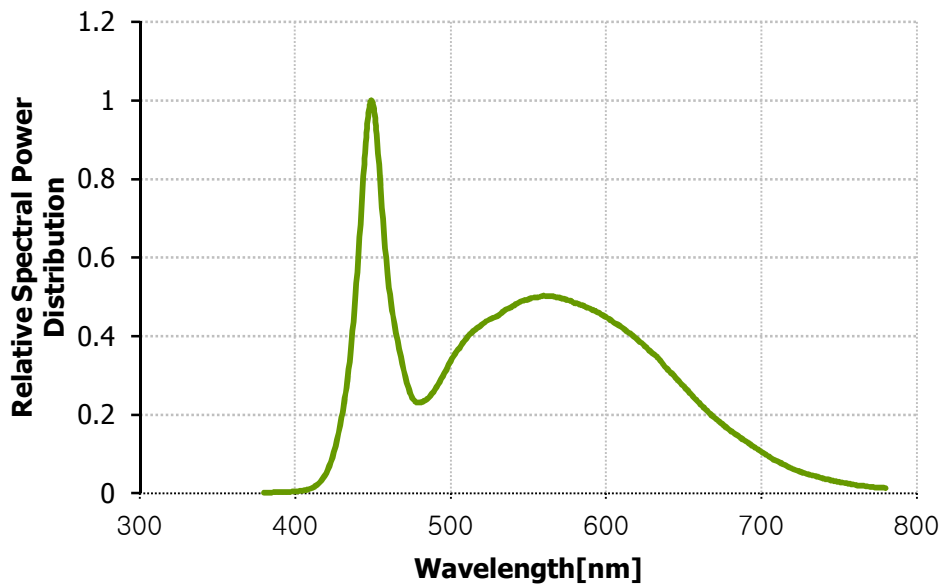

4. Power characteristic

Relative Power Distribution vs. Voltage at Ta=25°C

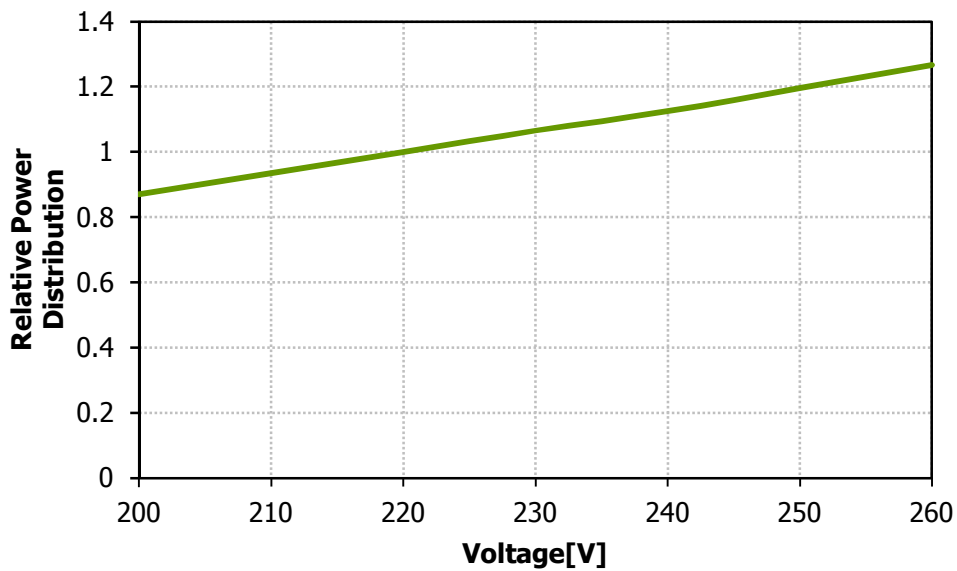
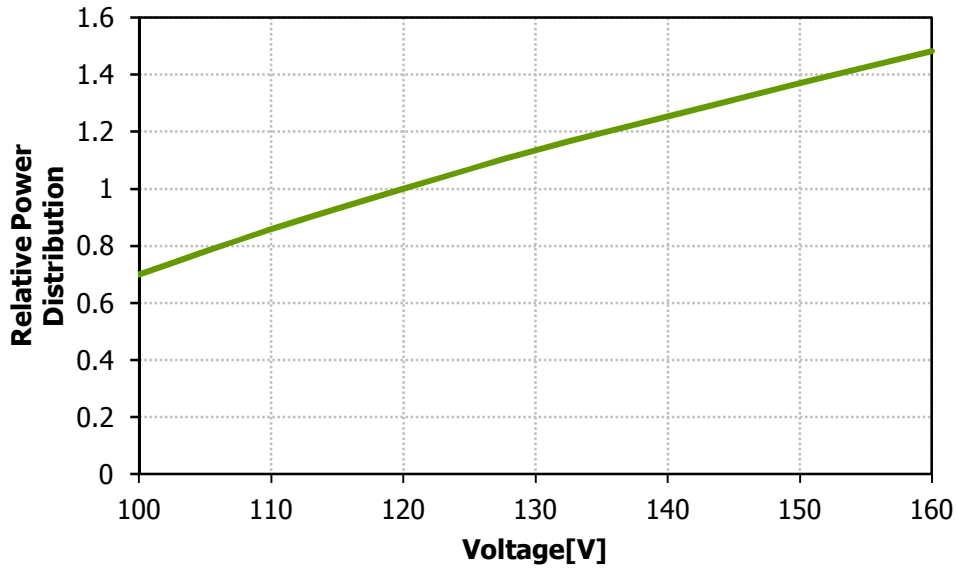

Relative Luminous flux vs. Forward Voltage, Ta=25°C

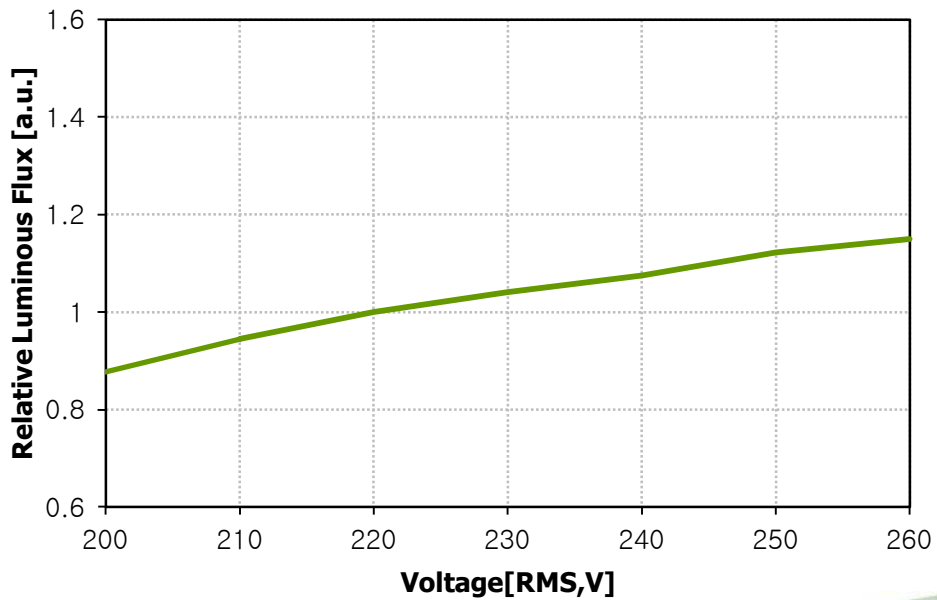
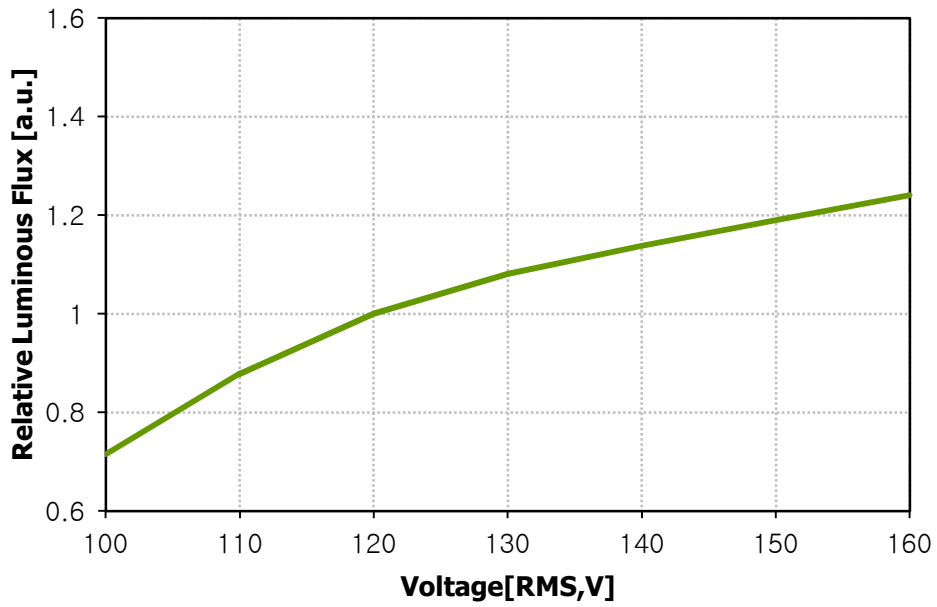

5. Radiation Pattern

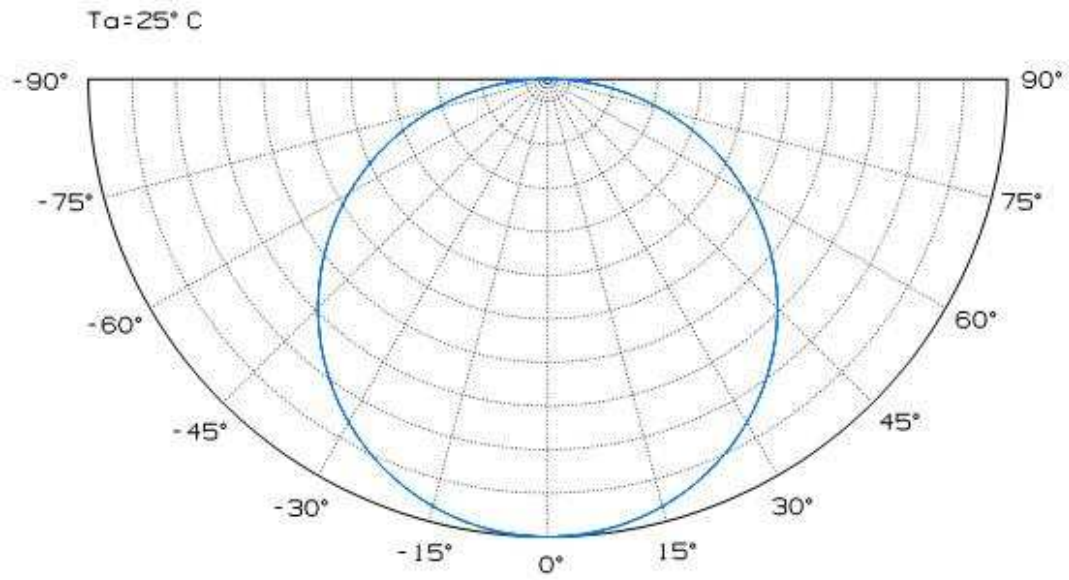

6. Color & Binning

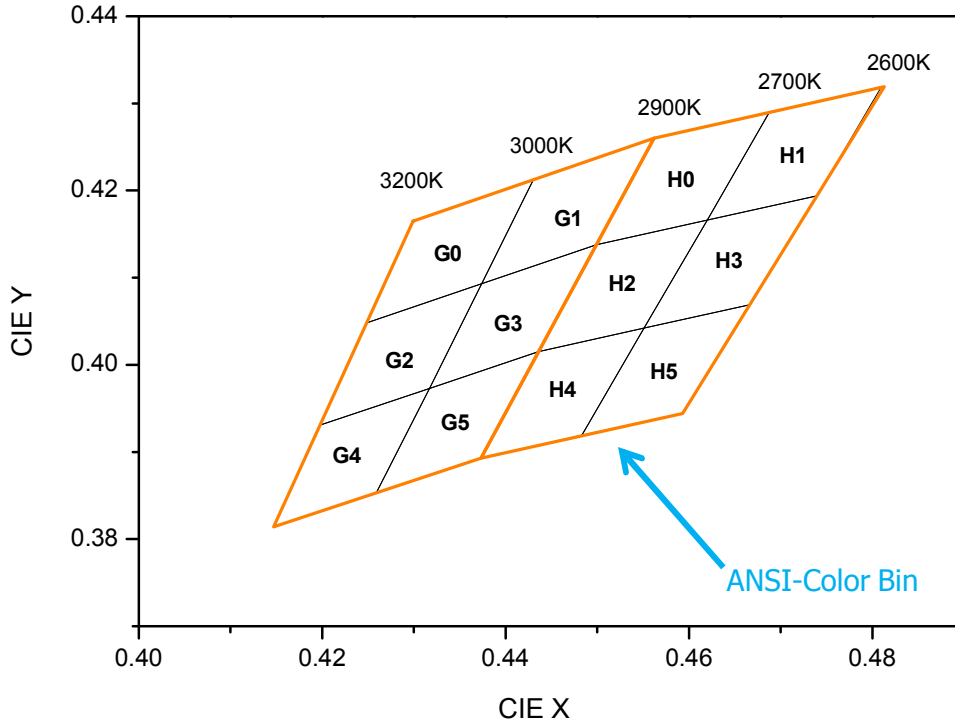

▷ COLOR RANK

Bin code	X	Y	Bin code	X	Y	Bin code	X	Y
G0	0.4299	0.4165	G1	0.4430	0.4212	G2	0.4248	0.4048
	0.4248	0.4048		0.4374	0.4093		0.4198	0.3931
	0.4374	0.4093		0.4499	0.4138		0.4317	0.3973
	0.4430	0.4212		0.4562	0.4260		0.4374	0.4093
G3	0.4374	0.4093	G4	0.4198	0.3931	G5	0.4317	0.3973
	0.4317	0.3973		0.4147	0.3814		0.4259	0.3853
	0.4436	0.4015		0.4259	0.3853		0.4373	0.3893
	0.4499	0.4138		0.4317	0.3973		0.4436	0.4015
H0	0.4562	0.4260	H1	0.4687	0.4289	H2	0.4499	0.4138
	0.4499	0.4138		0.4620	0.4166		0.4436	0.4015
	0.4620	0.4166		0.4740	0.4194		0.4551	0.4042
	0.4687	0.4289		0.4810	0.4319		0.4620	0.4166
H3	0.4620	0.4166	H4	0.4436	0.4015	H5	0.4551	0.4042
	0.4551	0.4042		0.4373	0.3893		0.4483	0.3919
	0.4666	0.4069		0.4483	0.3919		0.4593	0.3944
	0.4740	0.4194		0.4551	0.4042		0.4666	0.4069

* Measurement Uncertainty of the Color Coordinates : ± 0.01

Rev. 00

APRIL 2013

www.Acrich.com

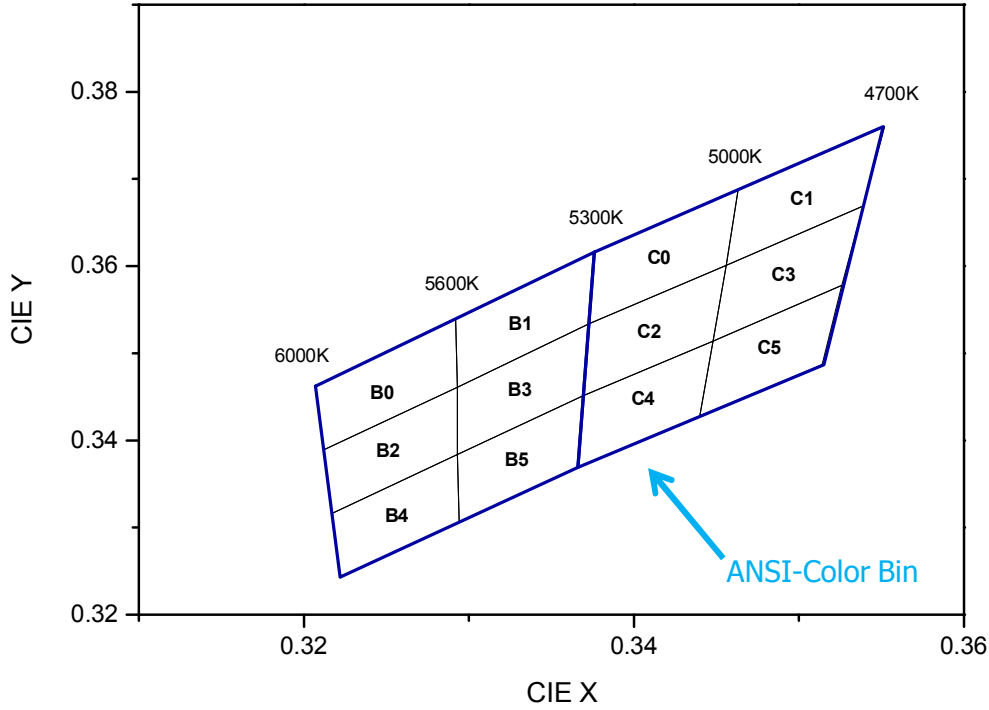

▷ **COLOR RANK**

Bin code	X	Y	Bin code	X	Y	Bin code	X	Y
B0	0.3207	0.3462	B1	0.3292	0.3539	B2	0.3212	0.3389
	0.3212	0.3389		0.3293	0.3461		0.3217	0.3316
	0.3293	0.3461		0.3373	0.3534		0.3293	0.3384
	0.3292	0.3539		0.3376	0.3616		0.3293	0.3461
B3	0.3293	0.3461	B4	0.3217	0.3316	B5	0.3293	0.3384
	0.3293	0.3384		0.3222	0.3243		0.3294	0.3306
	0.3369	0.3451		0.3294	0.3306		0.3366	0.3369
	0.3373	0.3534		0.3293	0.3384		0.3369	0.3451
C0	0.3376	0.3616	C1	0.3463	0.3687	C2	0.3373	0.3534
	0.3373	0.3534		0.3456	0.3601		0.3369	0.3451
	0.3456	0.3601		0.3539	0.3669		0.3448	0.3514
	0.3463	0.3687		0.3552	0.3760		0.3456	0.3601
C3	0.3456	0.3601	C4	0.3369	0.3451	C5	0.3448	0.3514
	0.3448	0.3514		0.3366	0.3369		0.3440	0.3428
	0.3526	0.3578		0.3440	0.3428		0.3514	0.3487
	0.3539	0.3669		0.3448	0.3514		0.3526	0.3578

* Measurement Uncertainty of the Color Coordinates : ± 0.01

7. Marking

XX00 : CCT
- H rank : 2700
- G rank : 3000
- C rank : 5000
- B rank : 5600

XXXXXX : (Production date) Year/Month/date

aaa : LED PKG Flux rank

bb : Color bin

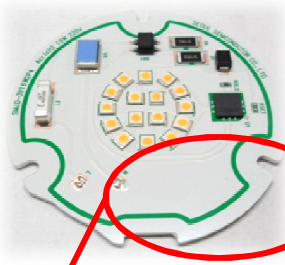

8. Part list

NO.	Item	Silk	Specification	Unit	Q'ty
1	LED	-	SAW8WA2A	EA	16
2	IC	IC	DT3001B	EA	1
3	Resistor	Rbld	1608size 1K Ohm 1%	EA	1
4	Resistor	Rset	1608size 3.6K Ohm 1% (120V)	EA	1
			1608size 1.6K Ohm 1% (220V)		
5	Resistor	R1, R2	6432size 91 Ohm 5%	EA	2
6	TVS	T1	P6SMB440A 440Vdc	EA	1
7	Bridge Diode	BD1	MB6S 600V 1A	EA	1
8	Fuse	F1	443 series 250V 1A	EA	1
9	Varistor	VR1	8S17SM251S 250Vac/330Vdc	EA	1
10	Metal PCB	-	AL5052, Ø62, 1.6t	EA	1

9. Outline dimensions

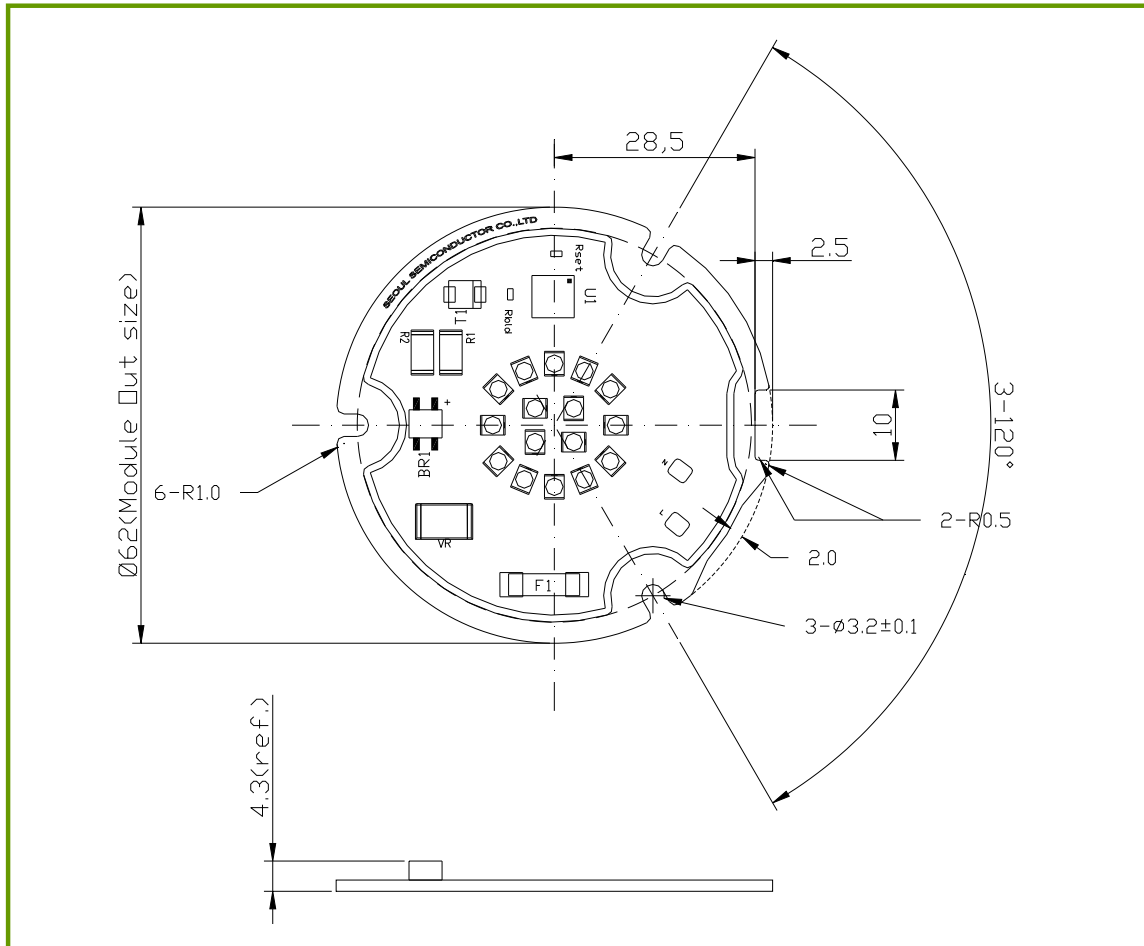

* Notes :

[1] All dimensions are in millimeters. (Tolerance : ± 0.2)

[2] Scale : none

10. Circuit Drawing

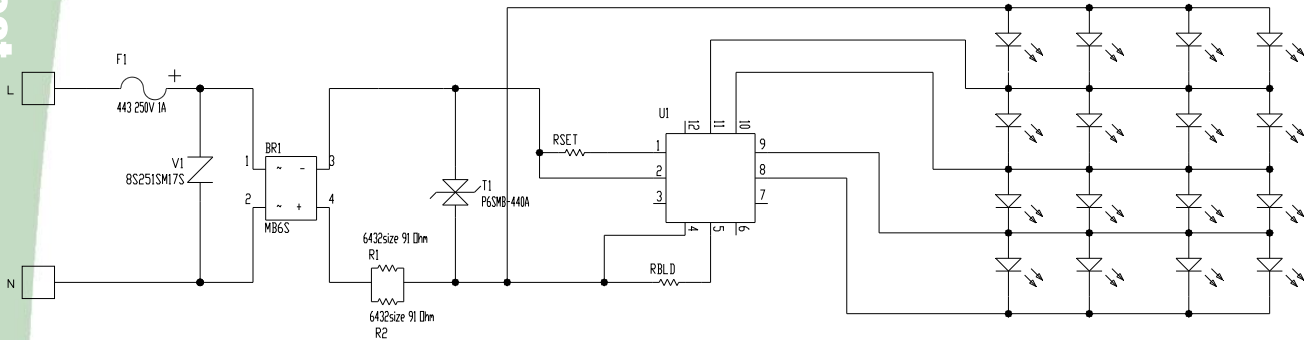

SMJD-2V16W2P4 (120V)

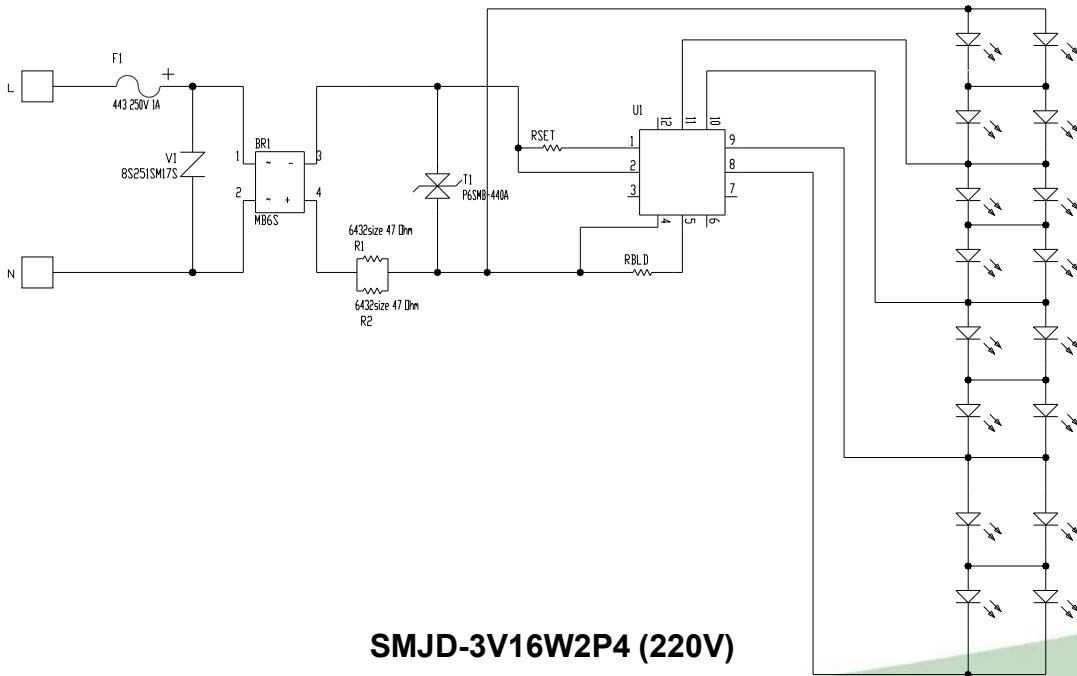

SMJD-3V16W2P4 (220V)

11. Packing

1. Tray information

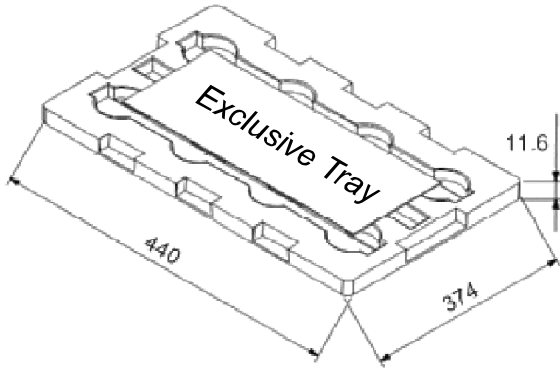

- 15pcs LED module packed per tray

2. Tray stack and taping

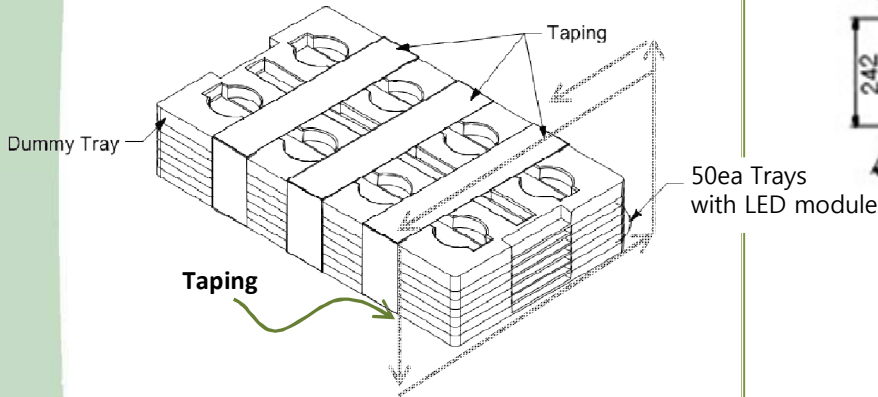

- 12 LED module trays and additional 2 dummy trays up and down (2 EA) of box
- Add silica gel (1 EA) on top of the tray

3. Sealing packing

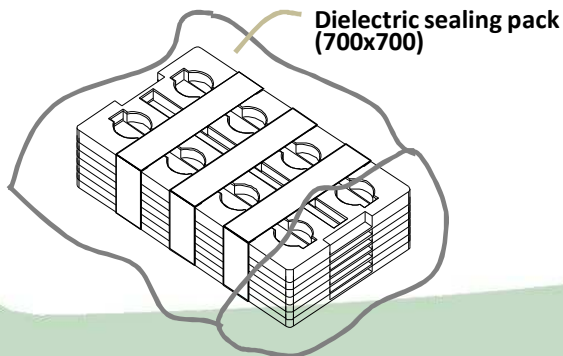

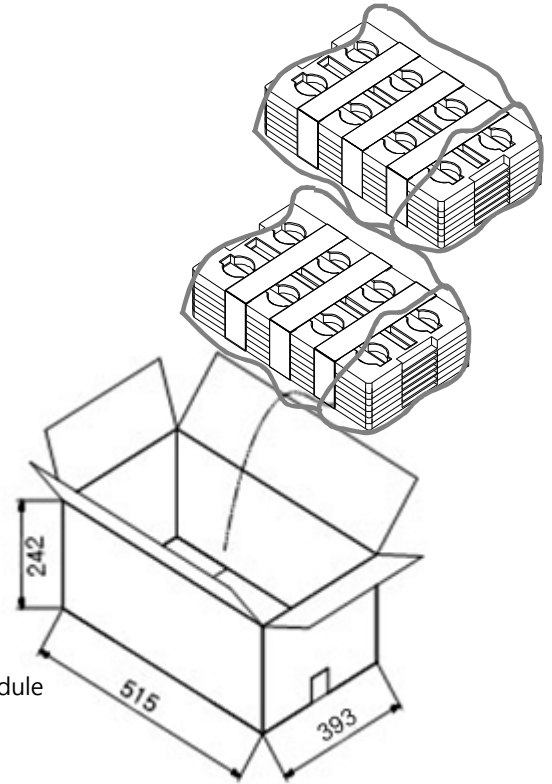

4. Box information & packing



- 300 EA module per BOX 1EA



** 1Box : 15 PCS per tray x 20 tray = 300ea
about 5kg

12. Box labeling

Model No.	SMJD-XV16W2P4 ¹⁾
Rank	 XXXXX ²⁾
Type	
Quantity	 XX
Date	YYYY.MM.DD
	SEOUL SEMICONDUCTOR CO.,LTD.

Note.

- 1) The model Number designation is explained as follow
 SMJD-XV16W2P4
 Where
 SMJE : SSC internal code
 XV : Operating Voltage (2V = 120V / 3V = 220V)
 16W : About Power Consumption
 2 : Acrich IC Version
 P4: MJT PKG (SAW8WA2A)
- 2) It represents the LED PKG rank that consists of five characters.
- 3) It is attached to the top left corner of the box.

<p>TOTAL Quantity</p>  <p>XX</p>	
	SEOUL SEMICONDUCTOR CO.,LTD.

Note.

- 1) It is attached to the bottom right corner of the box

13. Usage precautions

- Please review the Acrich2 Module Application Note for protective circuitry component usage.
- Please note, the Acrich products run on high voltage so use caution when near the the device which the circuit is active.
- DO NOT touch any of the circuit board, components or terminals with body or metal while circuit is active.
- Please do not add or change wires while Acrich circuit is active
- Long time exposure of sunlight or occasional UV exposure will cause lens discoloration.
- Please do not use adhesives to attach the LED that outgas organic vapor.
- Please do not use together with the materials containing Sulfur
- Please do not assemble under the condition of moisture and oxidizing gas in the air(Cl, H₂S, NH₃, SO₂, NOX, etc)
- Please do not make any modification on module.
- Please be cautious as soldering in order to avoid short between different patterns.

14. Handling of silicone resin for LEDs

- Acrich series is encapsulated with silicone resin for high optical efficiency.
- Please do not touch the silicone resin area with sharp objects such as pincette(tweezers).
- Finger prints on silicone resin area may affect the performance.
- Please store LEDs in covered containers as it is dust sensitive.
- Excessive force more than 3000gf to the silicone lens can result in fatal or permanent damage with LEDs.
- Please do not cover the silicone resin area with any other resins such as epoxy, urethane, etc.

15. Handling with regards to static electricity

- The Acrich2 modules use an integrated circuit (IC) which can be damaged when exposed to static electricity. Please handle using equipment that prevents static electricity. Do not touch unless ESD protection is used.
- The Acrich2 modules should also not be installed in end equipment with out ESD protection.

16. Storage before use

- Do not impact or place pressure on this product because even a small amount of pressure can damage the product. The product should also not be placed in high temperatures, high humidity or direct sunlight since the device is sensitive to these conditions.

(1) Please, confirm the lists below, when storing it in a long term.

- * It should be stored in the anti-static bag that Seoul-Semiconductor packed without opening it.
- * If you opened it in order to prevent humidity, you should seal it and not let the air and humidity into the bag.

17. Guidelines for Acrich module work

- Discharge the lighting system minimum 2~3 times prior to starting work.
- Use only the tested instruments, and insulated tools rated for the voltage and current specified.
- Wear rubber made gloves and rubber bottom shoes or sneakers.
- Do not wear any conductive items (such as jewelry) which could accidentally contact electric circuits.
- Perform several tests with power off and the lighting system unplugged.
- Faults, lightning, or switching transients can cause voltage surges in excess of the normal ratings.
- Internal component failure can cause excessive voltages.
- Stored or residual electricity in long wire could be hazardous. Make sure proper discharge prior to starting work.