

Specifications

Specifications	Units	PTM-12K	PTM-12KGH (gearhead)							
Rated Voltage	V	12/24/100/117/220/240 ±10%								
Frequency	Hz	50/60								
Rated Current	mA	18/17								
Revolutions @ 50Hz	rpm	500/600	1	2	4	5	6	10	15	20
Rotating Direction		Single Direction (CC/CCW)								
Torque @ 60 Hz	mN·m	1.0/0.9	200	150	120	100	80	50	32	25
Temperature Rise	°K	35								
Operating Temp. Range	°C	-10 to +50								
Dielectric Strength	V	1500Vac for 10 seconds	1500Vac for 10 seconds							
Weight	g	90	120							
Capacitor	µF	--								

Magnet type: Anisotropic

Torque Characteristics

Model	PTM-12KG		
Speed	Torque	Gear Ratio	
rpm	mN·m	50Hz	60Hz
20	25	1/25	1/30
10	50	1/50	1/60
6	80	3/250	1/100
5	100	1/100	1/120
4	120	1/125	1/150
2	150	1/250	1/300
1	200	1/500	1/600

Geared Models

PTM-12KG

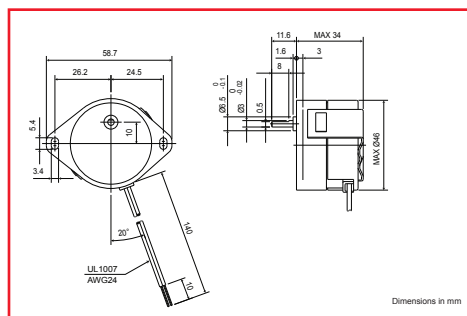

Single Direction Synchronous Motors

PTM - 24 B (GII) 100 - 50/60- 2/2.4 CW

1 2 3 4 5 6 7 8 9

1 - Series Designation

PTM: Flying lead joint

2 - Number of Poles

12: Speed is 500rpm w/50Hz

Speed is 600rpm w/60Hz

24: Speed is 250rpm w/50Hz

Speed is 300rpm w/60Hz

3 - Outer Diameter

B: 35mm

K: 42mm

E: 42mm (high output torque)

4 - Gear Head

Blank: No gear head

G: Gear head intergrated

5 - PTM-24BGII only

Denotes BG gear type II

6 - Supply Voltage

24, 100, 200 Vac
voltage depends on model

7 - Power Frequency

50, 60, or 50/60Hz

8 - Rotating Speed

Line frequency of 60Hz
makes the motor speed
1.2 times higher than
50Hz

9 - Direction

CW - Clockwise

CCW - Counterclockwise

Gear Ratio	rpm w/12 poles		rpm w/24 poles	
	50Hz	60Hz	50Hz	60 Hz
Motor only	500	600	250	300
1/10	50	60	25	30
1/50	10	12	5	6
1/100	5	6	2.5	3

Single Direction Synchronous Motor

Motors that are driven in just one direction, whether clockwise or counterclockwise, do not require any specific wiring to the AC power supply. A wiring diagram is below. The leadwires have no polarity.

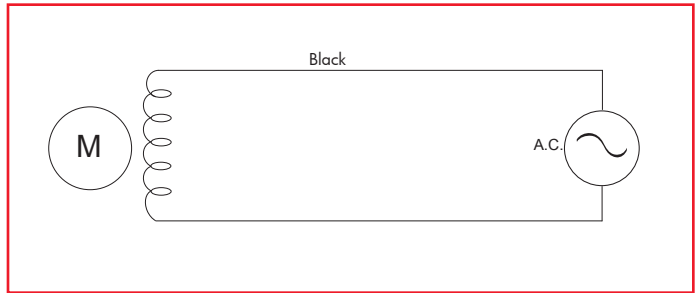

About Nippon Pulse Synchronous Motors

No Power or Load Fluctuation Effect

Synchronous motors rotate in synch with supplied power frequency. If power frequency is constant, the motor will rotate at a constant speed (synchronized speed).

Impedance Protected

Unless otherwise stated, these motors provide high electrical resistance, which prevents overcurrent from flowing to the motor, which would in turn burn the coils.

No Control Circuit Required

Because these motors are AC motors, they start rotating when a power connection is made.

Excellent Response

The type of magnet used in these motors ensures excellent response and also ensures the motor will start and stop immediately when power is supplied or removed.