

TO SNAP-LOCK IN A $.156 \pm .003$
(4.00 ± 0.08) DIA. HOLE, IN A
.062 (1.57) THICK BOARD

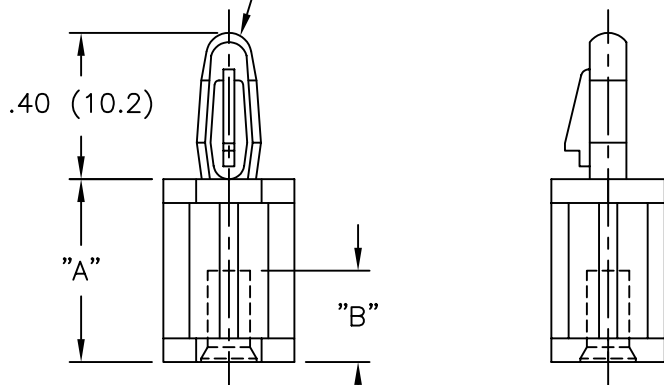

FOR #6 (M3.5)
SELF-TAPPING
SCREW (TYPE B)

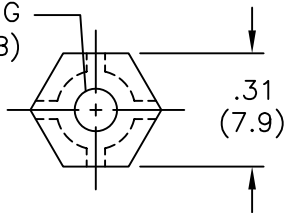

NYLON 6/6 (RMS-01) COLOR: NATURAL PART NO.	FLAME RET. (RMS-19) COLOR: NATURAL PART NO.	DIM "A" $\pm .015$ (± 0.4)	DIM "B" $\pm .015$ (± 0.4)
TCBS-4-01	TCBS-4-19	1/4 (6.4)	13/64 (5.2)
TCBS-6-01	TCBS-6-19	3/8 (9.5)	5/16 (7.9)
TCBS-8-01	TCBS-8-19	1/2 (12.7)	
TCBS-10-01	TCBS-10-19	5/8 (15.9)	
TCBS-12-01	TCBS-12-19	3/4 (19.1)	
TCBS-14-01	TCBS-14-19	7/8 (22.2)	
TCBS-16-01	TCBS-16-19	1 (25.4)	
TCBS-18-01	TCBS-18-19	1-1/8 (28.6)	
TCBS-20-01	TCBS-20-19	1-1/4 (31.7)	
TCBS-22.5-01	TCBS-22.5-19	1-13/32 (35.7)	

TITLE: SCREW-MOUNT CIRCUIT BOARD SUPPORT						DWG IN IN (MM)	
TOLERANCES UNLESS NOTED .XX= $\pm .010$.XXX= $\pm .005$ FRAC= $\pm 1/64$ ANG= $\pm 1^\circ$	FILE # TCBS	DWN: P.B.	APP:	FINAL			
	MAT'L: SEE NOTES	DT: 01-23-95	DT:	PART #		PRINT	
	RE: RICHCO INC.	RICHCO INC. PO BOX 804238, CHICAGO, 60680 (773) 539-4060		SEE TABLE		TYPE CA	

B	REMOVED NOTES. AND CHANGED FILE NO.	SM 04.19.02
A	CONVERTED TO ACAD	PB 01.23.95
REV	DESCRIPTION	ENGR DATE