

TMS320C5502 eZdspTM ***Development Kit***

*Technical
Reference*

TMS320C5502 eZdsp™
Development Kit
Technical Reference

514325-0001 Rev. A
October 2011

SPECTRUM DIGITAL, INC.
12502 Exchange Drive, Suite 440 Stafford, TX. 77477
Tel: 281.494.4505 Fax: 281.494.5310
sales@spectrumdigital.com www.spectrumdigital.com

IMPORTANT NOTICE

Spectrum Digital, Inc. reserves the right to make changes to its products or to discontinue any product or service without notice. Customers are advised to obtain the latest version of relevant information to verify that the data being relied on is current before placing orders.

Spectrum Digital, Inc. warrants performance of its products and related software to current specifications in accordance with Spectrum Digital's standard warranty. Testing and other quality control techniques are utilized to the extent deemed necessary to support this warranty.

Please be aware that the products described herein are not intended for use in life-support appliances, devices, or systems. Spectrum Digital does not warrant nor is Spectrum Digital liable for the product described herein to be used in other than a development environment.

Spectrum Digital, Inc. assumes no liability for applications assistance, customer product design, software performance, or infringement of patents or services described herein. Nor does Spectrum Digital warrant or represent any license, either express or implied, is granted under any patent right, copyright, or other intellectual property right of Spectrum Digital, Inc. covering or relating to any combination, machine, or process in which such Digital Signal Processing development products or services might be or are used.

WARNING

This equipment is intended for use in a laboratory test environment only. It generates, uses, and can radiate radio frequency energy and has not been tested for compliance with the limits of computing devices pursuant to subpart J of part 15 of FCC rules, which are designed to provide reasonable protection against radio frequency interference. Operation of this equipment in other environments may cause interference with radio communications, in which case the user at his own expense will be required to take whatever measures necessary to correct this interference.

TRADEMARKS

Windows 2000, Windows XP, Windows Vista are registered trademarks of Microsoft Corp

Code Composer Studio IDE is a trademark of Texas Instruments

"eZdsp" is a trademark of Spectrum Digital, Inc.

Contents

1	Introduction to the TMS320C5502 eZdsp	1-1
	<i>Provides a description of the TMS320C5502 eZdsp, and key features.</i>	
1.0	Overview of the TMS320C5502 eZdsp	1-2
1.1	Key Features of the TMS320C5502 eZdsp	1-4
1.2	C5502 eZdsp Block Diagram	1-5
1.3	C5502 eZdsp Memory Map	1-6
1.4	C5502 eZdsp I ² C Addressing	1-7
1.4.1	I ² C Expander Definition	1-7
2	Operation and Physical Specifications	2-1
	<i>Describes the operation and physical layout of the TMS320C5502 eZdsp and its connectors.</i>	
2.0	Board Layout	2-2
2.1	Connector Index	2-4
2.1.1	J1, C5502 USB Connector	2-4
2.1.2	J2, XDS100v2 USB Connector	2-5
2.1.3	J3, Audio In Connector	2-6
2.1.4	J4, Audio Out Connector	2-7
2.1.5	J5, LCD Interface	2-8
2.1.6	J6, Micro SD Connector	2-9
2.1.7	P1, P2, TI Wireless Interface	2-10
2.1.6	P4, Expansion Connector	2-11
2.2	System LEDs	2-13
2.3	Switches	2-13
2.4	Test Points	2-14
A	Schematics	A-1
	<i>Contains the schematics for the TMS320C5502 eZdsp</i>	
B	Mechanical Information	B-1
	<i>Contains the mechanical information about the TMS320C5502 eZdsp</i>	

About This Manual

This document describes the board level operations of the TMS320C5502 eZdsp. The TMS320C5502 eZdsp is based on the Texas Instruments TMS320C5502 Digital Signal Processor.

The TMS320C5502 eZdsp multi-layer printed circuit board (PCB) that allows engineers and software developers to evaluate certain characteristics of the TMS320C5502 DSP.

Notational Conventions

This document uses the following conventions.

The TMS320C5502 eZdsp will sometimes be referred to as the or C5502 eZdsp, or eZdsp.

Program listings, program examples, and interactive displays are shown in a special italic typeface. Here is a sample program listing.

```
equations  
!rd = !strobe&rw;
```

Information About Cautions

This book may contain cautions.

This is an example of a caution statement.

A caution statement describes a situation that could potentially damage your software, or hardware, or other equipment. The information in a caution is provided for your protection. Please read each caution carefully.

Related Documents

Texas Instruments Code Composer Studio IDE Users Guide
Data sheet for the TMS320C5502

Chapter 1

Introduction to the TMS320C5502 eZdsp Development Kit

This chapter provides you with a description of the C5502 eZdsp along with the key features.

Topic	Page
1.0 Overview of the TMS320C5502 eZdsp	1-2
1.1 Key Features of the TMS320C5502 eZdsp	1-4
1.2 C5502 eZdsp Block Diagram	1-5
1.3 C5502 eZdsp Memory Map	1-6
1.4 C5502 eZdsp I ² C Addressing	1-7
1.4.1 I ² C Expander Definition	1-7

1.0 Overview of the C5502 eZdsp

The C5502 eZdsp is an evaluation tool for the Texas Instruments TMS320C5502 Digital Signal Processor (DSP). This USB bus powered tool allows the user to evaluate the following items:

- The TMS320C5502 processor along with its peripherals
- The TLV320AIC3204 codec
- The Code Composer Studio IDE™ software development tools

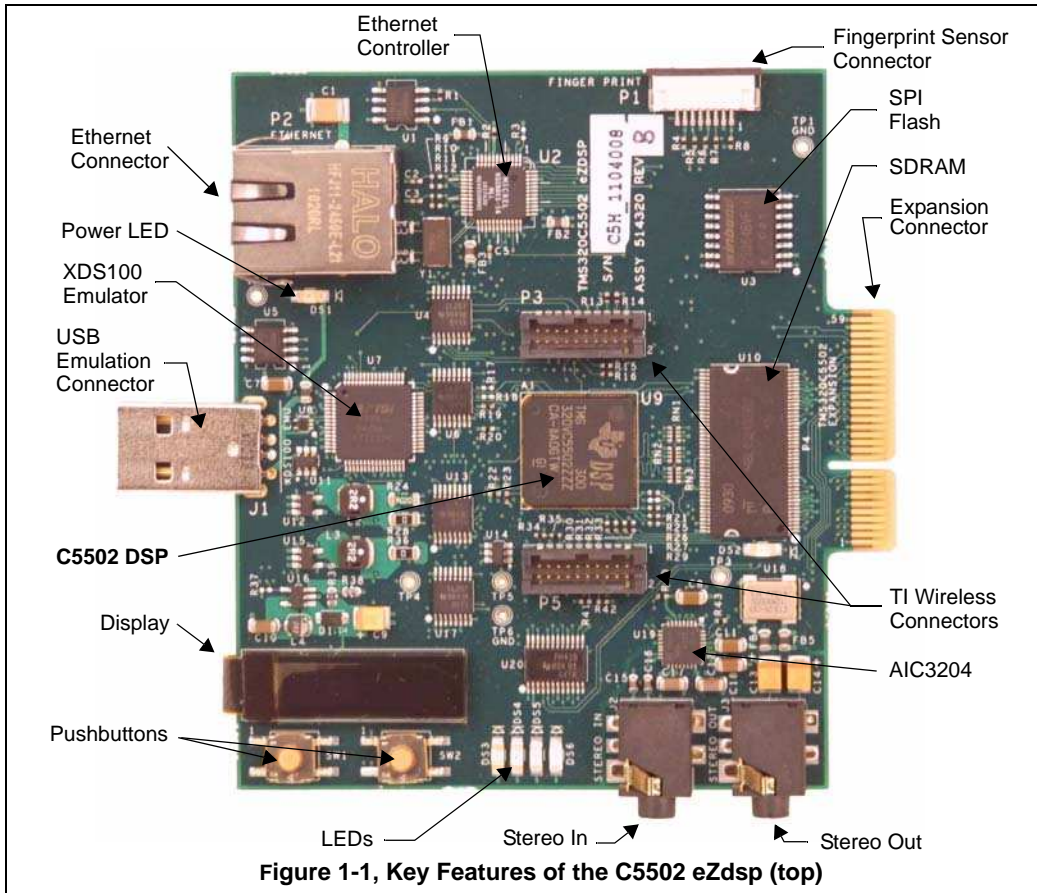

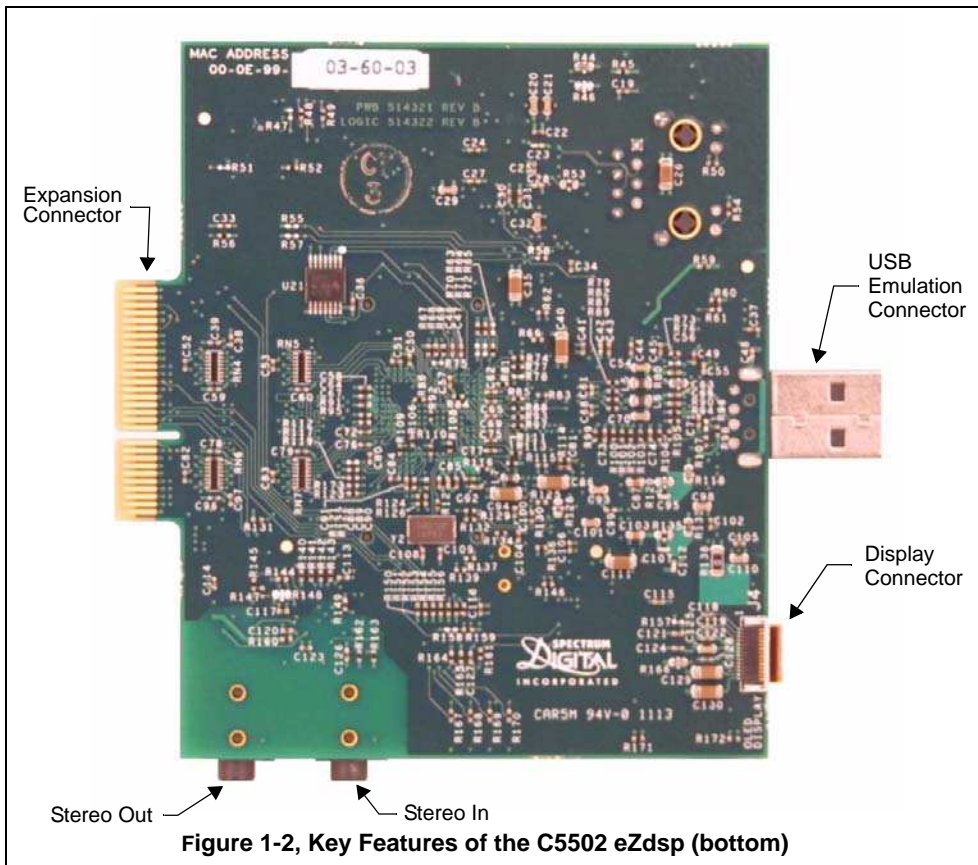

Figure 1-2, Key Features of the C5502 eZdsp (bottom)

1.1 Key Features of the C5502 eZdsp

The C5502 eZdsp has the following features:

- Texas Instrument's TMS320C5502 Digital Signal Processor
- Texas Instruments TLV320AIC3204 Stereo Codec (stereo in, stereo out)
- 10/100 Ethernet controller with RJ45 interface
- Fingerprint sensor interface
- 64 Megabit SPI Flash (boot default)
- 8 Megabytes of SDRAM (32 bits wide)
- 1.3" OLED display
- 5 user controlled LEDs
- 2 user readable push button switches
- Embedded USB XDS100v2 JTAG emulator with UART interface option
- TI Wireless interface connectors
- Expansion edge connector
- Power provided by USB interface
- Compatible with Texas Instruments Code Composer Studio v4
- USB extension cable

1.2 C5502 eZdsp Block Diagram

The block diagram of the C5502 eZdsp is shown below.

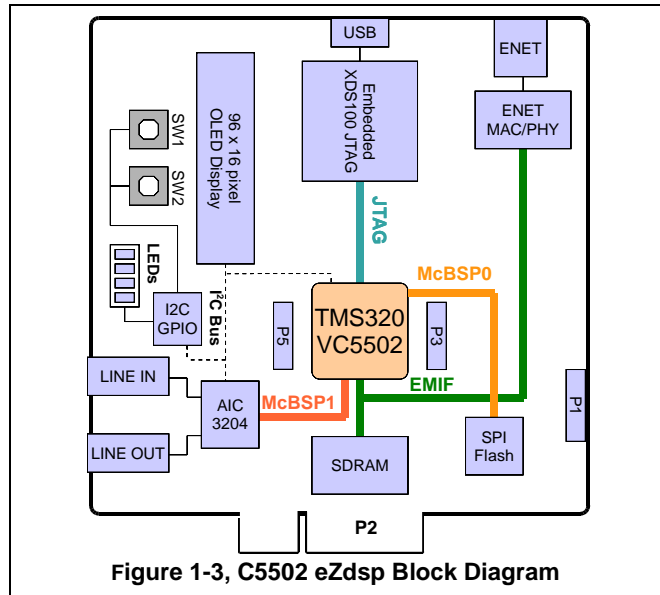

1.3 C5502 eZdsp Memory Map

The C5502 eZdsp supports on chip DARAM, off chip SDRAM, and a memory mapped Ethernet controller. The addressing for each of these memory blocks is shown in the figure below.

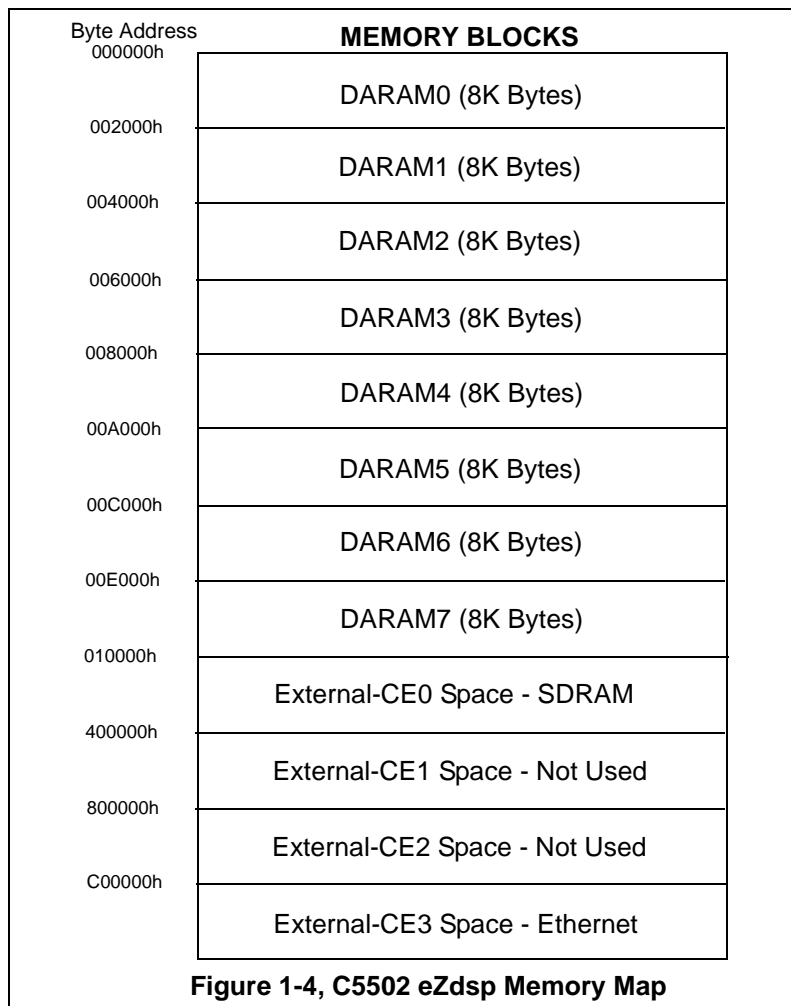

1.4 C5502 eZdsp I²C Addressing

The C5502 eZdsp has multiple I²C devices for different purposes. The table below shows the addresses of these devices on the I²C bus.

Table 1: C5502 eZdsp I²C Addresses

eZdsp I ² C Device	I ² C Address	Function
TLV320AIC3204	0x18	Audio CODEC
TCA6416PW	0x21	I ² C Expander bit I/O
OSD9616GLBGG01	0x3C	OLED Display

1.4.1 I²C Expander Definition

The C5502 eZdsp board incorporates a 16 bit I²C Expander to implement user bit I/O and the selecting/enabling of on-board multiplexing options.

The expander is configured as two 8-bit ports, Port0 and Port1. The bit functions for Port0 are shown in the table below.

Table 2: Port0 I²C Expander Definition

Port0 Bit Number	I/O Direction	Function
P00	I/O	Expansion connector
P01	I/O	Expansion connector
P02	I	SW2 Push Button
P03	I	SW1 Push Button
P04	O	DS3, "0" turns on LED
P05	O	DS4, "0" turns on LED
P06	O	DS5, "0" turns on LED
P07	O	DS6, "0" turns on LED

The bit functions for Port1 are shown in the table below

Table 3: Port1 I²C Expander Definition

Port1 Bit Number	I/O Direction	Function
P10	I/O	Expansion connector
P11	I/O	Expansion connector
P12	I/O	Expansion connector
P13	O	Enable FTDI UART on XDS100v2 0 = enables 5502 UART to FTDI chip 1 = disables 5502 UART to FTDI chip
P14	O	BSP_Sel1_enable 0 = enables McBSP1 Mux 1 = disables McBSP1 Mux
P15	O	BSP_Sel1 0 = Selects McBSP1 to on board AIC when enabled 1 = Selects McBSP1 to finger print connector
P16	O	BSP_Sel0_enable 0 = enables McBSP0 Mux 1 = disables McBSP0 Mux
P17	O	BSP_Sel0 0 = Selects McBSP0 to TI wireless connectors I ² S channel ON when enable is low 1 = Selects McBSP0 to SPI channel on TI wireless connectors when enable is low

Physical Description

This chapter describes the physical layout of the TMS320C5502 eZdsp.

Topic	Page
2.0 Board Layout	2-2
2.1 Connector Index	2-4
2.1.1 J1, XDS100 USB Connector	2-5
2.1.2 J2, Stereo In Connector	2-5
2.1.3 J3, Headphones Out Connector	2-6
2.1.4 J4, LCD Interface	2-7
2.1.5 P1, Fingerprint Sensor Interface	2-8
2.1.6 P2, Ethernet Interface	2-9
2.1.7 P3, P5, TI Wireless Interface	2-10
2.1.8 P4, Expansion Connector	2-11
2.2 System LEDs	2-13
2.3 Switches	2-13
2.4 Test Points	2-14

2.0 Board Layout

The C5502 eZdsp is a 3.4 x 3.7 inch six (6) layer printed circuit board which is powered off the USB bus of personal computer or laptop computer. This means this board does not require an external power supply.

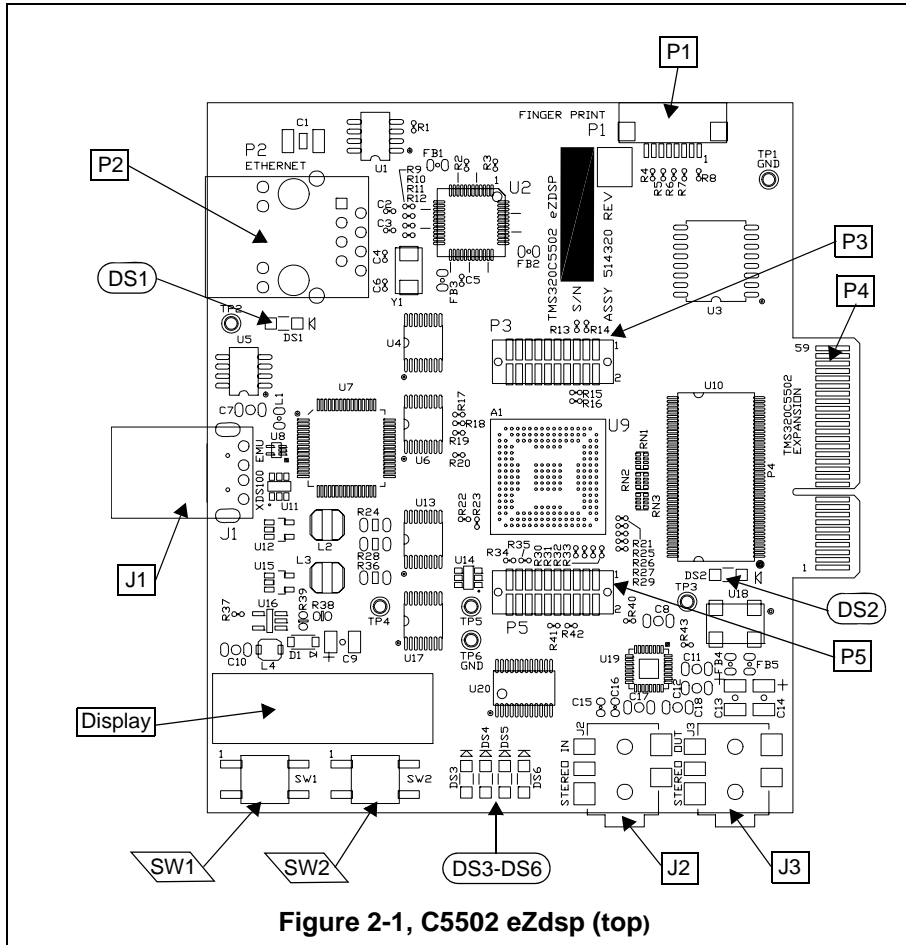

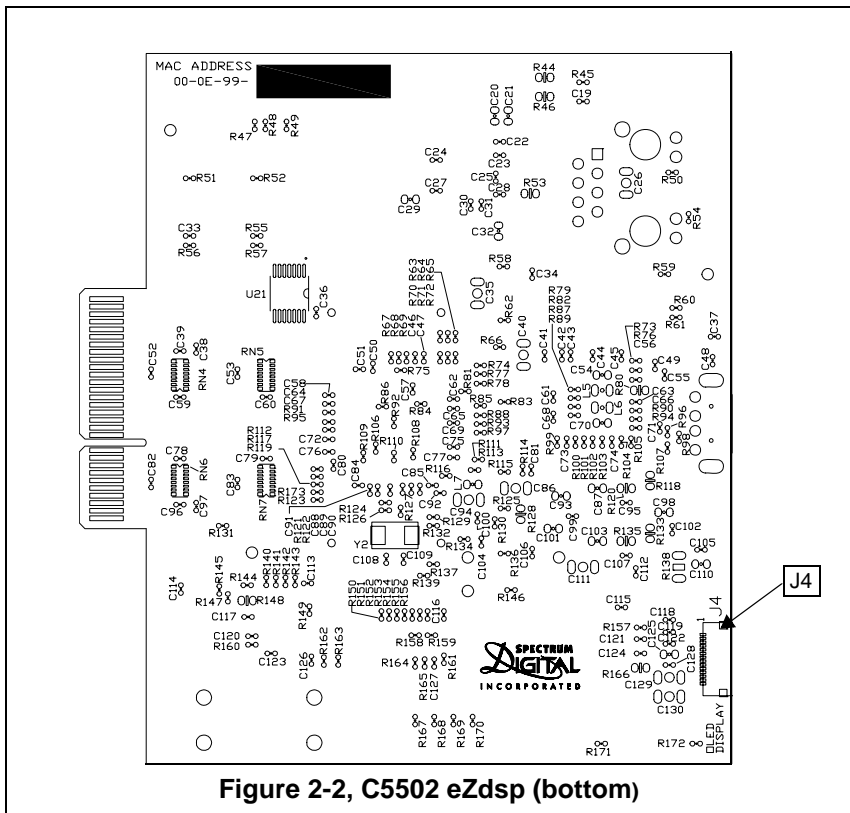

Figure 2-2, C5502 eZdsp (bottom)

2.1 Connector Index

The C5502 eZdsp has nine (9) connectors which provide the user access to various signals on the C5502 eZdsp. These connectors are shown in the table below.

Table 1: C5502 eZdsp Connectors

Connector	# Pins	Function	Schematic Page	Board Side
J1	6	Emulation USB	17	Top
J2	2	Stereo In	11	Top
J3	2	Headphones Out	11	Top
J4	14	LCD Interface	13	Bottom
P1	8	Fingerprint Sensor Interface	15	Top
P2	16	Ethernet Interface	12	Top
P3	20	TI Wireless Interface	9	Top
P4	30 x 2	Expansion	16	Top/Bottom
P5	20	TI Wireless Interface	9	Top

The following manufacturer and parts numbers can be used to interface to the connectors on the C5502 eZdsp:

Table 2: C5502 eZdsp Mating Connectors

Connector	Manufacturer	Part #
J1	PC or laptop	
J3	CUI Inc	CUI SP-3501, Digi-Key CP-3502-ND
J4	CUI Inc	CUI SP-3501, Digi-Key CP-3502-ND
P4	Samtec	Samtec MEC1-130-02-S-D-A, Digi-Key SAM8118-ND Samtec MEC1-130-02-S-D-RAI-SL

2.1.1 J1, XDS100 USB Connector

The USB connector, J1, is used to attach the C5502 eZdsp to a personal computer or laptop. This allows the user to develop and debug software on the C5502 eZdsp. The signals on the pins of this connector are shown below.

Table 3: J1, XDS100 USB Connector

Pin #	Signal Name
1	5V_USB
2	D+
3	D-
4	GND
5	Shield Ground
6	Shield Ground

2.1.2 J2, Stereo In Connector

The Stereo In connector, J2, is used to bring signals into the TLV320AIC3204 codec. The signals on the pins of this connector are shown below.

Table 4: J2, Stereo In Connector

Pin #	Signal Name	AIC3204 Pin #
1	GND-AIC	
2	AIC_LINE2L	15
3	AIC_LINE2R	16
4	No connect	
5	No connect	

The figure below shows a typical stereo jack.

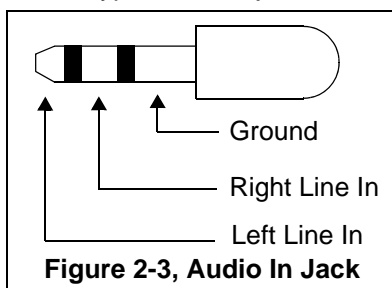

2.1.3 J3, Headphones Out Connector

The Headphones Out connector, J3, is used to bring signals from the TLV320AIC3204 codec. The signals on the pins of this connector are shown below.

Table 5: J3, Headphones Out Connector

Pin #	Signal Name	AIC3204 Pin #
1	GND-AIC	
2	HEADPHONE_LOUT	25
3	HEADPHONE_ROUT	27
4	No connect	
5	No connect	

The figure below shows a typical headphone jack.

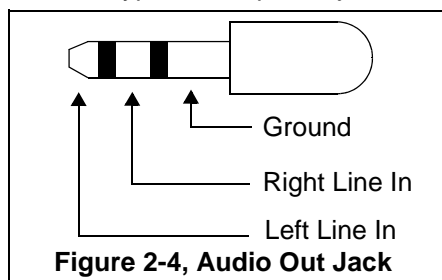

2.1.4 J4, LCD Interface

Connector, J4, is used to interface to an LCD character display. The signals on the pins of this connector are shown below.

Table 6: J4, LCD Interface

Pin #	Signal Name
1	C2P
2	C2N
3	C1P
4	C1N
5	VBAT
6	VBREF
7	VSS / GND
8	VDD / VCC_3V3
9	RESn / TARGET_PWR_GOOD
10	SCL / I2C_SCL
11	SDA / I2C_SDA
12	IREF / GND
13	VCOMH
14	VCC / V13

2.1.5 P1, Fingerprint Sensor Interface

Connector P1 is a 1 x 8 pin connector that allows a fingerprint sensor to be plugged into the C5502 eZdsp. The signals on this connector are shown in the table below.

Table 7: P1, Fingerprint Sensor Interface

Pin #	Signal Name
1	SPI_RX
2	VCC_3V3
3	SPI_RESET
4	SPI_CLK
5	GND
6	SPI_DX
7	SPI_CS
8	GND

2.1.6 P2, Ethernet Interface

Connector P2 is a standard RJ45 Ethernet connector allowing the C5502 eZdsp to communicate over Ethernet. The signals present on this connector are shown in the table below.

Table 8: P2, Ethernet Interface

Pin #	Signal Name
1	TXD+ / TXP1, U2, Pin 19
2	TXD- / TXM1, U2, Pin 20
3	RXD+ / RXP1, U2, Pin 16
4	TXD-CT / ENET_3V3A
5	RXD-CT / ENET_3V3A
6	RXD- / RXM1, U2, Pin 17
7	NC1
8	GND
9	LED1+ / VCC_3V3
10	LED1- / P1LED0
11	LED2+ / VCC_3V3
12	LED2- / P1LED1
MH1	NC
MH2	NC
SH1	GND_E_ENET
SH2	GND_E_ENET

The unique Ethernet MAC address for each C5502 eZdsp is programmed into non-volatile memory on the board. It is also shown on the bottom side of the board. The figure shows the position of the MAC address (different for each eZdsp).



Figure 2-5, Ethernet MAC Address Location

2.1.7 P3, P5, TI Wireless Interface

Connectors P3, and P5 are expansion connectors used to provide an interface to TI Wireless modules board. The signals on the pins of these connectors are shown in the tables below.

Table 9: P3, TI Wireless Interface

Pin #	Signal Name	Pin #	Signal Name
1	GND	2	NC
3	UART_RTS/GPIO3	4	NC
5	TIMER/TIM0	6	NC
7	UARTTX	8	NC
9	UARTRX	10	GPIO6
11	I2C_SDA	12	GPIO7
13	I2C_SCL	14	CC_SPI_CS
15	NC	16	CC_SPI_CLK
17	NC	18	CC_SPI_MOSI
19	GND	20	CC_SPI_MOSO

Table 10: P5, TI Wireless Interface

Pin #	Signal Name	Pin #	Signal Name
1	NC	2	GND
3	NC	4	NC
5	NC	6	NC
7	VCC_3V3	8	CC_I2S_RX
9	VCC_3V3	10	CC_I2S_TX
11	CC_I2S_FS	12	NC
13	GPIO25	14	NC
15	GPIO26	16	NC
17	CC_I2S_CLK	18	GPIO5
19	GPIO26	20	GPIO35

2.1.8 P4, Expansion Connector

The Expansion connector, P4, is used to bring signals from C5502 DSP out to a connector for user interface. This card edge connector has all of the odd number (1,3,...,59) tabs on the top side of the board and all of the even number tabs (2,4,...,46) on the bottom side of the board. The diagram below shows the position of these tabs.

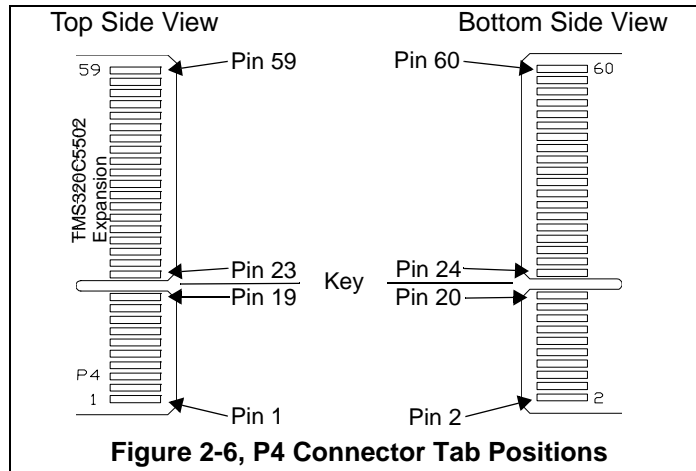

The table below lists the signals that appear on each of the tabs of connector P4. The signals on the pins of this connector are shown below.

Table 11: P4, Expansion Connector

Pin # Top	Signal Name	Pin # Bottom	Signal Name
1	GND	2	GND
3	SPI_CS	4	GPIO1
5	SPI_CLK	6	GPIO0
7	SPI_DX	8	GPIO35
9	SPI_RX	10	TIM0
11	GND	12	GND
13	GND	14	GND
15	GND	16	GND
17	I2C_SDA	18	GPIO7
19	I2C_SDL	20	GPIO2
	Key		Key
23	CC_I2S_CLK	24	I2C_P01
25	CC_I2S_RX	26	I2C_P00
27	CC_I2S_TX	28	DX2
29	CC_I2S_FS	30	DR2
31	GND	32	GND
33	GPIO6	34	GPIO3
35	GPIO33	36	GPIO5
37	GPIO25	38	UARTRX
39	GPIO26	40	UARTTX
41	VCC_3V3	42	VCC_3V3
43	VCC_3V3	44	VCC_3V3
45	AIC_BCLK	46	TIM1
47	AIC_DOUT	48	VCC_3V3
49	AIC_DIN	50	PGPIO39
51	AIC_WCLK	52	PGPIO38
53	I2C_P10	54	PGPIO37
55	I2C_P11	56	PGPIO36
57	VCC_3V3	58	VCC_3V3
59	VCC_3V3	60	VCC_3V3

2.2 System LEDs

The C5502 eZdsp has 6 Light Emitting Diodes (LED). Five of the six LEDs are under the application software control running on the C5502 processor. These LEDs are shown in the table below.

Table 12: System LEDs

LED #	Color	Schematic Page	Signal Name
DS1	Green	17	Emulator status
DS2	Green	2	U9, Pin T6,C5502 XF
DS3	Green	14	U20, Pin 8, LED3
DS4	Red	14	U20, Pin 9, LED2
DS5	Yellow	14	U20, Pin 10, LED1
DS6	Blue	14	U20, Pin 11, LED0

2.3 Switches

The C5502 eZdsp has two push button switches. The push button switches (SW1, SW2) can be read by application software running on the C5502 processor. These switches are shown in the table below.

Table 13: Switches

Switch #	Type	Schematic Page	Signal Name/Reading
SW1	Push button	14	SW0, U20, Pin 7
SW2	Push button	14	SW1, U20, Pin 6

2.4 Test Points

The C5502 eZdsp has six (6) test points for the monitoring of signals. The location of the test points are shown in the figure below.

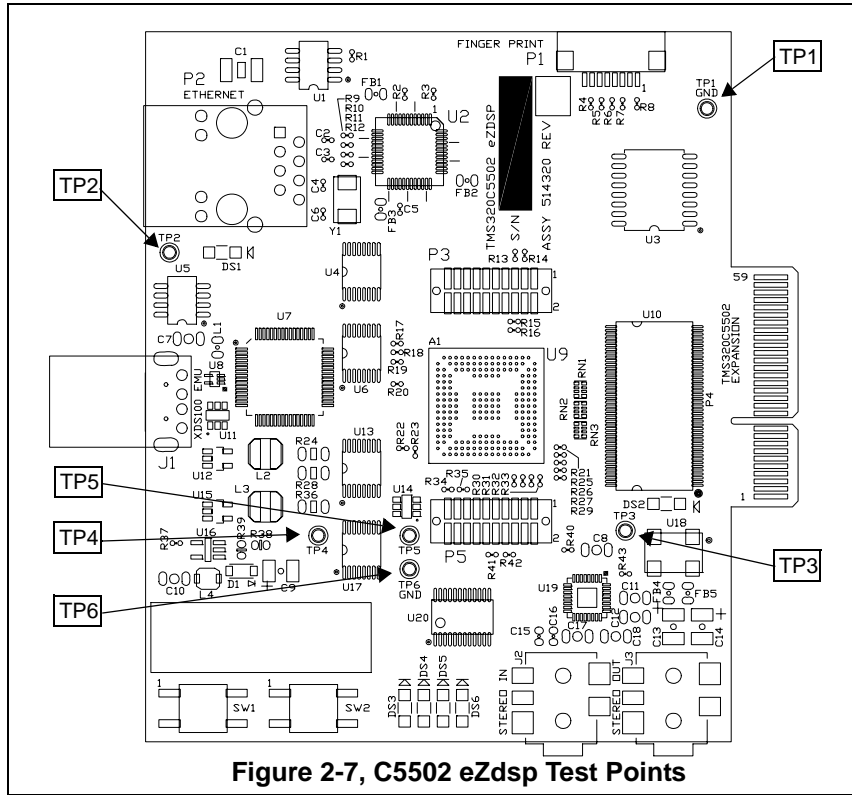

The signals on the test points are shown in the table below.

Table 14: Test Points

TP #	Schematic Page	Signal Name
TP1	6	GND
TP2	10	TARGET_PWR_GOOD, VCC_3V3
TP3	10	VCC_3V3
TP4	10	VCC_1V26
TP5	5	CLKOUT, U9, Pin R6
TP6	11	GND

Appendix A

Schematics

This appendix contains the schematics for the TMS320C5502 eZdsp.

NOTES, UNLESS OTHERWISE SPECIFIED:

1. RESISTANCE VALUES IN OHMS.
2. CAPACITANCE VALUES IN MICROFARADS.
3. REFERENCE DESIGNATORS USED:
4. ALL 0.1 uF AND 0.01uF CAPACITORS ARE DECOUPLING CAPS UNLESS OTHERWISE NOTED. THEY ARE SHOWN ON THE PAGE WITH THE INTEGRATED CIRCUITS THEY SHOULD BE PLACED NEAR.

REV	DESCRIPTION	DATE	APPROVED
A	Initial schematic for layout	11/15/2010	RRP
B	Added SDRAM/SPI FLASH/General updates	2/15/2011	RRP

SCHMATIC CONTENTS

- 01 - TITLE PAGE
- 02 - TMS320C5502 GPIO/BSP/SPI/I2C
- 03 - McBSP MUXES
- 04 - TMS320C5502 CLK/JTAG
- 05 - TMS320C5502 EMIF
- 06 - TMS320C5502 POWER
- 07 - SPI FLASH
- 08 - SDRAM
- 09 - CC BOARD INTERFACE
- 10 - POWER SUPPLIES
- 11 - AUDIO CODEC
- 12 - ETHERNET CONTROLLER
- 13 - LCD INTERFACE
- 14 - USER LEDS/SWITCHES
- 15 - FINGERPRINT INTERFACE
- 16 - EXPANSION CONNECTOR
- 17 - XDS100-v2 INTERFACE

REVISION STATUS OF SHEETS

REV	1	2	3	4	5	6	7	8	9	10	DESCRIPTION	DATE	BY			
SHEET																
REV											ENR	R.R.P.	11/15/2010			
SHEET													ENK			
REV														T.W.K.	11/15/2010	
SHEET														ENGR	R.R.P.	11/15/2010
REV	A	A	A	A	A	A	A							ENGR-MJR	R.R.P.	11/15/2010
SHEET	11	12	13	14	15	16	17							DA	C.M.D.	11/15/2010
REV	B	A	B	A	A	A	A	B	A	A	NEXT ASSY	USED ON		RFU	R.R.P.	11/15/2010
SHEET	1	2	3	4	5	6	7	8	9	10	APPLICATION			ELSE	R.R.P.	11/15/2010

SPECTRUM DIGITAL INCORPORATED		
Title: TMS320C5502 EZDSP MODULE		
Page Contents: TITLE SHEET		
Size: B	DWG NO 514322-0001	Revision: B
Date: Wednesday, August 17, 2011	Sheet 1 of 17	

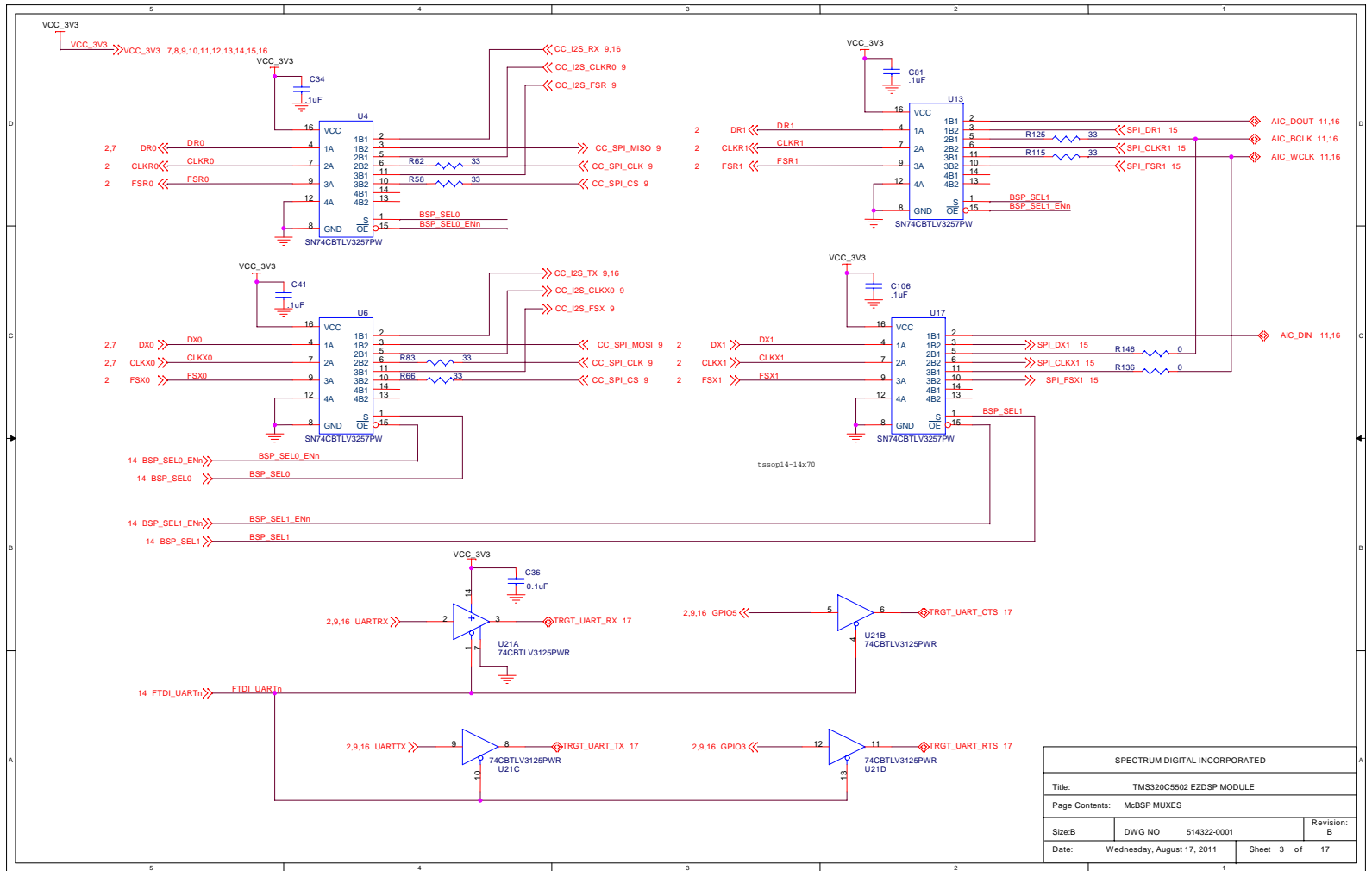

SPECTRUM DIGITAL INCORPORATED			
Title: TMS320C5502 EZDSP MODULE			
Page Contents: McBSP MUXES			
Size:B	DWG NO	514322-0001	Revision: B
Date:	Wednesday, August 17, 2011	Sheet 3 of 17	

CORE CLOCK IS INPUT CLOCK DIVIDED BY
 DIVIDER D0 TIMES PLL
 DIVIDER D0 = DIVIDE BY 1 TO 32
 MULTIPLIER = TIMES 2 TO 15

CPU_3V3
 CPU_3V3 >> CPU_3V3 2.5,6,10

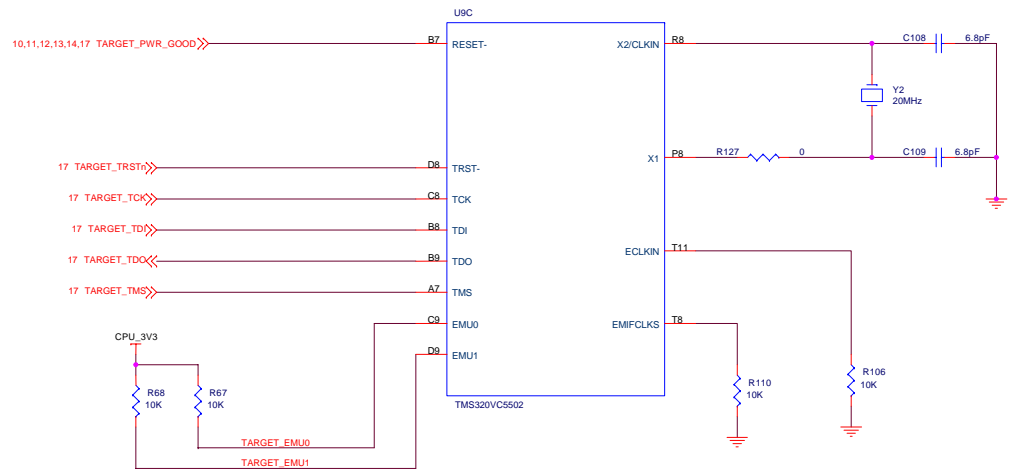

SPECTRUM DIGITAL INCORPORATED		
Title: TMS320C5502 EZDSP MODULE		
Page Contents: CLOCK,JTAG,USB		
Size:B	DWG NO 514322-0001	Revision: A
Date: Wednesday, August 17, 2011	Sheet 4 of 17	

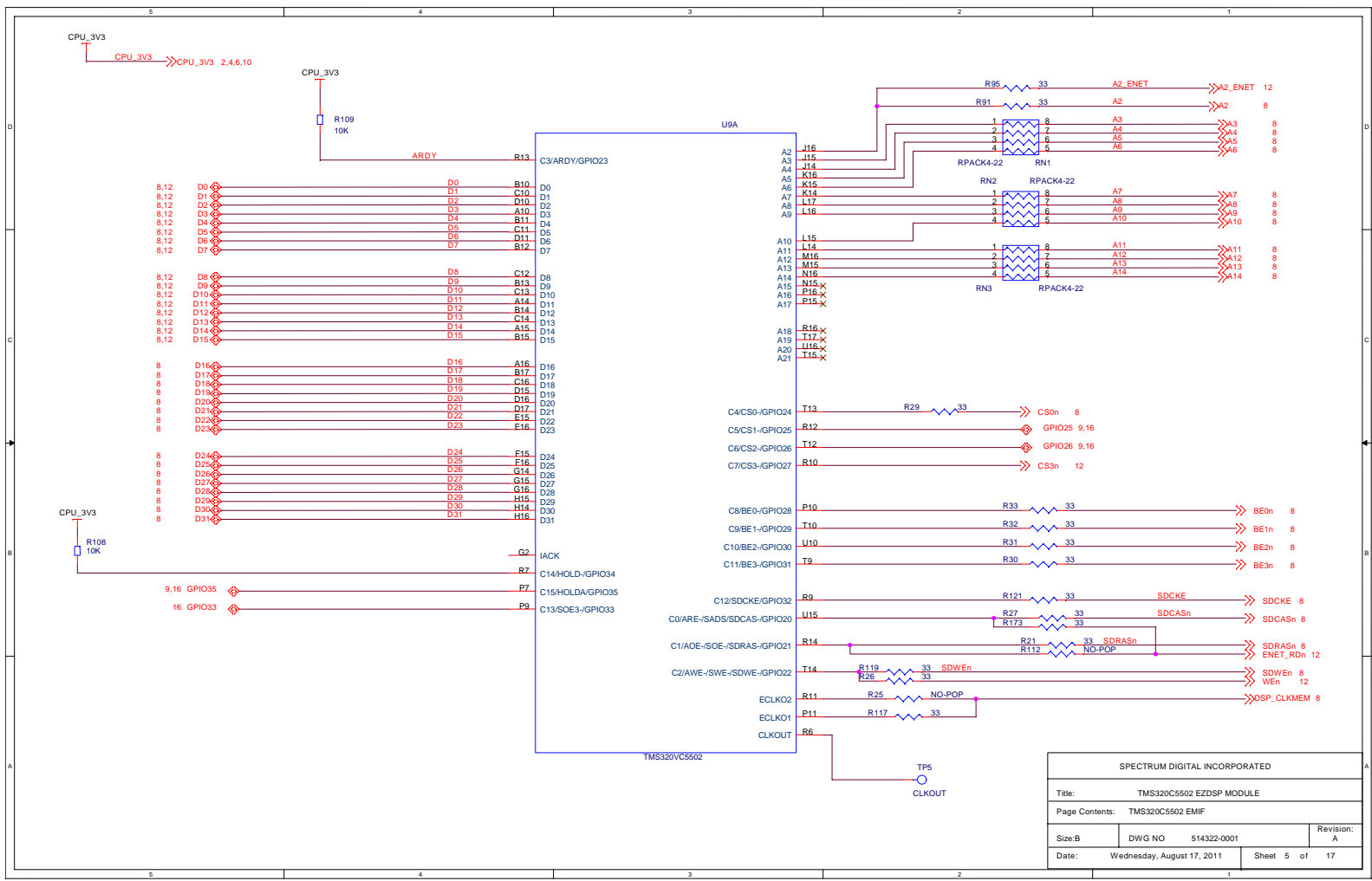

SPECTRUM DIGITAL INCORPORATED			
Title: TMS320C5502 EZDSP MODULE			
Page Contents: TMS320C5502 EMIF			
Size: B	DWG NO	514322-0001	Revision: A
Date: Wednesday, August 17, 2011	Sheet 5 of 17		

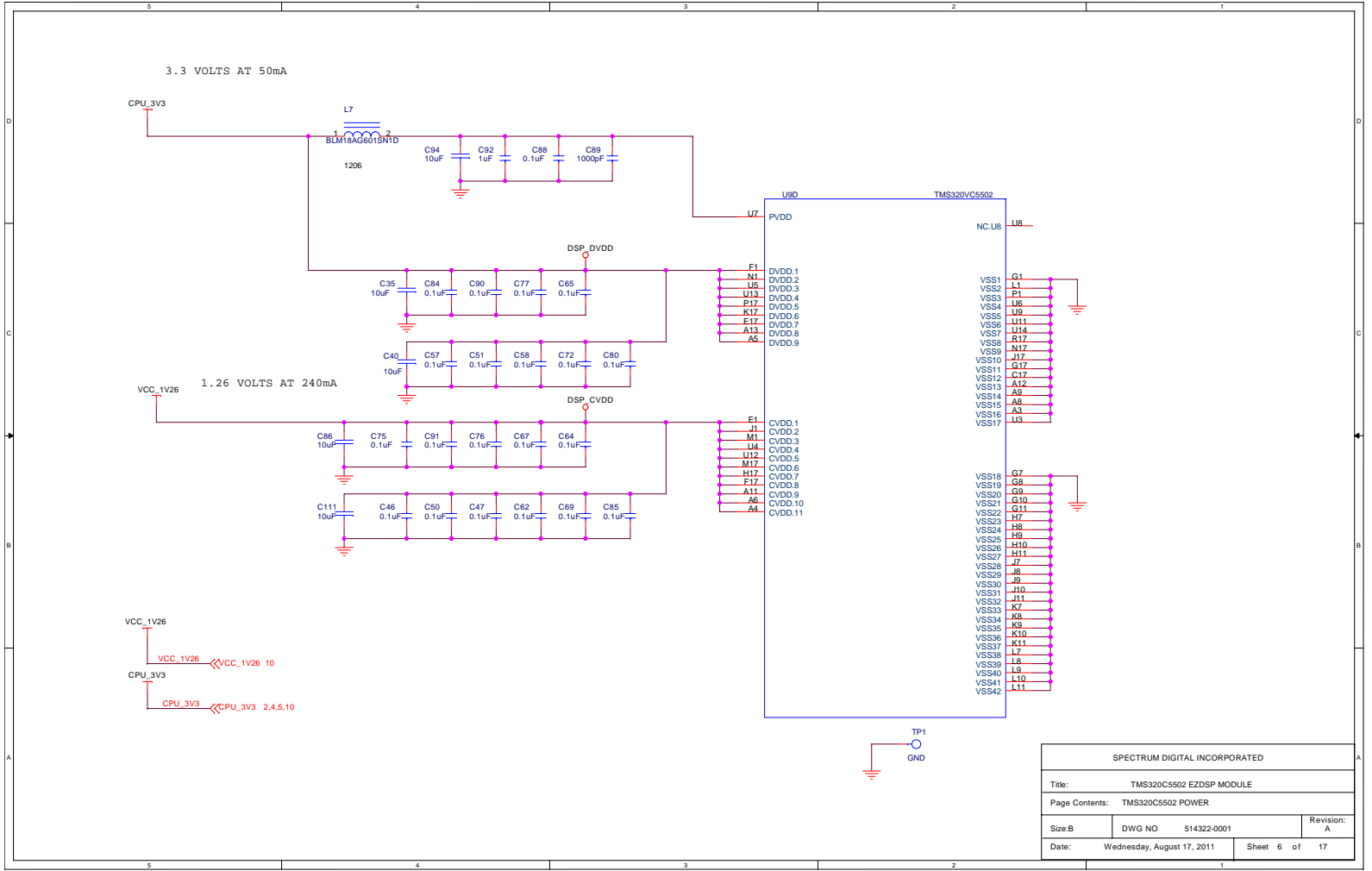

SPECTRUM DIGITAL INCORPORATED			
Title: TMS320C5502 EZDSP MODULE			
Page Contents: TMS320C5502 POWER			
Size B	DWG NO	514322-0001	Revision: A
Date:	Wednesday, August 17, 2011	Sheet 6	of 17

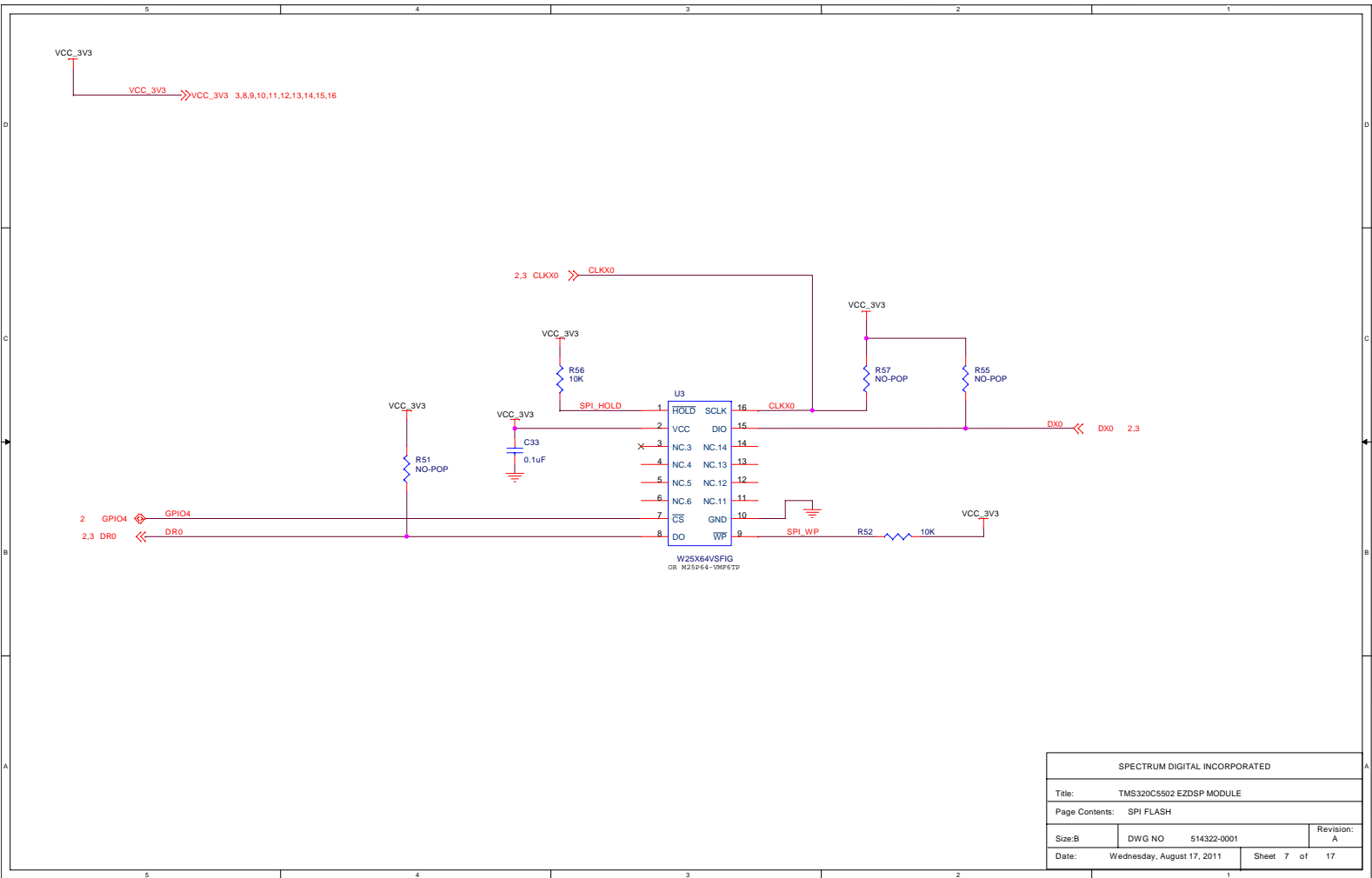

SPECTRUM DIGITAL INCORPORATED		
Title: TMS320C5502 EZDSP MODULE		
Page Contents: SPI FLASH		
Size: B	DWG NO: 514322-0001	Revision: A
Date: Wednesday, August 17, 2011	Sheet 7 of 17	

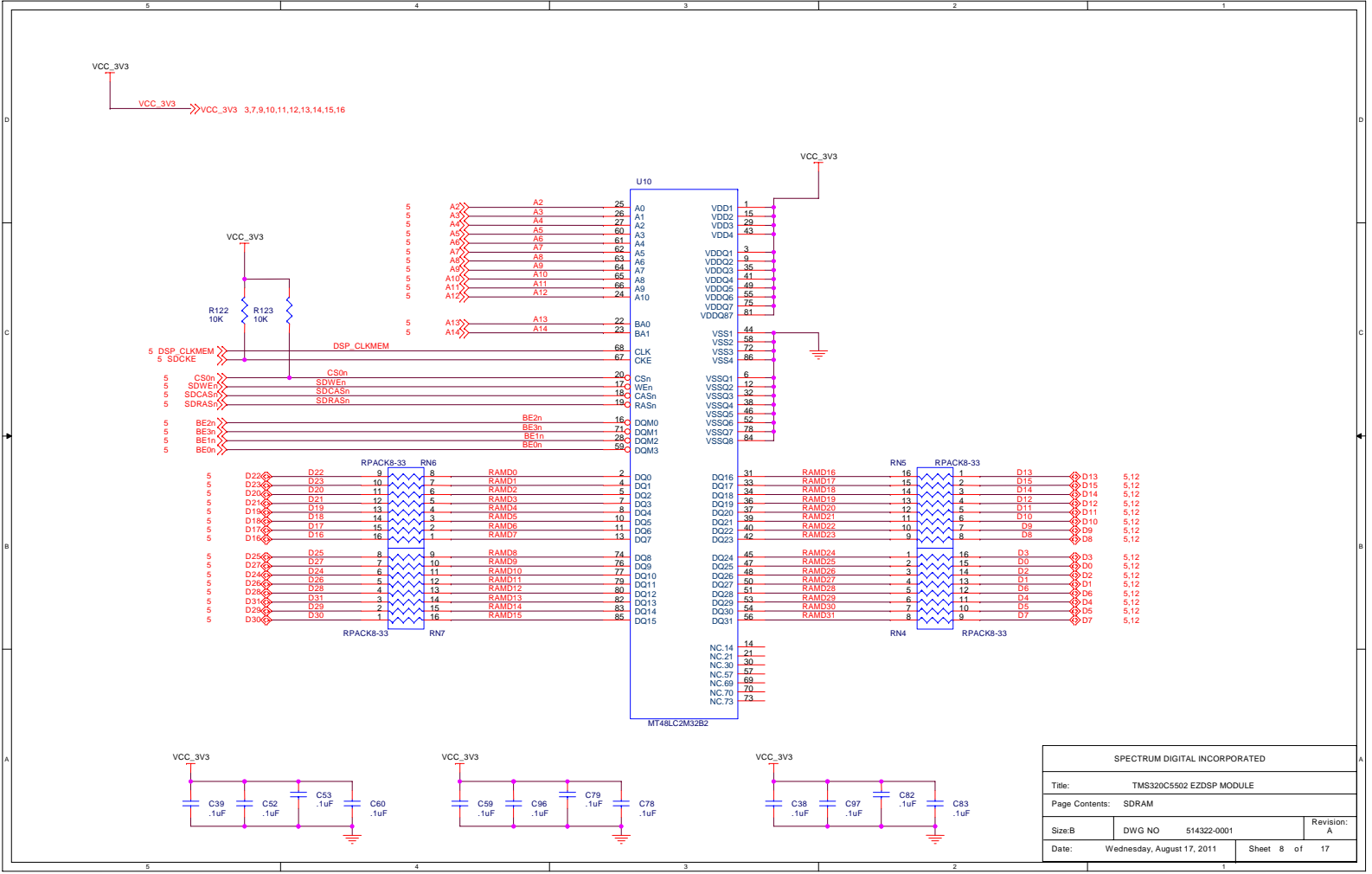

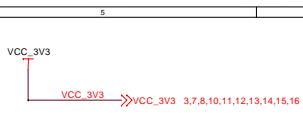

NOTE: DIMENSIONS AND LOCATIONS OF THESE CONNECTORS MUST MEET SPECIFICATION FOR INTERFACE MODULES

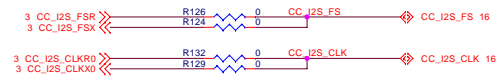
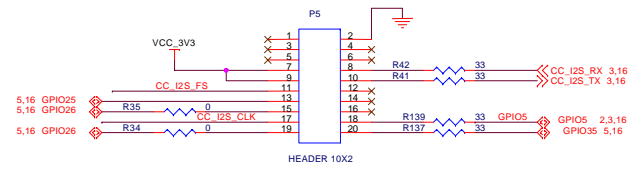
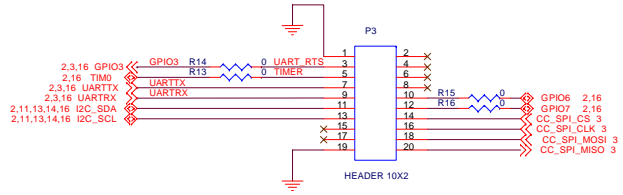

SPECTRUM DIGITAL INCORPORATED			
Title: TMS320C5502 EZDSP MODULE			
Page Contents: CC BOARD INTERFACE			
Size: B	DWG NO	514322-0001	Revision: B
Date:	Wednesday, August 17, 2011	Sheet 9 of	17

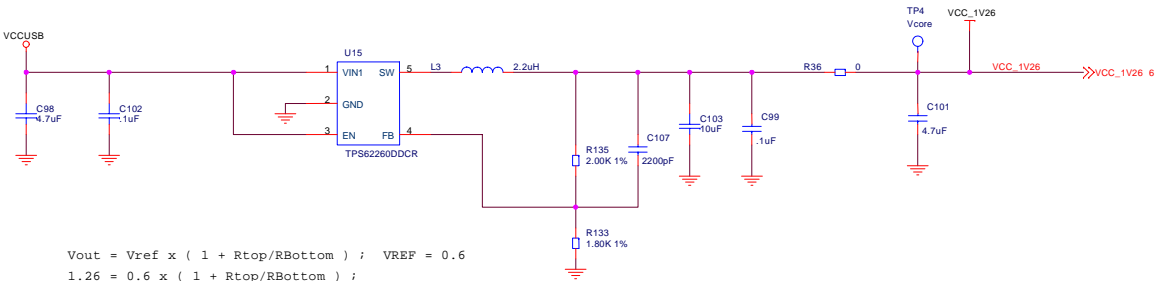

$V_{out} = V_{ref} \times (1 + R_{top}/R_{bottom}) ; V_{REF} = 0.6$
 $1.26 = 0.6 \times (1 + R_{top}/R_{bottom}) ;$
 $2.1 = (1 + R_{top}/R_{bottom}) ;$
 $1.1 R_{bottom} = R_{top} ;$

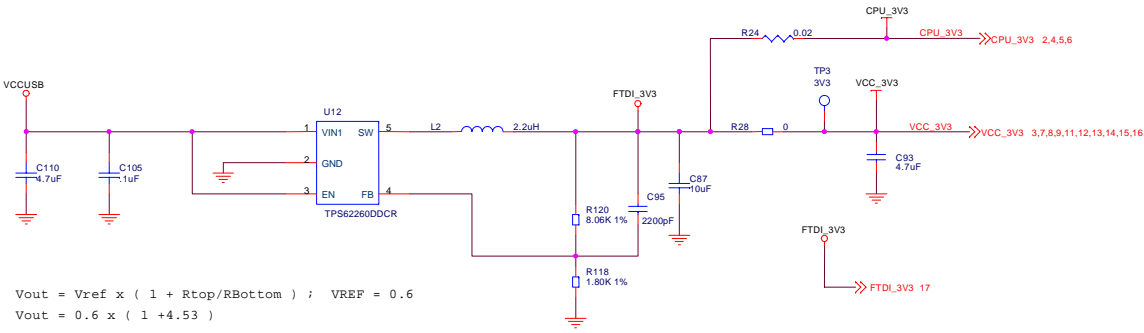

$V_{out} = V_{ref} \times (1 + R_{top}/R_{bottom}) ; V_{REF} = 0.6$
 $V_{out} = 0.6 \times (1 + 4.53)$

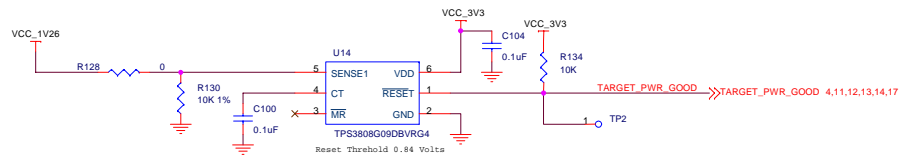

SPECTRUM DIGITAL INCORPORATED			
Title: TMS320C5502 EZDSP MODULE			
Page Contents: POWER MANAGEMENT			
Size: B	DWG NO	514322-0001	Revision: A
Date: Thursday, September 01, 2011	Sheet 10 of 17		

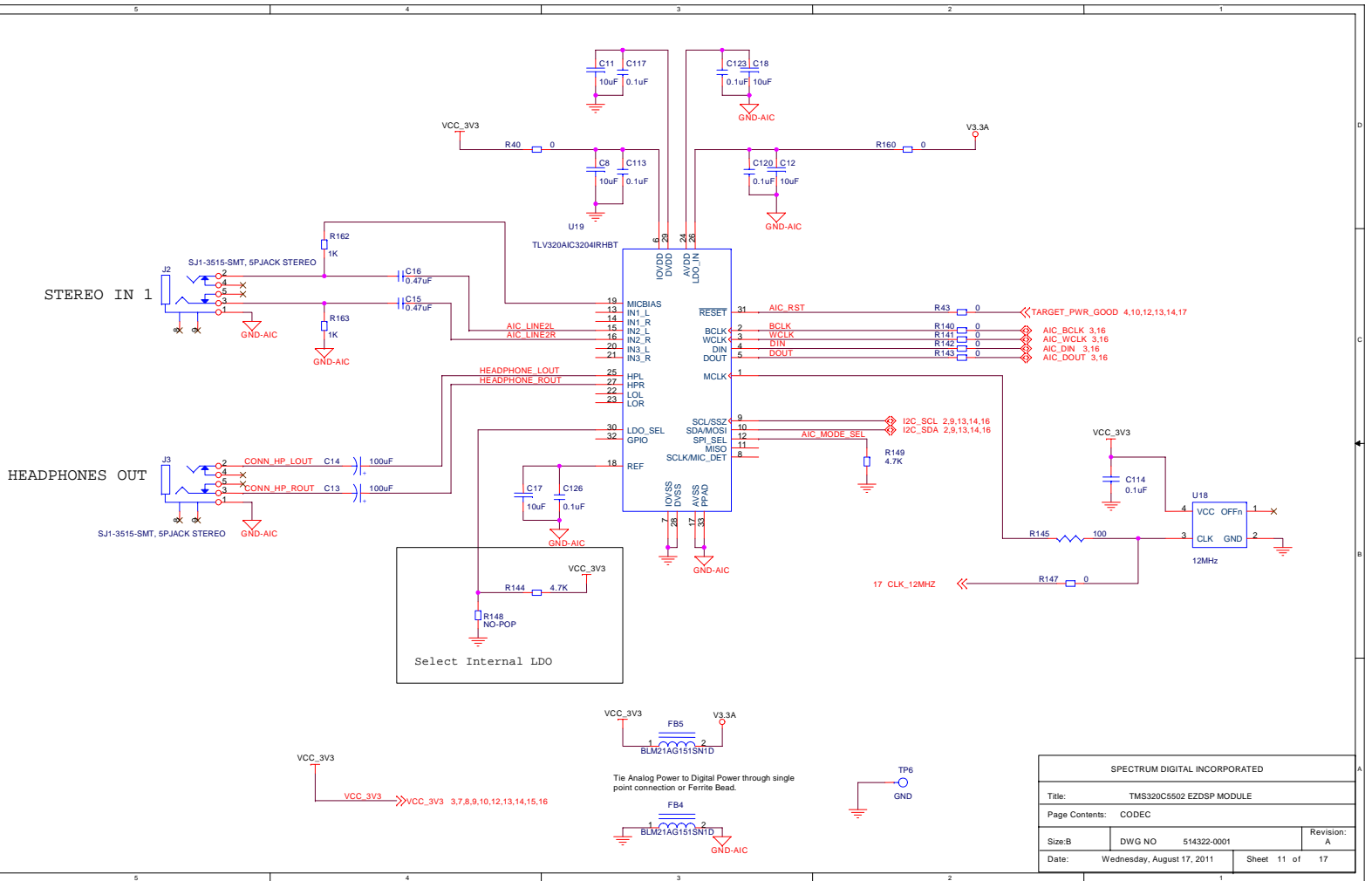

SPECTRUM DIGITAL INCORPORATED			
Title: TMS320C5502 EZDSP MODULE			
Page Contents: CODEC			
Size:B	DWG NO	514322-0001	Revision: A
Date:	Wednesday, August 17, 2011	Sheet	11 of 17

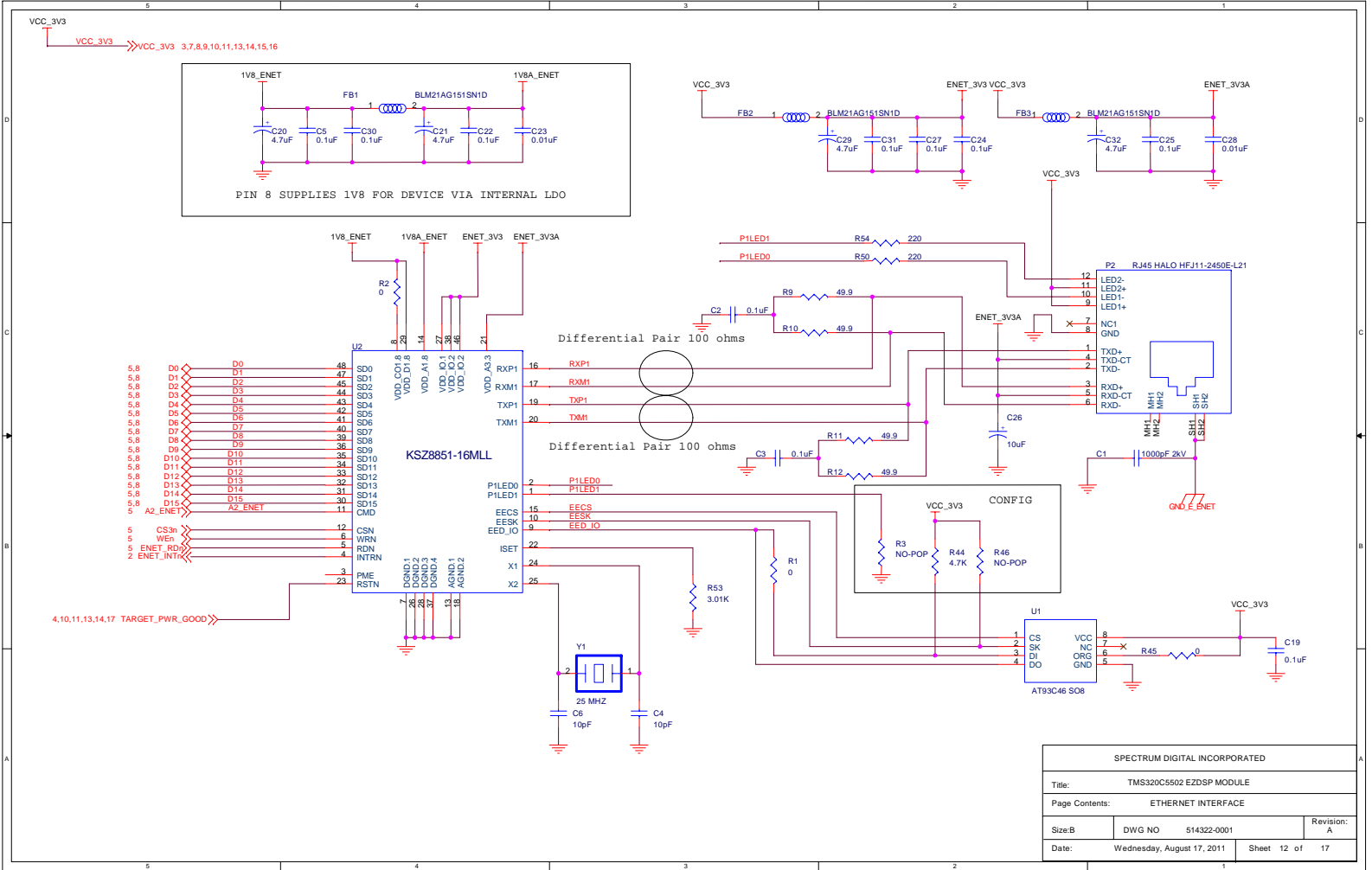

SPECTRUM DIGITAL INCORPORATED			
Title: TMS320C5502 EZDSP MODULE			
Page Contents: ETHERNET INTERFACE			
Size: B	DWG NO	514322-0001	Revision: A
Date:	Wednesday, August 17, 2011	Sheet	12 of 17

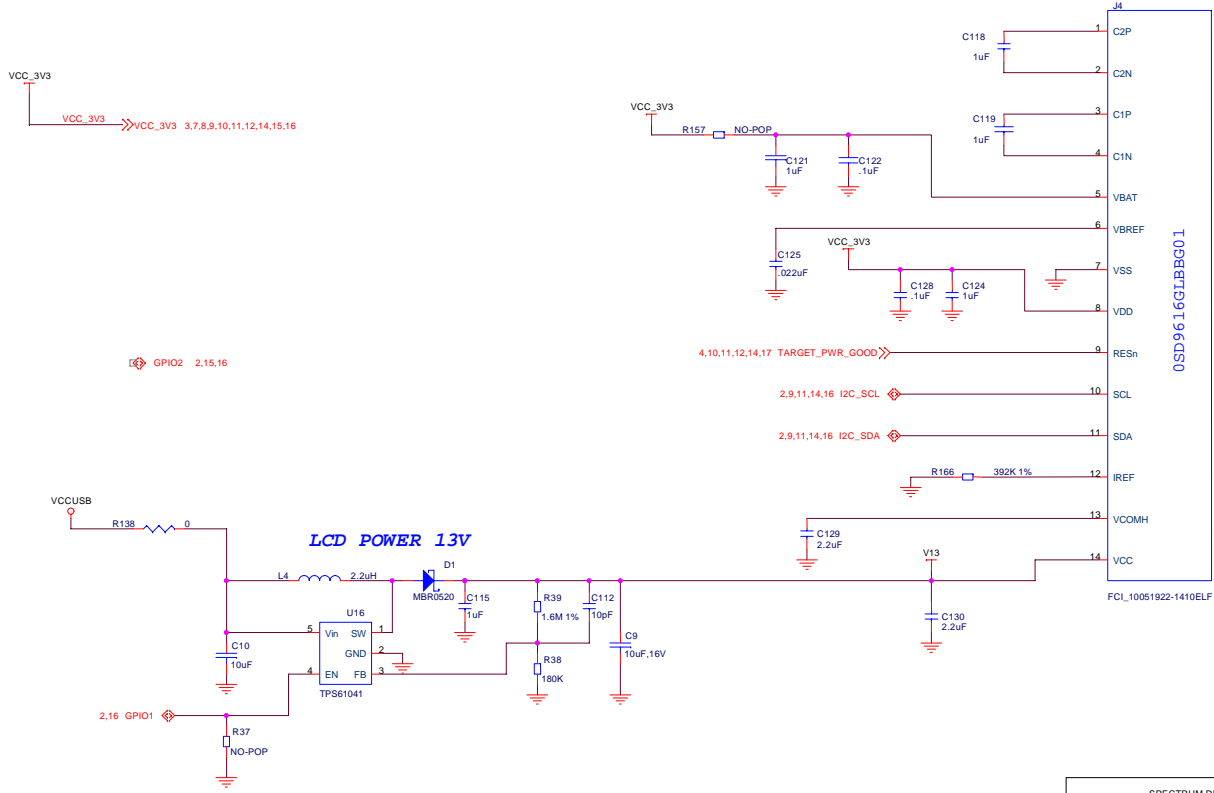

SPECTRUM DIGITAL INCORPORATED			
Title: TMS320C5502 EZDSP MODULE			
Page Contents: LCD INTERFACE			
Size: B	DWG NO: 514322-0001	Revision: A	
Date: Wednesday, August 17, 2011	Sheet 13 of 17		

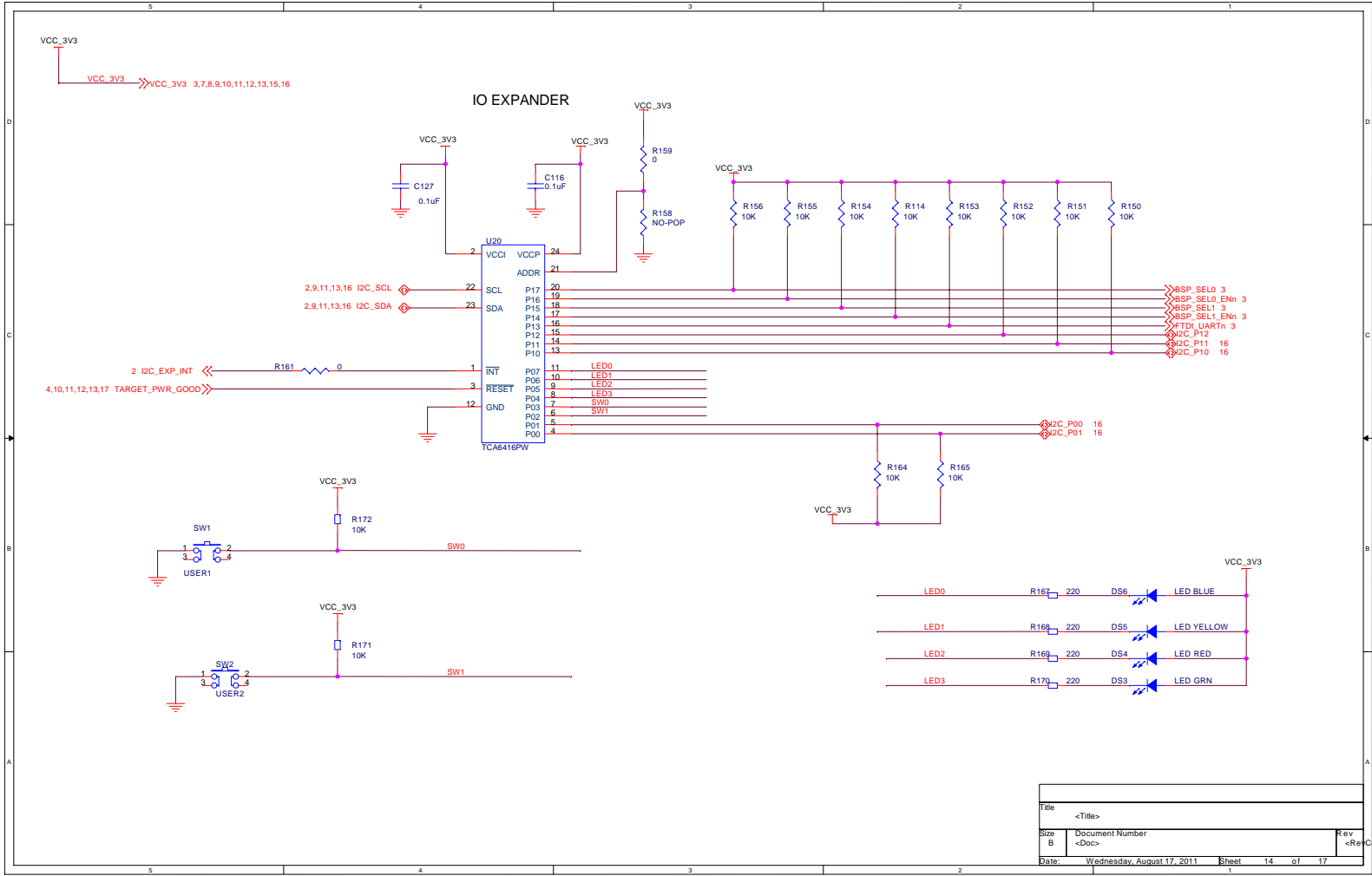

Title	<Title>	Rev	<Rev>
Size	Document Number		
B	<Doc>		
Date:	Wednesday, August 17, 2011	Sheet	14 of 17

VCC_3V3
 VCC_3V3 >>> VCC_3V3 3,7,8,9,10,11,12,13,14,16

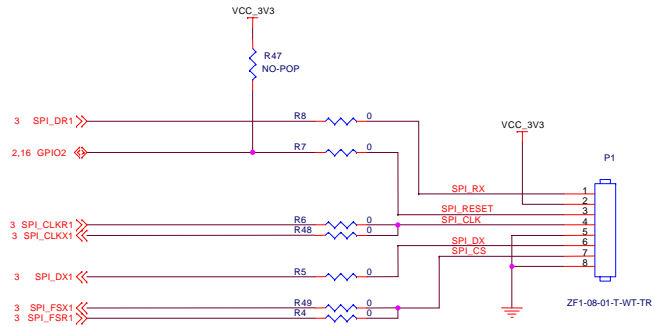

SPI_RX <-> SPI_RX 16
 SPI_CLK <-> SPI_CLK 16
 SPI_DX <-> SPI_DX 16
 SPI_CS <-> SPI_CS 16

SPECTRUM DIGITAL INCORPORATED			
Title: TMS320C5502 EZDSP MODULE			
Page Contents: FINGER PRINT CONNECTOR			
Size: B	DWG NO	514322-0001	Revision: A
Date:	Wednesday, August 17, 2011		Sheet 15 of 17

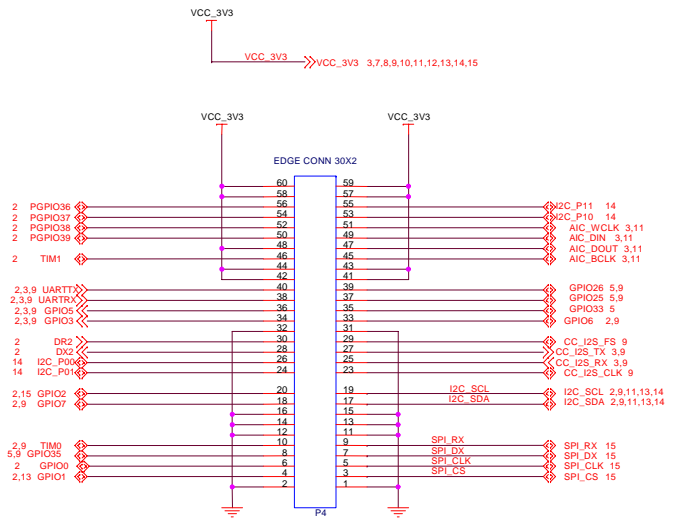

SPECTRUM DIGITAL INCORPORATED			
Title: TMS320C5502 EZDSP MODULE			
Page Contents: EXPANSION CONNECTORS			
Size: B	DWG NO	514322-0001	Revision: A
Date:	Wednesday, August 17, 2011	Sheet 16 of	17

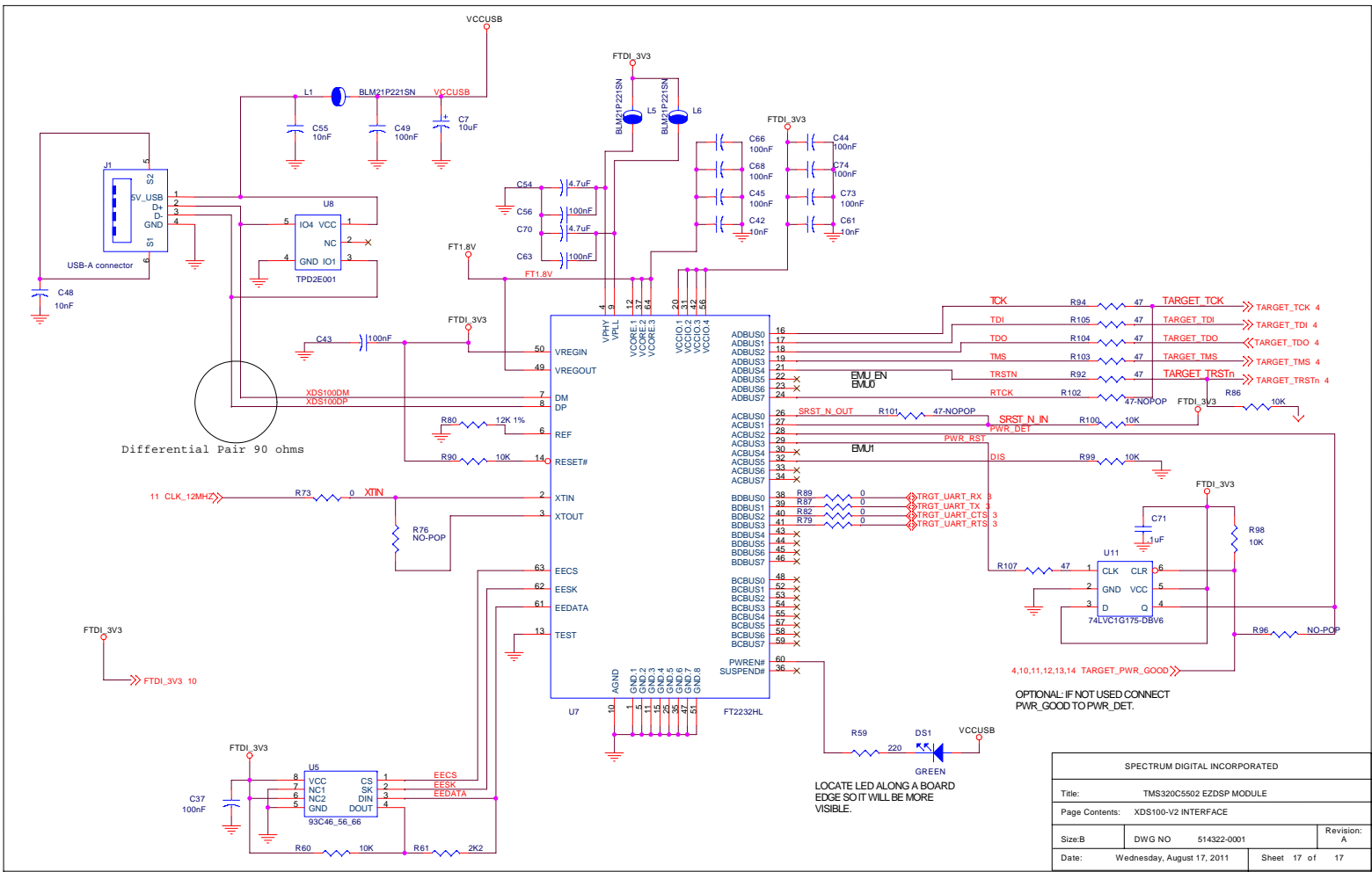

Mechanical Information

This appendix contains the mechanical information about the TMS320C5502 eZdsp produced by Spectrum Digital.

