

TMS320DM365
Evaluation Module

*Technical
Reference*

Preliminary
April 14, 2009

TMS320DM365 Evaluation Module Technical Reference

510845-0001 Rev. A
April 2009

SPECTRUM DIGITAL, INC.
12502 Exchange Drive, Suite 440 Stafford, TX. 77477
Tel: 281.494.4505 Fax: 281.494.5310
sales@spectrumdigital.com www.spectrumdigital.com

IMPORTANT NOTICE

Spectrum Digital, Inc. reserves the right to make changes to its products or to discontinue any product or service without notice. Customers are advised to obtain the latest version of relevant information to verify that the data being relied on is current before placing orders.

Spectrum Digital, Inc. warrants performance of its products and related software to current specifications in accordance with Spectrum Digital's standard warranty. Testing and other quality control techniques are utilized to the extent deemed necessary to support this warranty.

Please be aware that the products described herein are not intended for use in life-support appliances, devices, or systems. Spectrum Digital does not warrant nor is Spectrum Digital liable for the product described herein to be used in other than a development environment.

Spectrum Digital, Inc. assumes no liability for applications assistance, customer product design, software performance, or infringement of patents or services described herein. Nor does Spectrum Digital warrant or represent any license, either express or implied, is granted under any patent right, copyright, or other intellectual property right of Spectrum Digital, Inc. covering or relating to any combination, machine, or process in which such Digital Signal Processing development products or services might be or are used.

WARNING

This equipment is intended for use in a laboratory test environment only. It generates, uses, and can radiate radio frequency energy and has not been tested for compliance with the limits of computing devices pursuant to subpart J of part 15 of FCC rules, which are designed to provide reasonable protection against radio frequency interference. Operation of this equipment in other environments may cause interference with radio communications, in which case the user at his own expense will be required to take whatever measures necessary to correct this interference.

Contents

1	Introduction to the DM365 Evaluation Module	1-1
	<i>Provides you with a description of the DM365 Evaluation Module, key features, and block diagram.</i>	
1.1	Key Features	1-2
1.2	Functional Overview of the DM365 EVM	1-4
1.3	Basic Operation	1-4
1.4	Memory Map	1-5
1.5	Boot / Configuration Switch Settings	1-6
1.6	Power Supply	1-7
2	Board Components	2-1
	<i>Describes the operation of the major board components on the DM365 Evaluation Module.</i>	
2.1	EMIF Interfaces	2-2
2.1.1	Flash, NAND Flash	2-2
2.1.1.1	One NAND	2-2
2.1.1.2	CPLD Interface	2-4
2.1.1.2.1	Register 0, CPLD Version	2-6
2.1.1.2.2	Register 1, Test Register	2-6
2.1.1.2.3	Register 2, LED Register	2-6
2.1.1.2.4	Register 3, Board Mux Control Register	2-6
2.1.1.2.5	Register 4, Board Switch Register	2-7
2.1.1.2.6	Register 5, Power Control Register	2-7
2.1.1.2.7	Register 6, GPIO Video Register	2-8
2.1.1.2.8	Register 7, Media Card Status	2-9
2.1.1.2.9	Register 8, DILC Output Pin Mapping	2-9
2.1.1.2.10	Register 9, DILC Input Pin Mapping	2-10
2.1.1.2.11	Register 10, Imager Internal I/O Direction Register 0	2-10
2.1.1.2.12	Register 11, Internal I/O Mux Register 0	2-11
2.1.1.2.13	Register 12, Internal I/O Mux Register 1	2-11
2.1.1.2.14	Register 13, Imager Internal I/O Direction Register 1	2-12
2.1.1.2.15	Register 14, Imager Internal I/O Mux Register 2	2-12
2.1.1.2.16	Register 15, Imager Internal I/O Mux Register 3	2-13
2.1.1.2.17	Register 16, Imager Internal I/O Direction Register 2	2-13
2.1.1.2.18	Register 17, Imager Internal I/O Mux Register 4	2-14
2.1.1.2.19	Register 18, Imager Internal I/O Mux Register 5	2-14
2.1.1.2.20	Register 19, Board RESET Register	2-15
2.1.1.2.21	Register 720, CCD Internal I/O Direction Register 1	2-15
2.1.1.2.22	Register 721, CCS Internal I/O Read/Write Register 1	2-16
2.1.1.2.23	Register 722, CCD Internal I/O Direction Register 2	2-16
2.1.1.2.24	Register 723, CCD Internal I/O Read/Write Register 2	2-17
2.1.1.2.25	Register 724, CCD Internal I/O Direction Register 3	2-17

2.1.1.2.26 Register 725, CCD Internal I/O Read/Write Register 3	2-18
2.1.1.3 Key Pad Interface	2-19
2.1.2 DDR2 Memory Interface	2-19
2.1.3 Media Card Interface	2-19
2.1.4 UART Interface	2-20
2.1.5 USB Interface	2-20
2.2 Input Video Port/Imager Input Port Interfaces	2-20
2.2.1 On Chip Video Output DAC	2-21
2.2.2 LCD Video Connectors	2-21
2.3 AIC3101 Interface	2-22
2.4 On Chip Voice Codec	2-23
2.5 On Chip ADC	2-23
2.6 On Chip RTC	2-23
2.7 Ethernet Interface	2-24
2.8 I ² C Interface	2-24
2.8.1 MSP430	2-25
2.9 Daughter Card Interface	2-25
2.10 DM365 CPU Video Clocks	2-25
2.11 Battery	2-26
3 Physical Specifications	3-1
<i>Describes the physical layout of the DM365 Evaluation Module and its connectors.</i>	
3.1 Board Layout	3-3
3.2 Connectors	3-5
3.2.1 J1, MiniAB USB Connector and Jumpers	3-6
3.2.2 J2, 14 Pin External JTAG Header	3-7
3.2.3 J3, MSP430 JTAG Header	3-8
3.2.4 J4, Spare Jumper Holder	3-8
3.2.5 J5, 20 Pin ARM JTAG Emulation Header	3-9
3.2.6 J6, USB Capacitance Select	3-9
3.2.7 J7, +5 Volts Input	3-10
3.2.8 J12, SD/MMC/MS Card Interface	3-10
3.2.9 J10, Imager Interface	3-11
3.2.10 J14, EMIF/UPI DC Interface	3-12
3.2.11 J8, Y Component Video In, RCA Jack (Green)	3-13
3.2.12 J9, Pb Component Video In, RCA Jack (Blue)	3-13
3.2.13 J11, Pr Component Video In, RCA Jack (Red)	3-14
3.2.14 J15, S-Video In	3-14
3.2.15 J13, CVBS/Y Input, RCA Jack (Yellow)	3-15
3.2.16 J16, Composite TV Out, RCA Jack (Yellow)	3-15
3.2.17 J17, Y Component Video Out, RCA Jack (Green)	3-16
3.2.18 J20, Pb Component Video Out, RCA Jack (Blue)	3-16
3.2.19 J21, Pr Component Video Out, RCA Jack (Red)	3-17
3.2.20 J18, J19, Video Output DC	3-18
3.2.21 J22, CPLD Programming Header	3-19
3.2.22 J23, I/O Interface Header	3-19
3.2.23 J24, DILC Host Connector	3-20
3.2.24 J25, MMC/SD Connector	3-21
3.2.25 P1, RS-232 UART	3-22
3.2.26 P2, Ethernet Interface	3-23

3.2.27	P3, Microphone In	3-24
3.2.28	P4, Line In	3-24
3.2.29	P5, Line Out	3-25
3.2.30	P6, Headphone Out	3-25
3.2.31	U1, Infrared Interface	3-26
3.2.32	SPK1, Speaker Interface	3-26
3.2.33	BHT1, Battery Interface	3-27
3.2.34	M1, Microphone Interface	3-27
3.3	LEDs	3-28
3.4	Switches	3-29
3.4.1	SW1, EMU0/1 Select Switch	3-30
3.4.2	SW2, PWCTRO0 Pushbutton	3-30
3.4.3	SW3, Non-Supported Pushbutton	3-30
3.4.4	SW4, Boot Mode / Configuration Select	3-31
3.4.5	SW5, Board Configuration Select	3-32
3.4.6	SW6 - SW21, Function Pushbuttons	3-32
3.4.7	SW22, MSP430 IO0 Pushbutton	3-33
3.4.8	SW23, PRTSC Mode Select	3-33
3.5	Jumpers	3-34
3.5.1	JP1, Jumper Block	3-34
3.6	Test Points	3-35
A	Schematics	A-1
	<i>Contains the schematics for the DM365 Evaluation Module</i>	
B	Mechanical Information	B-1
	<i>Contains the mechanical information about the DM365 Evaluation Module</i>	

About This Manual

This document describes the board level operations of the DM365 Evaluation Module (EVM). The EVM is based on the Texas Instruments TMS320DM365 Processor.

The DM365 Evaluation Module is a table top card that allows engineers and software developers to evaluate certain characteristics of the DM365 processor to determine if the processor meets the designers application requirements. Evaluators can create software to execute on board or expand the system in a variety of ways.

Notational Conventions

This document uses the following conventions.

The DM365 Evaluation Module will sometimes be referred to as the DM365 EVM or EVM.

Program listings, program examples, and interactive displays are shown in a special italic typeface. Here is a sample program listing.

```
equations  
!rd = !strobe&rw;
```

Information About Cautions

This book may contain cautions.

This is an example of a caution statement.

A caution statement describes a situation that could potentially damage your software, or hardware, or other equipment. The information in a caution is provided for your protection. Please read each caution carefully.

Related Documents, Application Notes and User Guides

Information regarding the TMS320DM365 can be found at the following Texas Instruments website:

<http://www.ti.com>

Table 1: Manual History

Revision	History
A	Beta Release

Table 2: Board History

PWB Revision	History
C	Beta Release

Chapter 1

Introduction to the DM365 EVM

Chapter One provides a description of the DM365 EVM along with the key features and a block diagram of the circuit board.

Topic	Page
1.1 Key Features	1-2
1.2 Functional Overview of the DM365 EVM	1-4
1.3 Basic Operation	1-4
1.4 Memory Map	1-5
1.5 Boot / Configuration Switch Settings	1-6
1.6 Power Supply	1-7

- 2 Gigabytes NAND Flash
- 128 Megabytes of One NAND
- AIC3101 stereo codec
- USB2 Interface
- 10/100 MBS RMII Ethernet Interface
- SPI EEPROM
- IR Remote Interface via MSP430
- Configurable boot load options
- 8 user LEDs/16 user push button switches
- Single voltage power supply (+5V)
- Expansion connectors for daughter card use
- 14 Pin TI JTAG/20 Pin ARM JTAG Interfaces

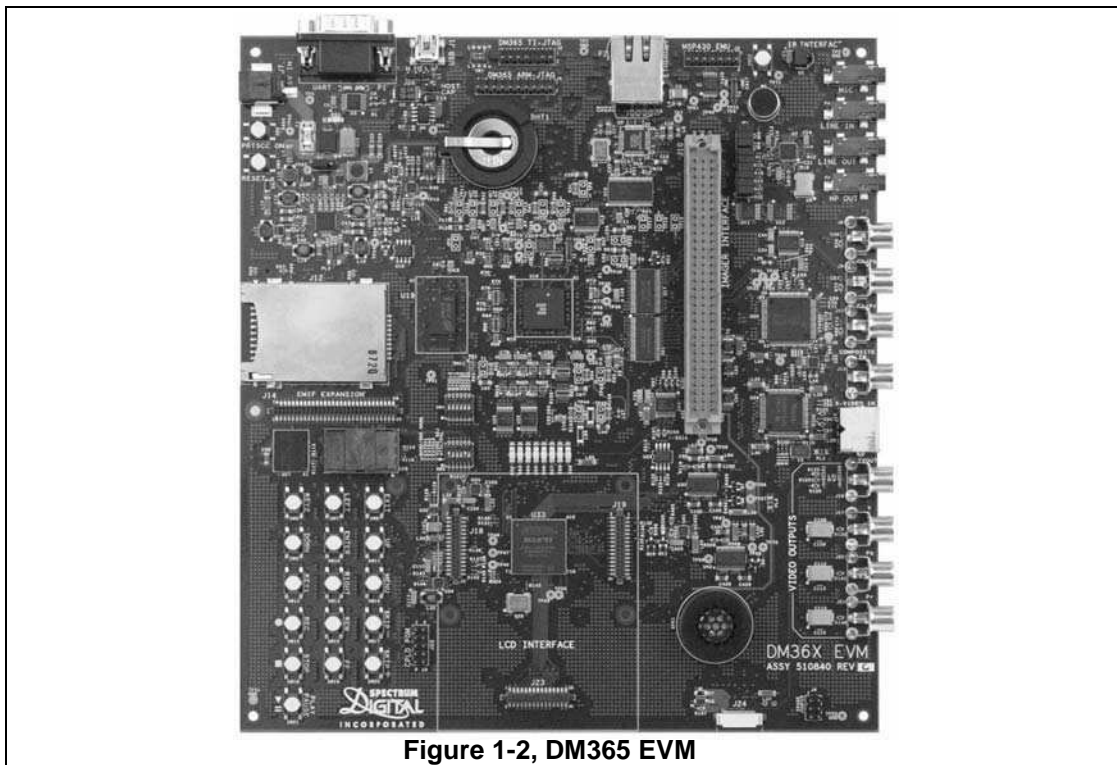

1.2 Functional Overview of the DM365 EVM

The DM365 on the EVM interfaces to on-board peripherals through the 8/16-bit wide Async EMIF peripheral interface pins. The DDR2 memory is connected to its own dedicated 16 bit wide bus. The Async EMIF bus is also connected to the NAND and One NAND flash.

On board video decoders and on chip encoders interface video streams to the DM365 processor. One composite channel and one set of 3 component channel encoder/decoder are standard on the EVM. On screen display functions are implemented in software on the DM365 processor.

An on-board AIC3101 codec allows the DSP to transmit and receive analog audio signals. The I²C bus is used for the codec control interface, while the McBSP controls the audio stream. Signal interfacing is done through 3.5mm audio jacks that correspond to microphone input, headphone output, line input, and line output.

The EVM includes 8 user LEDs, 16 user push button switches, and an IR interface which provide the user with application interaction.

An included +5V external power supply is used to power the board. On-board switching voltage regulators provide the +1.2 to 1.35V CPU core voltage, +3.3V for peripherals and +1.8V for DDR2 memory.

The DM365 EVM has a 10/100 ethernet interface which provides a standard high speed link to other devices.

The on board media card interface allows the user to conveniently load/store data from a variety of standard memory card formats. An on-chip Real Time Clock is integrated into the DM365 for time based applications.

1.3 Basic Operation

The EVM is designed to work with TI's Code Composer Studio IDE[™], or standard GDB tool environments. Code Composer communicates with the board through an external JTAG emulator.

1.4 Memory Map

The DM365 processor has a byte addressable address space. There are some limitations to byte addressing which are determined by peripheral interconnection to the DM365 device. Program code and data can be placed anywhere in the unified address space. Addresses are multiple sizes depending on hardware implementation. Refer to the appropriate device data sheets for more details.

The memory map shows the address space of a generic DM365 processor on the left with specific details of how each region is used on the right. By default, the internal memory sits at the beginning of the address space. Portions of memory can be remapped in software as L2 cache rather than fixed RAM.

The part incorporates a dual EMIF interface. One dedicated EMIF directly interfaces to the DDR2 memory. The other EMIF has 2 separate addressable regions called chip enable spaces (CE0 & CE1). The NAND Flash, one NAND, and CPLD are mapped into these chip enable spaces.

DM365 EVM	
Address	Memory Map Address Space
0x00000000	ARM Instruction RAM
0x00007FFF 0x00008000	ARM Instruction ROM
0x0000BFFF 0x00010000	ARM RAM (Data)
0x00017FFF 0x01C00000	CFG Bus Peripherals
0x01FFFFFF 0x02000000	CE0 - ASYNC EMIF (Data)
0x03FFFFFF 0x04000000	CE1
0x05FFFFFF 0x20000000	DDR EMIF Control Regs
0x2007FFFF 0x80000000	DDR EMIF
0x87FFFFFF 0x88000000	DDR Expansion (reserved)
0x8FFFFFFF	

Figure 1-3, Memory Map, DM365 EVM

Shown below is a break out of the memory spaces.

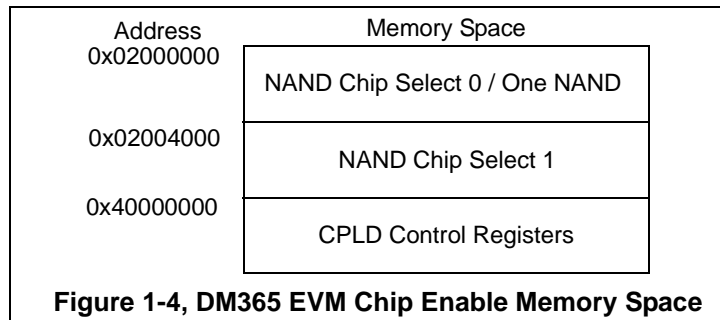

1.5 Boot / Configuration Switch Settings

The EVM has a configuration switch that allow users to control the Boot and EMIF configuration state of the processor when it is released from reset. The switch SW4 determines the source for processor booting. By default the switches are configured to NAND Flash boot. The EMIF configuration switch must be set accordingly. This switch configures the DM365 pin muxing at RESET. The default for the pin muxing is shown below. For additional pin muxing requirements please refer to the D365 data sheet.

Table 1: SW4, ARM Boot Mode Select

Pos 3	Pos 2	Pos 1	HW Code	Boot Mode
ON	ON	ON	0 0 0	NAND Boot *
ON	ON	OFF	0 0 1	ASYNC EMIF
ON	OFF	ON	0 1 0	MMC/SD Boot
ON	OFF	OFF	0 1 1	UART Boot
OFF	ON	ON	1 0 0	USB Boot
OFF	ON	OFF	1 0 1	SPI Boot
OFF	OFF	ON	1 1 0	EMAC Boot
OFF	OFF	OFF	1 1 1	HPI Boot

Table 2: SW4, ARM EMIF Configuration Mode Select

Pos 6	Pos 5	Pos 4	HW Code	Configuration Mode
ON	ON	ON	0 0 0	8-bit AEMIF Configuration *
ON	ON	OFF	0 0 1	16-bit AEMIF Configuration

* default setting

1.6 Power Supply

The EVM operates from a single +5V external power supply connected to the main power input (J7), a 2.5 MM. barrel-type plug. Internally, the +5V input is converted into +1.2 to 1.35V, +1.8V and +3.3V using Texas Instruments TPS65530 power management IC and various linear regulators. The +1.2 to 1.35V supply is used for the DSP core while the +3.3V supply is used for the DSP's I/O buffers and other chips on the board. The +1.8 volt supply is used for DM365 DDR2 memory, and other on chip peripherals.

Chapter 2

Board Components

This chapter describes the operation of the major board components on the DM365 EVM.

Topic	Page
2.1 Asynchronous EMIF Interface	2-2
2.1.1 NAND Flash	2-2
2.1.1.1 One NAND	2-2
2.1.1.2 CPLD Interface	2-4
2.1.1.2.1 Register 0, CPLD Version	2-6
2.1.1.2.2 Register 1, Test Register	2-6
2.1.1.2.3 Register 2, LED Register	2-6
2.1.1.2.4 Register 3, Board Mux Control Register	2-6
2.1.1.2.5 Register 4, Board Switch Register	2-7
2.1.1.2.6 Register 5, Power Control Register	2-7
2.1.1.2.7 Register 6, GPIO Video Register	2-8
2.1.1.2.8 Register 7, Media Card Status	2-9
2.1.1.2.9 Register 8, DILC Output Pin Mapping	2-9
2.1.1.2.10 Register 9, DILC Input Pin Mapping	2-10
2.1.1.2.11 Register 10, Imager Internal I/O Direction Register 0	2-10
2.1.1.2.12 Register 11, Internal I/O Mux Register 0	2-11
2.1.1.2.13 Register 12, Internal I/O Mux Register 1	2-11
2.1.1.2.14 Register 13, Imager Internal I/O Direction Register 1	2-12
2.1.1.2.15 Register 14, Imager Internal I/O Mux Register 2	2-12
2.1.1.2.16 Register 15, Imager Internal I/O Mux Register 3	2-13
2.1.1.2.17 Register 16, Imager Internal I/O Direction Register 2	2-13
2.1.1.2.18 Register 17, Imager Internal I/O Mux Register 4	2-14
2.1.1.2.19 Register 18, Imager Internal I/O Mux Register 5	2-14
2.1.1.2.20 Register 19, Board RESET Register	2-15
2.1.1.2.21 Register 720, CCD Internal I/O Direction Register 1	2-15
2.1.1.2.22 Register 721, CCS Internal I/O Read/Write Register 1	2-16
2.1.1.2.23 Register 722, CCD Internal I/O Direction Register 2	2-16
2.1.1.2.24 Register 723, CCD Internal I/O Read/Write Register 2	2-17
2.1.1.2.25 Register 724, CCD Internal I/O Direction Register 3	2-17
2.1.1.2.26 Register 725, CCD Internal I/O Read/Write Register 3	2-18

Topic	Page
2.1.1.3 Key Pad Interface	2-19
2.1.2 DDR2 Memory Interface	2-19
2.1.3 Media Card Interface	2-19
2.1.4 UART Interface	2-20
2.1.5 USB Interface	2-20
2.2 Input Video Port/Imager Input Port Interfaces	2-20
2.2.1 On Chip Video Output DAC	2-21
2.2.2 LCD Video Connectors	2-21
2.3 AIC3101 Interface	2-22
2.4 On Chip Voice Codec	2-23
2.5 On Chip ADC	2-23
2.6 On Chip RTC	2-23
2.7 Ethernet Interface	2-24
2.8 I ² C Interface	2-24
2.8.1 MSP430	2-25
2.9 Daughter Card Interface	2-25
2.10 DM365 CPU/Video Clocks	2-25
2.11 Battery	2-26

2.1 Asynchronous EMIF Interface

An asynchronous 16 bit EMIF with two chip enables divide up the address space and allow for asynchronous accesses on the EVM. This interface connects to the NAND, One NAND, and CPLD registers on the EVM board.

2.1.1 NAND Flash

The DM365 has 2 gigabytes of NAND Flash memory mapped into the CE0 space. The NAND Flash memory is used primarily for boot loading and file system on the DM365 EVM. The CE0 selects the device and needs to be configured to 8 bits wide when accessing the NAND.

Switch SW5, position 1 (OFF) selects CE0 mapped to NAND. The NAND and One NAND interface share the same CE0 chip select so only 1 device can be operational at any given time.

When the NAND flash interface is selected the spare address lines can be used by the internal DM365 key pad interface. This interface is enabled by setting a control bit in the CPLD to enable the on board CBTLV switches to the keypad matrix.

2.1.1.1 One NAND

The EVM supports 128 Megabytes of One NAND. This interface is 16 bits wide and CE0 must be configured for 16 bit wide operation when using One NAND. Switch SW5, position 1 (ON) selects the One NAND device. When the One NAND is selected the on board NAND is not available. Since the One NAND uses all the asynchronous EMIF address lines the on-chip key pad controller on the DM365 cannot be used when the One NAND is selected.

2.1.1.2 CPLD Interface

The DM365 incorporates an Altera EPM2210, 256 Ball Grid Array(BGA) CPLD. The CPLD incorporates a number of internal registers, glue logic, and I/O multiplexing to allow for a very flexible development platform. The CPLD is accessed via EMIF CE1. The interface is 8 bits wide. All registers show up as 4 mirror images in the memory window due to 32 bit addressing and 8 bit data mapping, that is BA0 and BA1 are not used in the memory decoder for registers.

Address lines A7-A3 and BA0 and BA1 are not used in the decoder so that these lines can be used by the keypad decoder.

The base address of CE1 is 0x0400 0000. Each additional register is accessed on an increment of 0x0000 0008. The addresses are in the following format:
A13, A12, A11, A10, A9, A8, Ax, Ax, Ax, Ax, Ax, A2, A1, Ax, Ax.

The following sections describe the registers and their function. A list of the registers is shown in the table below.

Table 1: CPLD Registers

Reg #	Address A13 - A8	Address A2-A1	Function	R/W
0	0 0 0 0 0 0	0 0	CPLD Version	R
1	0 0 0 0 0 0	0 1	Test Register	R,W
2	0 0 0 0 0 0	1 0	LED Register	R,W
3	0 0 0 0 0 0	1 1	Board Mux Control	R,W
4	0 0 0 0 0 1	0 0	Board Switch Register	R
5	0 0 0 0 0 1	0 1	Power Control Register	R,W
6	0 0 0 0 0 1	1 0	GPIO Video Register	R,W
7	0 0 0 0 0 1	1 1	Media Card Status	R
8	0 0 0 0 1 0	0 0	DILC Output Pin Mapping	R,W
9	0 0 0 0 1 0	0 1	DILC Input Pin Mapping	R
10	0 0 0 0 1 0	1 0	Imager Internal I/O Direction Register 0	R,W
11	0 0 0 0 1 0	1 1	Imager Internal I/O Mux Register 0	R,W
12	0 0 0 0 1 1	0 0	Imager Internal I/O Mux Register 1	R,W
13	0 0 0 0 1 1	0 1	Imager Internal I/O Direction Register 1	R,W
14	0 0 0 0 1 1	1 0	Imager Internal I/O Mux Register 2	R,W
15	0 0 0 0 1 1	1 1	Imager Internal I/O Mux Register 3	R,W
16	0 0 0 1 0 0	0 0	Imager Internal I/O Direction Register 2	R,W
17	0 0 0 1 0 0	0 1	Imager Internal I/O Mux Register 4	R,W
18	0 0 0 1 0 0	1 0	Imager Internal I/O Mux Register 5	R,W
19	0 0 0 1 0 0	1 1	Board RESET Register	R,W
720	1 1 1 1 1 0	0 0	CCD Internal I/O Direction Register 1	R,W
721	1 1 1 1 1 0	0 1	CCD Internal I/O Read/Write Register 1	R,W
722	1 1 1 1 1 0	1 0	CCD Internal I/O Direction Register 2	R,W
723	1 1 1 1 1 0	1 1	CCD Internal I/O Read/Write Register 2	R,W
724	1 1 1 1 1 1	0 0	CCD Internal I/O Direction Register 3	R,W
725	1 1 1 1 1 1	0 1	CCD Internal I/O Read/Write Register 3	R,W

2.1.1.2.1 Register 0, CPLD Version

This read only, 8 bit register, contains the CPLD hardware version for version control. The default value is 0x11.

2.1.1.2.2 Register 1, Test Register

This read only, 8 bit register, has a default value of 0xA5 and can be read and written to test the memory interface.

2.1.1.2.3 Register 2, LED Register

This 8 bit, read/write register controls the user LEDs. A data bit of ‘0’ in each bit location turns on an LED. Similarly a ‘1’ turns off the LED in each bit position.

2.1.1.2.4 Register 3, Board Mux Control Register

This 8 bit, read/write control register (default = 0x00) controls keypad, AIC, SD, Ethernet, and Video In multiplexers as shown in the table below.

points as shown in the table below.

Table 2: Register 3, Board Mux Control Register

Bit #	Signal	State	Function
7	EMIF_KEYPAD_CTL	0	Addresses on Muxes (ONE NAND Mode)
		1	Addresses are available for keypad
6	SEL_SD1_GPIO_CTL	0	Enables SD card slot 1
		1	Signals for SD1 card slot 1 go to CPLD imager GPIO
5	SEL_AICn_GPIO_CTL	0	Enables McBSP signals to AIC3101 codec
		1	McBSP signals go to CPLD for imager GPIO
4	Spare		Not currently used
3	SEL_ENET_GPIO_CTL	0	Enable Ethernet signals to PHY
		1	Ethernet signals go to CPLD for imager GPIO
2	DECODER_IMAGER_S2_CTL	S[2:0]	0 0 1 = Selects TVP7002 as input to DM365 video input port 0 1 0 = Selects imager as input to DM365 video input port 1 0 1 = Selects TVP5146 as input to DM365 video input port
1	DECODER_IMAGER_S1_CTL		
0	DECODER_IMAGER_S0_CTL		

2.1.1.2.5 Register 4, Board Switch Register

This 8 bit, read only register mirrors the values set on switch SW5. These signals are shown in the table below.

Table 3: Register 4, Board Switch Register

Bit #	SW5 Position	Signal
7	Reserved	N/A
6	Reserved	N/A
5	1	SEL_NAND_LOW 0 = NAND mapped to CE0, 1 = ONE NAND mapped to CE0
4	2	SEL_EXTRA1
3	3	SEL_EXTRA2
2	4	SEL_EXTRA3
1	5	CPU_VSEL1 0 = Vcore at 1.2V 1 = Vcore at 1.35 V
0	6	SEL_NTAS_MODE

2.1.1.2.6 Register 5, Power Control Register

Register 5 is a 8 bit, read/write register that controls on board voltage regulator functions. The default data value is 0b00000000. These controls are shown in the table below.

Table 4: Register 5, Power Control Register

Bit #	Signal	Function
7	LCD_OE_5V	0,1 = Sets U32 FDC6331L Pin to 0,1
6	ENABLE_LCD_3V3	0 = Disables U31 TPS74701 1 = Enables U31 TPS74701
5	Reserved	
4	EN7	0,1 = Sets U14 TPS65530 EN7 pin to 0,1
3	ENAFE	0,1 = Sets U14 TPS65530 ENAFE pin to 0,1
2	SEQ56	0,1 = Sets U14 TPS65530 SEQ56 pin to 0,1
1	EN56	0,1 = Sets U14 TPS65530 EN56 pin to 0,1
0	ENABLE_LCD_15V	0 = Disables U34 TPS61080 register 1 = Enables U34 TPS61080 register

2.1.1.2.7 Register 6, GPIO Video Register

Register 6 is a 8 bit, read/write register that controls the mapping of GPIO30/32/33, VDIN_WE, DRV_BUS. The default data value is 0b00000000. These controls are shown in the table below.

Table 5: Register 6, GPIO Video Register

Bit #	Signal	Function
7	Reserved	
6	Reserved	
5	C_FIELD	1 = DM365 Ball E13 mapped to EXP CONN CCD_FIELD
4	C_WE	1 = DM365 Ball E13 mapped to EXP CONN CCD_WEN
3	24 BIT COLOR	1 = Map GPIO30,32,33 to G1,R0,R1 on LCD EXP CONNS
2	C_WE_FLD_VBUS_DRV	1 = DM365 BALL E13 Drives U4, TPS2065
1	GIO33_VBUS_DRV	1 = GIO33 drives U4, TPS2065
0	VBUS_DRV_ALT	1 = Drives VBUS ENABLE to U4, TPS2065

ENABLE VBUS_DRV (U4, TPS2065) will = 1 when any of the following occur:

- When SW5-2 (SEL_EXTRA1_ = 1 for test
- When VBUS_DRV_ALT = 1

ENABLE VBUS_DRV (U4, TPS2065) will = DM365 GIO33 when
GIO33_VBUS_DRV = 1

ENABLE VBUS_DRV (U4, TPS2065) will = DM365 Ball E13 when
C_WE_FLD_VBUS_DRV = 1

2.1.1.2.8 Register 7, Media Card Status

Register 7 is a 8 bit, read only register that reads the “Insert” and “Write Protect” status of media cards. These functions of these bits are shown in the table below.

Table 6: Register 7, Media Card Status

Bit #	Signal	Function
7	Reserved	Reads 0
6	Reserved	Reads 0
5	SD_MMC_1 WRITE PROTECT	0 = Write Protect
4	SD_MMC_1 INSERT	0 = Insert
3	Reserved	Reads 0
2	SD_MMC0 MS INSERT	0 = Insert
1	SD_MMC_0 WRITE PROTECT	0 = Write Protect
0	SD_MMC_0 INSERT	0 = Insert

2.1.1.2.9 Register 8, DILC Output Pin Mapping

Register 8 is a 8 bit, read/write register that maps DM365 GPIO and SPI2 pins to the DILC connector. The default data value is 0b11111111. The mapping of these pins is shown in the table below.

Table 7: Register 8, DILC Output Pin Mapping

Bit #	Signal	Function
7	DILC_DRV_VBUS	Register drives DILC DRV_VBUS pin when bit 6 = 0
6	DILC_DRV_VBUS_IO	0 = Internal register bit 7 drives DILC pin
5	DILC_VBUS_DET_DRV	Register drives DILC pin VBUS_DET when bit 4 = 0
4	DILC_VBUS_DET_IO	0 = Internal register bit 5 drives DILC pin
3	Reserved	N/A
2	CPU_GPIO32_IO	0 = IN, SPI2_DILC drives GIO32 1 = OUT, GIO32 drives SPI2_DILC
1	CPU_GPIO31_IO	0 = IN, SPI2_DILC drives GIO31 1 = OUT, GIO31 drives SPI2_DILC
0	CPU_GPIO30_IO	0 = IN, SPI2_DILC drives GIO30 1 = OUT, GIO30 drives SPI2_DILC

2.1.1.2.10 Register 9, DILC Input Pin Mapping

Register 9 is a 8 bit, read only register that maps DILC pins to read contents on this register. The mapping of these pins is shown in the table below.

Table 8: Register 9, DILC Input Pin Mapping

Bit #	Function
7	Reserved
6	Reads value of DILC connector pin GIO_DILC_DRV_VBUS1
5	Reads value of DILC connector pin GIO_DILC_DRV_DET
4	Reserved
3	Reads value of DILC connector pin GIO_DILC_DOCK_DET
2	Reads value of DILC connector pin GIO_DILC_CAM_PWR_DECT
1	Reads value of DILC connector pin GIO_DILC_AVJ_DET
0	Reads value of DILC connector pin GIO_DILC_CHG_CTL

2.1.1.2.11 Register 10, Imager Internal I/O Direction Register 0

Register 10 is a 8 bit, read/write register that controls DM365 GPIO to IMAGER connector pin input/output mapping. The default data value is 0b11111111. This mapping is shown in the table below.

Table 9: Register 10, Imager Internal I/O Direction Register 0

Bit #	Function	Mapping
7	0 = GPIO_MD8 to DM365 pin	0 = Outputs 1 = DM365 pins are inputs
6	0 = GPIO_MD7 to DM365 pin	0 = Outputs 1 = DM365 pins are inputs
5	0 = GPIO_MD6 to DM365 pin	0 = Outputs 1 = DM365 pins are inputs
4	0 = GPIO_MD5 to DM365 pin	0 = Outputs 1 = DM365 pins are inputs
3	0 = GPIO_MD4 to DM365 pin	0 = Outputs 1 = DM365 pins are inputs
2	0 = GPIO_MD3 to DM365 pin	0 = Outputs 1 = DM365 pins are inputs
1	0 = SPI4_SDI_GPIO_MD2 to DM365 pin	0 = Outputs 1 = DM365 pins are inputs
0	0 = GPIO_MD1 to DM365 pin	0 = Outputs 1 = DM365 pins are inputs

2.1.1.2.12 Register 11, Internal I/O Mux Register 0

Register 11 is a 8 bit, read/write register that controls DM365 GPIO Muxing to IMAGER connector pin input. The default data is 0b00000000. The table below shows this muxing.

Table 10: Register 11, Internal I/O Mux Register 0

Bit #	Muxing
7	0 = GPIO_MD4 MUX SELB
6	0 = GPIO_MD4 MUX SELA
5	0 = GPIO_MD3 MUX SELB
4	0 = GPIO_MD3 MUX SELA
3	0 = SPI4_SDI_GPIO_MD2 MUX SELB
2	0 = SPI4_SDI_GPIO_MD2 MUX SELA
1	0 = GPIO_MD1 MUX SELB
0	0 = GPIO_MD1 MUX SELA

2.1.1.2.13 Register 12, Internal I/O Mux Register 1

Register 12 is a 8 bit, read/write register that controls DM365 GPIO Muxing to IMAGER connector pin input. The default data is 0b00000000. The table below shows this muxing.

Table 11: Register 12, Internal I/O Mux Register 1

Bit #	Muxing
7	0 = GPIO_MD8 MUX SELB
6	0 = GPIO_MD8 MUX SELA
5	0 = GPIO_MD7 MUX SELB
4	0 = GPIO_MD7 MUX SELA
3	0 = GPIO_MD6 MUX SELB
2	0 = GPIO_MD6 MUX SELA
1	0 = GPIO_MD5 MUX SELB
0	0 = GPIO_MD5 MUX SELA

2.1.1.2.14 Register 13, Imager Internal I/O Direction Register 1

Register 13 is a 8 bit, read/write register that controls DM365 GPIO to IMAGER connector pin input/output mapping. The default data is 0b00000000. This mapping is shown in the table below.

Table 12: Register 13, Imager Internal I/O Direction Register 1

Bit #	Function	Mapping
7	0 = GPIO_MD16 to DM365 pin	0 = Outputs 1 = DM365 pins are inputs
6	0 = GPIO_MD15 to DM365 pin	0 = Outputs 1 = DM365 pins are inputs
5	0 = GPIO_MD14 to DM365 pin	0 = Outputs 1 = DM365 pins are inputs
4	0 = GPIO_MD13 to DM365 pin	0 = Outputs 1 = DM365 pins are inputs
3	0 = GPIO_MD12 to DM365 pin	0 = Outputs 1 = DM365 pins are inputs
2	0 = GPIO_MD11 to DM365 pin	0 = Outputs 1 = DM365 pins are inputs
1	0 = GPIO_MD10 to DM365 pin	0 = Outputs 1 = DM365 pins are inputs
0	0 = GPIO_MD9 to DM365 pin	0 = Outputs 1 = DM365 pins are inputs

2.1.1.2.15 Register 14, Imager Internal I/O Mux Register 2

Register 14 is a 8 bit, read/write register that controls DM365 GPIO Muxing to IMAGER connector pin input. The default data is 0b00000000. The table below shows this muxing.

Table 13: Register 12, Imager Internal I/O Mux Register 2

Bit #	Muxing
7	0 = GPIO_MD12 MUX SELB
6	0 = GPIO_MD12 MUX SELA
5	0 = GPIO_MD11 MUX SELB
4	0 = GPIO_MD11 MUX SELA
3	0 = GPIO_MD10 MUX SELB
2	0 = GPIO_MD10 MUX SELA
1	0 = GPIO_MD9 MUX SELB
0	0 = GPIO_MD9 MUX SELA

2.1.1.2.16 Register 15, Imager Internal I/O Mux Register 3

Register 14 is a 8 bit, read/write register that controls DM365 GPIO Muxing to IMAGER connector pin input. The default data is 0b00000000. The table below shows this muxing.

Table 14: Register 15, Imager Internal I/O Mux Register 3

Bit #	Muxing
7	0 = GPIO_MD16 MUX SELB
6	0 = GPIO_MD16 MUX SELA
5	0 = GPIO_MD15 MUX SELB
4	0 = GPIO_MD15 MUX SELA
3	0 = GPIO_MD14 MUX SELB
2	0 = GPIO_MD14 MUX SELA
1	0 = GPIO_MD13 MUX SELB
0	0 = GPIO_MD13 MUX SELA

2.1.1.2.17 Register 16, Imager Internal I/O Direction Register 3

Register 16 is a 8 bit, read/write register that controls DM365 GPIO to IMAGER connector pin input/output mapping. The default data is 0b00000000. This mapping is shown in the table below.

Table 15: Register 16, Imager Internal I/O Direction Register 3

Bit #	Function	Mapping
7	Reserved	
6	0 = CCD_DDS_RST to DM365 pin	0 = Outputs 1 = DM365 pins are inputs
5	0 = PWM_CCD_SUB to DM365 pin	0 = Outputs 1 = DM365 pins are inputs
4	0 = GPIO_TACH to DM365 pin	0 = Outputs 1 = DM365 pins are inputs
3	0 = GPIO_MST_SLV to DM365 pin	0 = Outputs 1 = DM365 pins are inputs
2	0 = GPIO_MD19 to DM365 pin	0 = Outputs 1 = DM365 pins are inputs
1	0 = GPIO_MD18 to DM365 pin	0 = Outputs 1 = DM365 pins are inputs
0	0 = GPIO_MD17 to DM365 pin	0 = Outputs 1 = DM365 pins are inputs

2.1.1.2.18 Register 17, Imager Internal I/O Mux Register 4

Register 17 is a 8 bit, read/write register that controls DM365 GPIO Muxing to IMAGER connector pin input. The default data is 0b00000000. The table below shows this muxing.

Table 16: Register 17, Imager Internal I/O Mux Register 4

Bit #	Muxing
7	0 = GPIO__MST_SLV MUX SELB
6	0 = GPIO__MST_SLV MUX SELA
5	0 = GPIO_MD19 MUX SELB
4	0 = GPIO_MD19 MUX SELA
3	0 = GPIO_MD18 MUX SELB
2	0 = GPIO_MD18 MUX SELA
1	0 = GPIO_MD17 MUX SELB
0	0 = GPIO_MD17 MUX SELA

2.1.1.2.19 Register 18, Imager Internal I/O Mux Register 5

Register 18 is a 8 bit, read/write register that controls DM365 GPIO Muxing to IMAGER connector pin input. The default data is 0b00000000. The table below shows this muxing.

Table 17: Register 17, Imager Internal I/O Mux Register 5

Bit #	Muxing
7	Reserved
6	Reserved
5	0 = CCD_DDS_RST MUX SELB
4	0 = CCD_DDS_RST MUX SELA
3	0 = PWM_CCD_SUB MUX SELB
2	0 = PWM_CCD_SUB MUX SELA
1	0 = GPIO_TACH MUX SELB
0	0 = GPIO_TACH MUX SELA

2.1.1.2.20 Register 19, Board RESET Register

Register 19 is a 8 bit, read/write register that allows the user to select reset to major external peripherals. The default data is 0b00000000. The table below shows the mapping of these bits.

Table 18: Register 19, Board RESET Register

Bit #	RESET Signal	State Action
7	Reserved	N/A
6	Reserved	N/A
5	Reserved	N/A
4	Reserved	N/A
3	ETHERNET_RESET	1 = Force Reset to Logic 0 0 = Map Reset to CPLD inputs
2	TVP7002_RESET	1 = Force Reset to Logic 0 0 = Map Reset to CPLD inputs
1	IC3106_RESET	1 = Force Reset to Logic 0 0 = Map Reset to CPLD inputs
0	TVP5146_RESET	1 = Force Reset to Logic 0 0 = Map Reset to CPLD inputs

2.1.1.2.21 Register 720, CCD Internal I/O Direction Register 1

Register 720 is a 8 bit, read/write register that controls CPLD GPIO to CCD Connector pin input/output mapping. The default data is 0b11111111. The table below shows the mapping of these bits.

Table 19: Register 720, CCD Internal I/O Direction Register 1

Bit #	Signal	State Action
7	0 = GPIO_0.7DIR	0 = Outputs, 1 = Inputs
6	0 = GPIO_0.6DIR	0 = Outputs, 1 = Inputs
5	0 = GPIO_0.5DIR	0 = Outputs, 1 = Inputs
4	0 = GPIO_0.4DIR	0 = Outputs, 1 = Inputs
3	0 = GPIO_0.3DIR	0 = Outputs, 1 = Inputs
2	0 = GPIO_0.2DIR	0 = Outputs, 1 = Inputs
1	0 = GPIO_0.1DIR	0 = Outputs, 1 = Inputs
0	0 = GPIO_0.0DIR	0 = Outputs, 1 = Inputs

2.1.1.2.22 Register 721, CCD Internal I/O Read/Write Register 1

Register 721 is a 8 bit, read/write register that controls CPLD GPIO input on read, and out value on write. The default data is 0b00000000. The table below shows the mapping of these bits.

Table 20: Register 721, CCD Internal I/O Read/Write Register 1

Bit #	Signal	State Action
7	0 = GPIO_0.7	Write bit when DIR = 0 Read bit when DIR = 1
6	0 = GPIO_0.6	Write bit when DIR = 0 Read bit when DIR = 1
5	0 = GPIO_0.5	Write bit when DIR = 0 Read bit when DIR = 1
4	0 = GPIO_0.4	Write bit when DIR = 0 Read bit when DIR = 1
3	0 = GPIO_0.3	Write bit when DIR = 0 Read bit when DIR = 1
2	0 = GPIO_0.2	Write bit when DIR = 0 Read bit when DIR = 1
1	0 = GPIO_0.1	Write bit when DIR = 0 Read bit when DIR = 1
0	0 = GPIO_0.0	Write bit when DIR = 0 Read bit when DIR = 1

2.1.1.2.23 Register 722, CCD Internal I/O Direction Register 2

Register 722 is a 8 bit, read/write register that controls CPLD GPIO to CCD Connector pin input/output mapping. The default data is 0b11111111. The table below shows the mapping of these bits.

Table 21: Register 722, CCD Internal I/O Direction Register 2

Bit #	Signal	State Action
7	0 = GPIO_1.7DIR	0 = Outputs, 1 = Inputs
6	0 = GPIO_1.6DIR	0 = Outputs, 1 = Inputs
5	0 = GPIO_1.5DIR	0 = Outputs, 1 = Inputs
4	0 = GPIO_1.4DIR	0 = Outputs, 1 = Inputs
3	0 = GPIO_1.3DIR	0 = Outputs, 1 = Inputs
2	0 = GPIO_1.2DIR	0 = Outputs, 1 = Inputs
1	0 = GPIO_1.1DIR	0 = Outputs, 1 = Inputs
0	0 = GPIO_1.0DIR	0 = Outputs, 1 = Inputs

2.1.1.2.24 Register 723, CCD Internal I/O Read/Write Register 2

Register 723 is a 8 bit, read/write register that controls CPLD GPIO input on read, and out value on write. The default data is 0b00000000. The table below shows the mapping of these bits.

Table 22: Register 723, CCD Internal I/O Read/Write Register 2

Bit #	Signal	State Action
7	0 = GPIO_0.7	Write bit when DIR = 0 Read bit when DIR = 1
6	0 = GPIO_0.6	Write bit when DIR = 0 Read bit when DIR = 1
5	0 = GPIO_0.5	Write bit when DIR = 0 Read bit when DIR = 1
4	0 = GPIO_0.4	Write bit when DIR = 0 Read bit when DIR = 1
3	0 = GPIO_0.3	Write bit when DIR = 0 Read bit when DIR = 1
2	0 = GPIO_0.2	Write bit when DIR = 0 Read bit when DIR = 1
1	0 = GPIO_0.1	Write bit when DIR = 0 Read bit when DIR = 1
0	0 = GPIO_0.0	Write bit when DIR = 0 Read bit when DIR = 1

2.1.1.2.25 Register 724, CCD Internal I/O Direction Register 3

Register 724 is a 8 bit, read/write register that controls CPLD GPIO to CCD Connector pin input/output mapping. The default data is 0b11111111. The table below shows the mapping of these bits.

Table 23: Register 724, CCD Internal I/O Direction Register 3

Bit #	Signal	State Action
7	0 = GPIO_2.7DIR	0 = Outputs, 1 = Inputs
6	0 = GPIO_2.6DIR	0 = Outputs, 1 = Inputs
5	0 = GPIO_2.5DIR	0 = Outputs, 1 = Inputs
4	0 = GPIO_2.4DIR	0 = Outputs, 1 = Inputs
3	0 = GPIO_2.3DIR	0 = Outputs, 1 = Inputs
2	0 = GPIO_2.2DIR	0 = Outputs, 1 = Inputs
1	0 = GPIO_2.1DIR	0 = Outputs, 1 = Inputs
0	0 = GPIO_2.0DIR	0 = Outputs, 1 = Inputs

2.1.1.2.26 Register 725, CCD Internal I/O Read/Write Register 3

Register 725 is a 8 bit, read/write register that controls CPLD GPIO input on read, and out value on write. The default data is 0b00000000. The table below shows the mapping of these bits.

Table 24: Register 725, CCD Internal I/O Read/Write Register 1

Bit #	Signal	State Action
7	0 = GPIO_0.7	Write bit when DIR = 0 Read bit when DIR = 1
6	0 = GPIO_0.6	Write bit when DIR = 0 Read bit when DIR = 1
5	0 = GPIO_0.5	Write bit when DIR = 0 Read bit when DIR = 1
4	0 = GPIO_0.4	Write bit when DIR = 0 Read bit when DIR = 1
3	0 = GPIO_0.3	Write bit when DIR = 0 Read bit when DIR = 1
2	0 = GPIO_0.2	Write bit when DIR = 0 Read bit when DIR = 1
1	0 = GPIO_0.1	Write bit when DIR = 0 Read bit when DIR = 1
0	0 = GPIO_0.0	Write bit when DIR = 0 Read bit when DIR = 1

2.1.1.3 Key Pad Interface

The DM365 has an internal key pad controller. The key pad interface is multiplexed with the address lines on the asynchronous EMIF. CBTLV multiplexers are used to redirect the key pad interface to the key pad matrix. This interface can only be used when CE0 is in the NAND configuration. A control bit in the CPLD enables the Mux select on the CBTLV multiplexers. The 16 bit switch key pad matrix is set up on a 4 x 4 matrix on the EVM. The mapping of the switches are shown in the table below.

Table 25: Key Pad Layout

	Key-A0	Key-A0	Key-A1	Key-A1
Key-B0	SW6 / KEY 2	SW7 / LEFT	SW8 / EXIT	SW9 / DOWN
Key-B0	SW10 / ENTER	SW11 / UP	SW12 KEY 1	SW13 / RIGHT
Key-B1	SW14 / MENU	SW15 / REC	SW16 / REW	SW17 / SKIP-
Key-B1	SW18 / STOP	SW19 / FF	SW20 / SKIP+	SW2 / PLAY/ PAUSE

2.1.2 DDR2 Memory Interface

The DM365 device incorporates a dedicated 16 bit wide DDR2 memory bus. The EVM uses a single 1 gigabit 16 bit wide memory on this bus, for a total of 128 megabytes of memory for program, data, and video storage. The internal DDR controller uses a PLL to control the DDR memory timing. Memory refresh for DDR2 is handled automatically by the DM365 internal DDR controller.

2.1.3 Media Card Interface

The EVM supports 1 SD/MMC/MS and 1 SD/MMC media card interfaces. The MMC/SD0 port is dedicated to the SD/MMC/MS media card. The insert and write protect status can be read via CPLD register. MMC/SD1 port is configured to a second SD/MMC media card. This port is multiplexed via CBTLV switches to be used as general purpose I/O pins when the CPLD is appropriately configured for I/O multiplexing. The insert and write protect pin status can be read via a CPLD register.

2.1.4 UART Interface

The internal UART0 on the DM365 device is driven to connector P1. The UART's interface is routed to the RS-232 line drivers prior to being brought out to a DB-9 connector, P1.

2.1.5 USB Interface

The DM365 incorporates an on chip USB II controller. This interface is brought out to a mini A/B connector. Two jumpers are provided to make a flexible Host peripheral, and USB On The Go interface. J26 is used to manually select the ID pin state. J6 is used to add additional capacitance to VBUS for host mode operation. A TPS2065 is used to power VBUS via DRV_VBUS signal for Host mode applications. The CPLD selects the source pin for DRV_VBUS signals via internal CPLD registers.

2.2 Input Video Port Interfaces/Imager Input Ports

The DM365 EVM supports composite, component, or imager video capture. CBT multiplexers selected via CPLD registers chose the interface that is connected to the DM365 video input port. A Texas Instruments TVP5146 is used to decode composite video or S-video inputs into the device. J15 is used for the S-video inputs and J13 for the composite inputs on the EVM.

A TVP7002 provides component image capture up to 720P resolution.

J11, J8, J9 interface to a THS7353 amplifier/filter which interfaces directly to the TVP7002 which drives the DM365 input port.

J10, a DIN96 connector allows users to support imager interfaces. This is mapped directly to the video input port via CBT mux. The figure below shows this mapping,

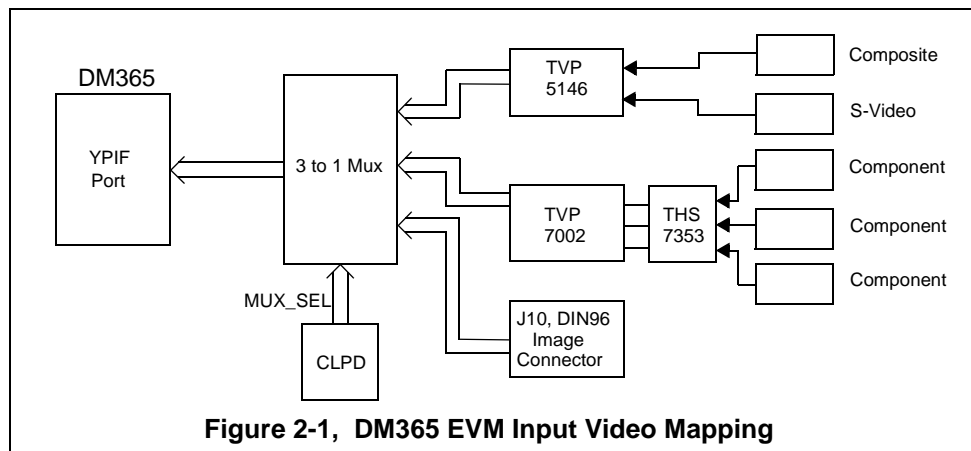

2.2.1 On Chip Video Output DAC

The DM365 incorporates 1 TV composite video output DAC and 3 component video DACs to interface to composite and component video outputs. The TV Out DAC is filtered and driven to RCA jack, J16.

The component output DACs are driven into a THS7303 video amplifier and output to RCA connectors J21, J17, J20.

2.2.2 LCD Video Connectors

The DM365 incorporates 3 interface connectors; J18, J19, and J23 for digital video output for interfacing to LCD displays. The pinouts for these displays are detailed in section 3 of this manual.

2.3 AIC3101 Interface

The EVM uses a Texas Instruments TLV320AIC3101 stereo codec for input and output of audio signals. The codec samples analog signals on the microphone or line inputs and converts them into digital data so it can be processed by the DSP. When the DSP is finished with the data it uses the codec to convert the samples back into analog signals on the line output so the user can hear the output.

The codec communicates using two serial channels, one to control the codec’s internal configuration registers and one to send and receive digital audio samples. The I²C bus is used as the AIC3101’s control channel. The control channel is generally only used when configuring the codec, it is typically idle when audio data is being transmitted,

The DM365’s McBSP is used as the bi-directional data channel. All audio data flows through the data channel. Many data formats are supported based on the three variables of sample width, clock signal source and serial data format. The EVM examples generally use a 16-bit sample width with the codec in master mode so it generates the frame sync and bit clocks at the correct sample rate without effort on the DSP side.

The codec is clocked via a 27 Mhz oscillator. The internal sample rate generator subdivides the default system clock to generate common audio frequencies. The sample rate is set by a codec register. The figure below shows the codec interface on the DM365 EVM.

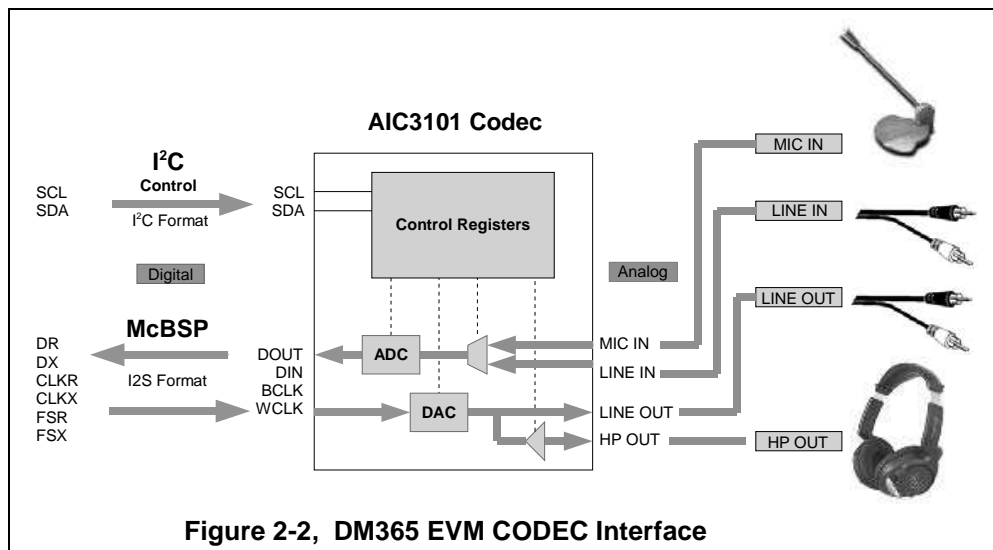

Figure 2-2, DM365 EVM CODEC Interface

2.4 On Chip Voice Codec

The DM365 integrates a single channel voice codec. The input for this codec is connected to on board microphone M1. The output of this codec is connected to on board speaker SPK1.

2.5 On Chip Analog to Digital Converter (ADC)

The DM365 has an on chip 6 channel Analog to Digital Converter (ADC). Four of the channels are interfaced to on board voltages and two channels are connected to test points as shown in the table below.

Table 26: On Chip Analog to Digital Converter

Channel	Input Signal
ADC_CH0	CCD_PSMON
ADC_CH1	VCC_3V3
ADC_CH2	CPU_VCC_1V8
ADC_CH3	VCC_1V2
ADC_CH4	TP37
ADC_CH5	TP36

2.6 On Chip RTC

The DM365 integrates an on chip real time clock. The Real Time Clock is battery backed up via TPS65510 and Battery BHT1. The EVM is not shipped with a backup battery. The mode of operation for the Real Time Clock is configured via switch SW23, as defined in section 3.

2.7 Ethernet Interface

The DM365 incorporates an internal MII ethernet MAC which interfaces to a Mircel 10/100 ethernet Phy. The 10/100 Mbit interface is isolated and brought out to a RJ-45 standard ethernet connector, P2. The ethernet address is stored in the on board I²C EEPROM manufacturing.

For GPIO modes of operation when the MII interface is not used CBTLV multiplexes and directs the I/O to the on board CPLD used as imager expansion I/Os.

The RJ-45 has 2 LEDs integrated into its connector. The LEDs are green and yellow and indicate the status of the ethernet link. The green LED, when on, indicates link and when blinking indicates link activity. The yellow LED, when illuminated, indicates full duplex mode.

2.8 I²C Interface

The I²C bus on the DM365 is ideal for interfacing to the control registers of many devices. On the DM365 EVM the I²C bus is used to configure the video decoders, stereo Codec, video amplifiers, I2C EEPROM, and communicate with the MSP430. An I²C ROM is also interfaced via the serial bus. The format of the bus is shown in the figure below.

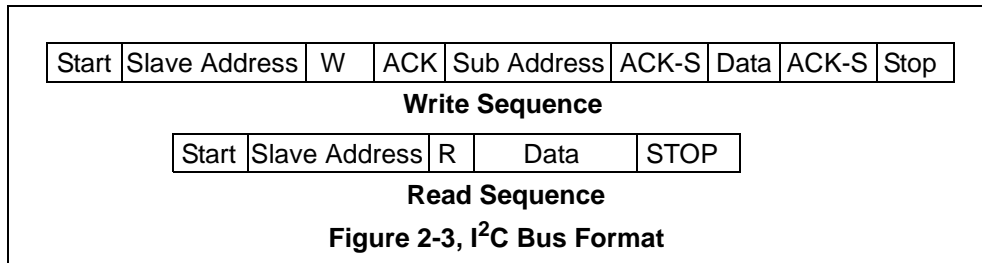

The addresses of the on board peripherals are shown in the table below.

Table 27: I²C Memory Map

Device	Address	R/W	Function
AIC3101	0x18	R/W	CODEC
MSP430	0x25	R/W	IR Controller
THS7303	0x2C	R/W	Video Output Amplifier
THS7353	0x2E	R/W	Video Input Amplifier
CAT24C256	0x50	R/W	I ² C EEROM
TVP7002	0x5C	R/W	Component Decoder
TVP5146	0x5D	R/W	Composite 1 Decoder

2.8.1 MSP430

The DM365 EVM incorporates infrared remote, interface using a MSP430 microcontroller. The I²C interface is used on the DM365 processor to communicate to the MSP430. The MSP430 acts as a slave device on the I²C bus.

2.9 Daughter Card Interfaces

The EVM provides expansion connectors that can be used to accept plug-in daughter cards. The daughter card allows users to build on their EVM platform to extend its capabilities and provide customer and application specific interfaces. The Asynchronous EMIF is brought out to J14. The video digital output port is brought out to the daughter card interface along with I/O and imager interface is brought out to a DIN96 connector as detailed previously.

2.10 DM365 CPU/Video Clocks

The DM365 EVM uses a 24 Megahertz crystal to generate the main input clock. The DM365 has multiple internal PLLs which can multiply the input clock to generate the internal clocks. The PLL's multipliers are set via software on the DM365 device.

The Real Time clock uses a 32,768 hertz crystal.

2.11 Battery

The DM365 EVM incorporates a battery holder to provide backup power to the internal real time clock when the power is not applied to the board. The optional battery should be +3 volt 20 millimeter coin type Lithium single cell.

Some common part numbers for batteries which should operate in the EVM are shown in the table below.

Table 28: Battery Part Numbers

Part Numbers
CR2032
DL2032
BR2032
CR2025
BR2025
CR2016
BR2016
DL2016

These batteries are available from Duracell, Eveready, Panasonic, Ray-O-Vac, Sanyo, Sony, Sieko, Toshiba, Varta, and other battery manufacturers.

Chapter 3

Physical Description

This chapter describes the physical layout of the DM365 EVM and its interfaces.

Topic	Page
3.1 Board Layout	3-3
3.2 Connectors	3-5
3.2.1 J1, USB MiniAB Connector and Jumpers	3-6
3.2.2 J2, 14 Pin External JTAG Connector	3-7
3.2.3 J3, MSP430 JTAG Header	3-8
3.2.4 J4, Spare Jumper Holder	3-8
3.2.5 J5, 20 Pin ARM JTAG Emulation Header	3-9
3.2.6 J6, USB Capacitance Select	3-9
3.2.7 J7, +5 Volts Input	3-10
3.2.8 J12, SD/MMC/MS Card Interface	3-10
3.2.9 J10, Imager Interface	3-11
3.2.10 J14, EMIF/UPI DC Interface	3-12
3.2.11 J8, Y Component Video In, RCA Jack (Green)	3-13
3.2.12 J9, Pb Component Video In, RCA Jack (Blue)	3-13
3.2.13 J11, Pr Component Video In, RCA Jack (Red)	3-14
3.2.14 J15, S-Video In	3-14
3.2.15 J13, CVBS/Y Input, RCA Jack (Yellow)	3-15
3.2.16 J16, Composite TV Out, RCA Jack (Yellow)	3-15
3.2.17 J17, Y Component Video Out, RCA Jack (Green)	3-16
3.2.18 J20, Pb Component Video Out, RCA Jack (Blue)	3-16
3.2.19 J21, Pr Component Video Out, RCA Jack (Red)	3-17
3.2.20 J18, J19, Video Output DC	3-18
3.2.21 J22, CPLD Programming Header	3-19
3.2.22 J23, I/O Interface Header	3-19
3.2.23 J24, DILC Host Connector	3-20
3.2.24 J25, MMC/SD Connector	3-21
3.2.25 P1, RS-232 UART	3-22
3.2.26 P2, Ethernet Interface	3-23
3.2.27 P3, Microphone In	3-24

Topic	Page
3.2.28 P4, Line In	3-24
3.2.29 P5, Line Out	3-25
3.2.30 P6, Headphone Out	3-25
3.2.31 U1, Infrared Interface	3-26
3.2.32 SPK1, Speaker Interface	3-26
3.2.33 BHT1, Battery Interface	3-27
3.2.34 M1, Microphone Interface	3-27
3.3 LEDs	3-28
3.4 Switches	3-29
3.4.1 SW1, EMU0/1 Select Switch	3-30
3.4.2 SW2, PWCTRO0 Pushbutton	3-30
3.4.3 SW3, Non-Supported Pushbutton	3-30
3.4.4 SW4, Boot Mode / Processor Configuration Select	3-31
3.4.5 SW5, Board Configuration Select	3-32
3.4.6 SW6 - SW21, Function Pushbuttons	3-32
3.4.7 SW22, MSP430 IO0 Pushbutton	3-33
3.4.8 SW23, PRTSC Mode Select	3-33
3.5 Jumpers	3-34
3.5.1 JP1, Jumper Block	3-34
3.6 Test Points	3-35

3.1 Board Layout

The DM365 EVM is a 8.0 x 8.7 inch (203 x 221 mm.) ten (10) layer printed circuit board which is powered by an external +5 volt only power supply. Figure 3-1 shows the layout of the top side of the DM365 EVM.

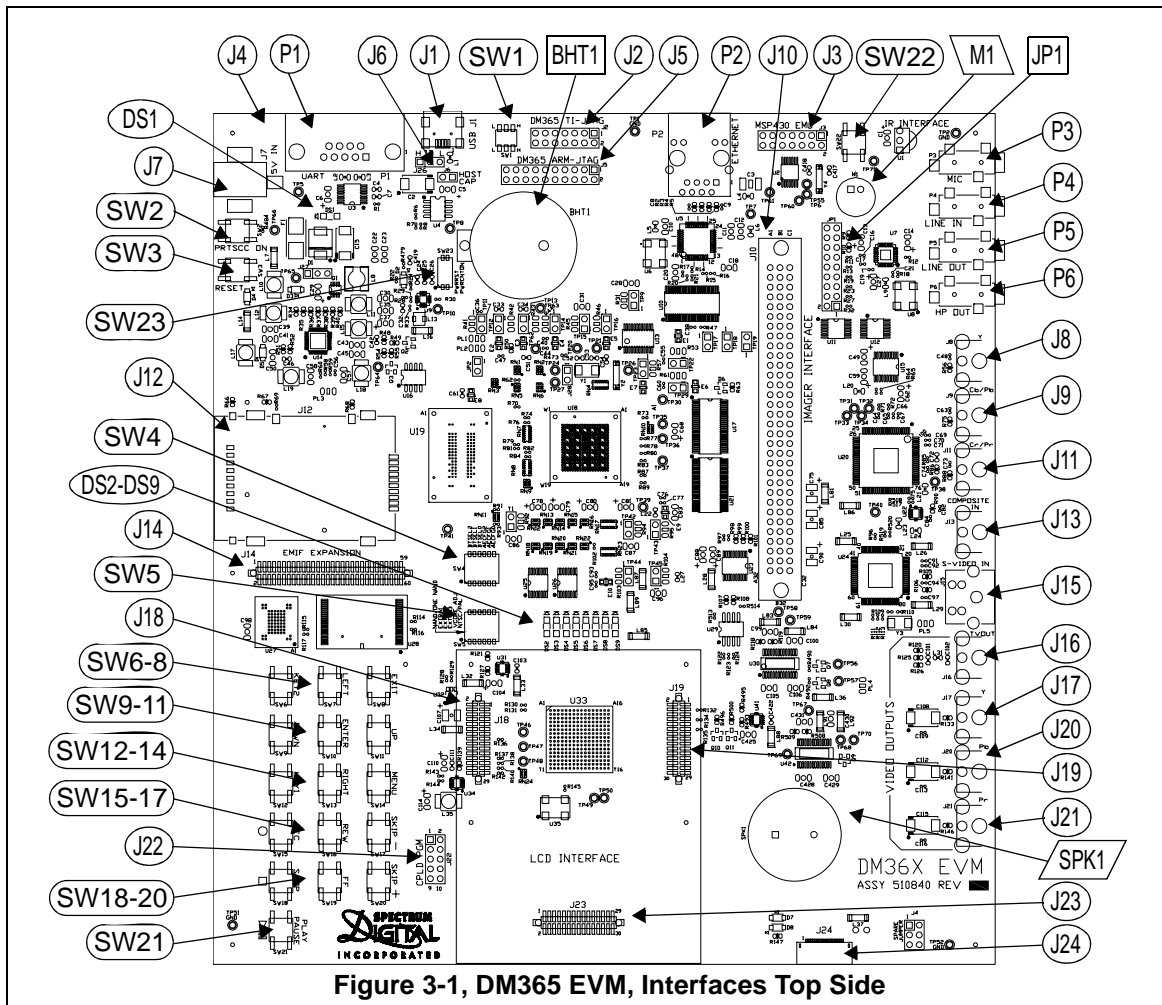
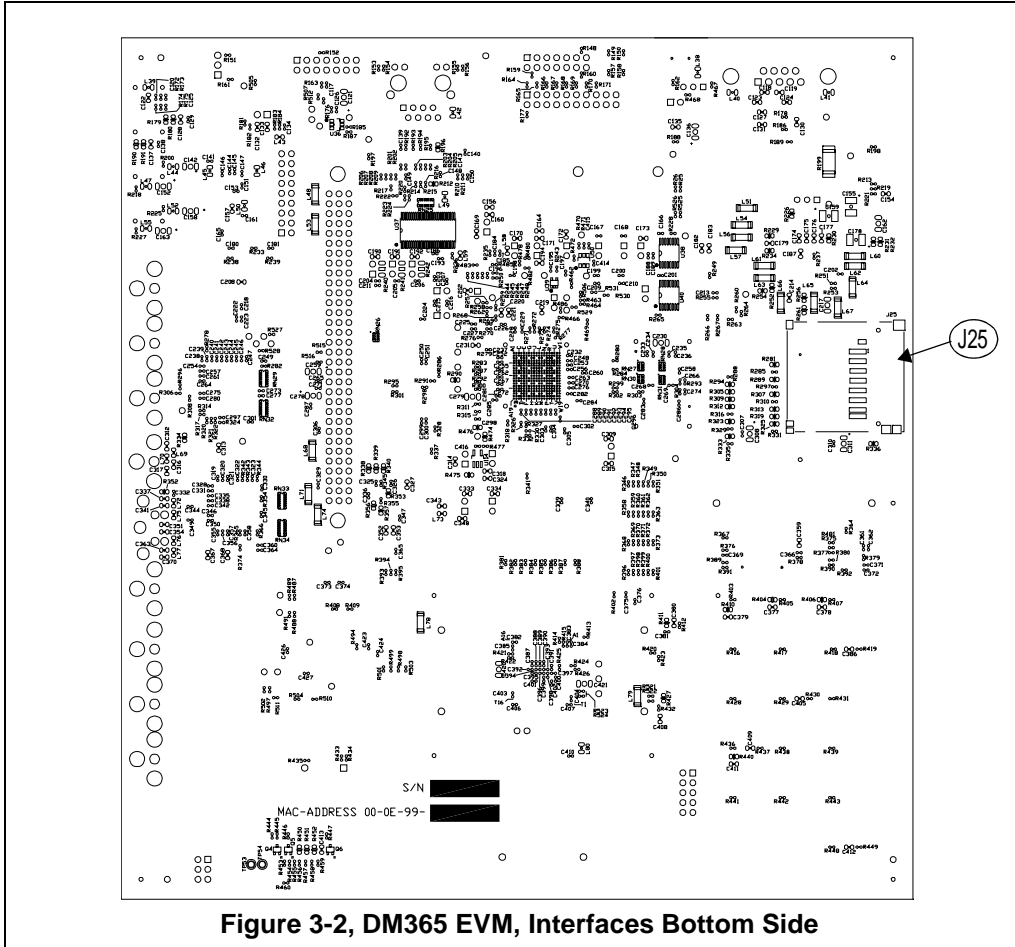

Figure 3-1, DM365 EVM, Interfaces Top Side

Figure 3-2 shows the layout of the bottom side of the DM365 EVM.



3.2 Connectors

The DM365 EVM has numerous connectors, option jumpers, and interfaces to control and provide connections to various peripherals. These connectors and jumpers are described in the following sections.

Table 1: DM365 Connectors

Connector	Size	Function
J1	1 x 4	USB MiniAB Connector
J2	2 x 7	14 Pin TI JTAG Emulation Header
J3	7 x 2	MSP430 JTAG Header
J4	3 x 2	Spare Jumper Holder
J5	10 x 2	20 Pin ARM JTAG Emulation Header
J6	2 x 1	USB Capacitor Select
J7	2	+5 Volts In
J8	2	Y Component Video In, RCA Jack (Grn)
J9	2	Pb Component Video In, RCA Jack (Blue)
J10	32 x 3	Imager Interface
J11	2	Pr Component Video In, RCA Jack (Red)
J12	2	SD/MMC/MS Card Interface
J13	2	CVBS/Y Input, RCA Jack (Yellow)
J14	30 x 2	EMIF/UPHI DC Interface
J15	4	S-video In, DIN connector
J16	2	Composite TV Out, RCA Jack (Yellow)
J17	2	Y Component Video Output, RCA Jack (Green)
J18	15 x 2	Video Output DC
J19	15 x 2	Video Output DC
J20	2	Pb Component Video Output, RCA Jack (Blue)
J21	2	Pr Component Video Output, RCA Jack (Red)
J22	5 x 2	CPLD Programming Header
J23	15 x 2	I/O Interface Header
J24	20 x 1	DILC Host Connector
J25	9	MMC/SD Card Interface
P1	9	RS-232 UART
P2	6	Ethernet Interface
P3	4	Microphone In
P4	4	Line In
P5	4	Line Out
P6	4	Headphone Out
U1	3	Infrared Interface
SPK1	2	Speaker
BHT1	2	Battery Holder
M1	2	Microphone

3.2.1 J1, USB MiniAB Connector and Jumpers

Connector J1 is a mini A/B USB connector. The pinout for the J1 connector is shown in the table below.

Table 2: J1, MiniAB USB Connector

Pins	Signal
1	USB_VBUS_CONN
2	USB_DM
3	USB_DP
4	USB_ID
5	GND

The EVM incorporates the ability to toggle the ID pin on the USB connector via software control. The USB_ID pin on the DM365 controls this function.

For “USB ON The Go” mode remove jumper J6. This will allow the cable to configure the ID pin on the DM365 processor.

The EVM supplies up to 500 ma of current to the USB_VBUS via a TPS61092 DC/DC converter. This is enabled via the DM365’s DRV_VBUS pin. J50 supplies extra capacitance for host mode operations. Remove J50 for “USB On The Go” operations. Spare jumpers can be stored on connector J4.

3.2.2 J2, 14 Pin External JTAG Connector

Connector J2 is a 2 x 7 double row male header with pin 6 clipped to serve as a key. This is the standard interface used by JTAG emulators to interface to Texas Instruments processors. The pinout for the connector is shown in the figure below.

TMS	1	2	TRST-	
TDI	3	4	GND	Header Dimensions
PD (+3.3V)	5	6	no pin (key)	Pin-to-Pin spacing, 0.100 in. (X,Y)
TDO	7	8	GND	Pin width, 0.025-in. square post
TCK-RET	9	10	GND	Pin length, 0.235-in. nominal
TCK	11	12	GND	
EMU0	13	14	EMU1	

Figure 3-3, J2, 14 Pin External JTAG Connector

The signal names for each pin are shown in the table below.

Table 3: J2, 14 Pin External JTAG Connector

Pin #	Signal Name	Pin #	Signal Name
1	TMS	2	TRST-
3	TDI	4	GND
5	PD	6	no pin - key
7	TDO	8	GND
9	TCKRET	10	GND
11	TCK	12	GND
13	EMU0	14	EMU1

* **Note:** EMU0/EMU1 mode must be selected to ICEPICK mode

3.2.3 J3, MSP430 JTAG Header

The J3, MSP430 JTAG header, is located on the top side of the board and is used to provide a programming interface to the MSP430 microcontroller. The pinout for the J3 connector is shown in the table below. This connector is typically used for factory use only.

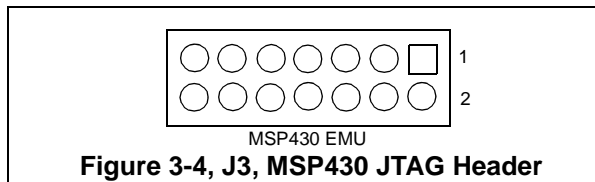

Table 4: J3, MSP430 JTAG Header

Pin #	Signal	Pin #	Signal
1	430_TDO/TDI	2	NC
3	NC	4	MSP430_3V3
5	NC	6	NC
7	TCK	8	NC
9	GND	10	NC
11	NC	12	NC
13	NC	14	NC

3.2.4 J4, Spare Jumper Holder

J4 is a 3 x 2 connector used to hold unused jumper plugs that from time to time may be required in other connectors/jumpers on the D365 EVM. The pins on this connector are not connected to any signals.

3.2.5 J5, 20 Pin ARM JTAG Emulation Header

The J5 emulation header is located on the top side of the board and is used to provide an interface to ARM compatible JTAG emulators. The pinout for this connector is shown in the table below.

Table 5: J5, 20 Pin ARM JTAG Emulation Header

Pin #	Signal	Pin #	Signal
1	VCC_3V3	2	VCC_3V3
3	ARM_TRSTn	4	Ground
5	ARM_TDI	6	Ground
7	ARM_TMS	8	Ground
9	ARM_TCK	10	Ground
11	ARM_TCKRET	12	Ground
13	ARM_TDO	14	Ground
15	ARM_RSTn	16	Ground
17	NC	18	Ground
19	NC	20	Ground

* **Note:** EMU0/EMU1 switch must be set to ARM mode

3.2.6 J6, USB Capacitance Select

The J6 jumper is used to provide more capacitance when the USB connector is used in the host mode. When the jumper is shorted the extra capacitance is provided. These open and shorted position are shown below.

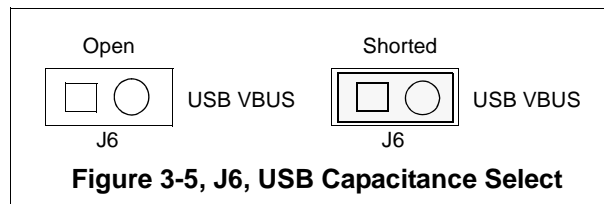
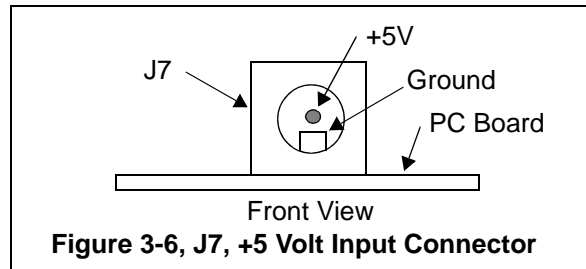

Table 6: J6, USB Capacitance Select

Position	Function
Open	6.8 uF Capacitance
Shorted	106.8 uF Capacitance

3.2.7 J7, +5 Volts Input

Connector J7 is the input power connector. This connector brings in +5 volts to the EVM. This is a 2.5mm. jack. The inside of the jack is tied to through a fuse to VCC_5V. The other side is tied to ground and LED DS1. The figure below shows this connector as viewed from the card edge.



3.2.8 J12, SD/MMC/MS Card Interface

The J12 SD/MMC/MS Card Interface connector is located on the top side of the board and is used to provide an interface to a SD/MMC/MS card. The pinout for the J12 connector is shown in the table below.

Table 7: J12, SD/MMC/MS Connector

Pin #	Signal	Pin #	Signal
1	SD.DATA3	2	SD.CMD
3	SD.VSS1	4	VCC_3V3
5	SD.CLK	6	SD.VSS2
7	SD.DATA0	8	SD.DATA1
9	SD.DATA2	10	GND
11	MS.BS	12	MS.DATA1
13	MS.SDIO/DATA0	14	MS.DATA2
15	MS.XINS	16	MS.DATA3
17	MS.CLK	18	VCC_3V3
19	GND	20	WP
21	INS	22	GND
23	GND		

3.2.9 J10, Imager Interface

Connector J10 is 32 x 3 connector used to interface to external imager logic. The pin out for this connector is shown in the table below.

Table 8: J10, Imager Interface

Pin	Signal	Pin	Signal	Pin	Signal
A1	Ground	B1	GPIO_MD10	C1	GND_STB
A2	Ground	B2	GPIO_MD9	C2	GND_STB
A2	CCD_PSMON	B2	GPIO_MD8	C2	3V3_STB
A4	GPIO_MD1	B4	GPIO_MD7	C4	5V_DC_J6
A5	5V_DC_J6	B5	5V_DC_J6	C5	5V_DC_J6
A6	GND_MTR	B6	MOT_PWR	C6	GPIO_MD19
A7	GND_MTR	B7	MOT_PWR	C7	GPIO_MD18
A8	NC	B8	CCD_DATA0	C8	GPIO_MST_SLV
A9	CDD_DATA2	B9	CCD_DATA15	C9	GPIO_MD17
A10	Ground	B10	CCD_DATA1	C10	GPIO_MD16
A11	CDD_DATA3	B11	GPIO_MD6	C11	GPIO_MD15
A12	Ground	B12	GPIO_MD5	C12	GPIO_MD14
A13	CDD_DATA4	B13	GPIO_MD4	C13	GPIO_MD13
A14	Ground	B14	Ground	C14	GPIO_TACH
A15	CDD_DATA5	B15	PWM_CCD_SUB	C15	GPIO_MD12
A16	Ground	B16	CCD_DDSRST	C16	GPIO_MD11
A17	CDD_DATA6	B17	GPIO_MD3	C17	I2C_DATA
A18	Ground	B18	GPIO_MD2	C18	I2C_SCLK
A19	CDD_DATA7	B19	SPI4_SDO	C19	VCC_CCD15V
A20	Ground	B20	SPI4_SCLK	C20	VCC_CCD15V
A21	CDD_DATA8	B21	Ground	C21	VCC_CCD_N75V
A22	Ground	B22	CDD_PCLK	C22	VCC_CCD_N75V
A23	CDD_DATA9	B23	Ground	C23	3V3_CCD
A24	Ground	B24	CDD_WEN	C24	3V3_CCD
A25	CDD_DATA10	B25	Ground	C25	5V_DC_J6
A26	Ground	B26	CDD_FIELD	C26	5V_DC_J6
A27	CDD_DATA11	B27	Ground	C27	Ground
A28	Ground	B28	CDD_HSYNC	C28	Ground
A29	CDD_DATA12	B29	Ground	C29	3V3A_CCD
A30	Ground	B30	CDD_VSYNC	C30	3V3A_CCD
A31	CDD_DATA13	B31	Ground	C31	AGND_IMAGER
A32	Ground	B32	CDD_DATA14	C32	AGND_IMAGER

3.2.10 J14, EMIF/UPI DC Interface

Table 9: J14, EMIF/UPI DC Interface

Pin	Signal	Pin	Signal
2	Ground	1	Ground
4	EM_D0	3	EM_D1
6	EM_D2	5	EM_D3
8	EM_D4	7	EM_D5
10	EM_D6	9	EM_D7
12	Ground	11	Ground
14	EM_D8	13	EM_D9
16	EM_D10	15	EM_D11
18	EM_D12	17	EM_D13
20	EM_D14	19	EM_D15
22	Ground	21	Ground
24	EM_WAIT	23	EM_CLK
26	Ground	25	Ground
28	EM_CE0	27	EM_ADV
30	Ground	29	Ground
32	EM_CE1	31	EM_WE
34	Ground	33	Ground
36	EMIF_SEL	35	EM_OE
38	Ground	37	Ground
40	EM_BA0	39	EM_BA1
42	EM_A0	41	EM_A1
44	EM_A2	43	EM_A3
46	EM_A4	45	EM_A5
48	Ground	47	Ground
50	EM_A6	49	EM_A7
52	EM_A8	51	EM_A9
54	EM_A10	53	EM_A11
56	EM_A12	55	EM_A13
58	VCC_3V3	57	VCC_3V3
60	VCC_5V	59	VCC_5V

3.2.11 J8, Y Component Video In, RCA Jack (Green)

J8 is an RCA jack used as a Y component input to the THS7353, U15, pin 3. The figure below shows this connector as viewed from the card edge.

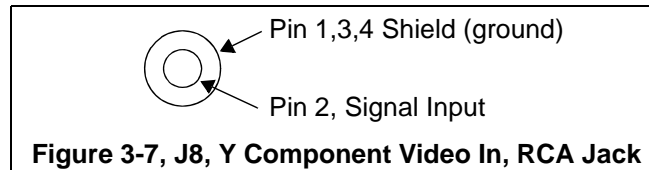

Table 10: J8, Y Component Video In, RCA Jack

Pin #	Signal Name
1	TVP_AGND
2	CH2-INA, U15, Pin 3
3	TVP_AGND
4	TVP_AGND

3.2.12 J9, Pb Component Video In, RCA Jack (Blue)

J9 is an RCA jack used as a Pb component input to the THS7353, U15, pin 4. The figure below shows this connector as viewed from the card edge.

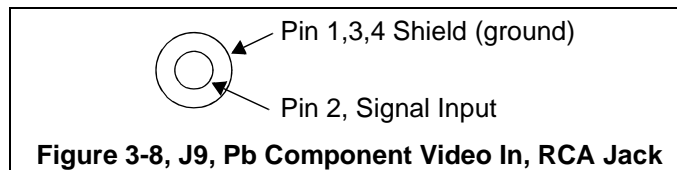

Table 11: J9, Pb Component Video In, RCA Jack

Pin #	Signal Name
1	TVP_AGND
2	CH3-INA, U15, Pin 4
3	TVP_AGND
4	TVP_AGND

3.2.13 J11, Pr Component Video In, RCA Jack (Red)

J11 is an RCA jack used as a Pr component input to the THS7353, U15, pin 2. The figure below shows this connector as viewed from the card edge.

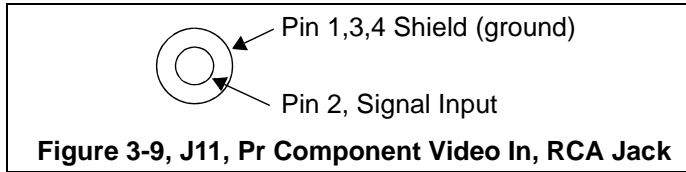

Table 12: J11, Pr Component Video In, RCA Jack

Pin #	Signal Name
1	TVP_AGND
2	CH1-INA, U15, Pin 2
3	TVP_AGND
4	TVP_AGND

3.2.14 J15, S-Video In

Connector J15 is a four pin mini din connector which interfaces to the TVP5146 encoder, U24. This connector brings in a video signal (LUMA) to pin 9 on the TVP5146. Do **NOT** plug into this connector with the power on. The figure below shows this connector as viewed from the card edge.

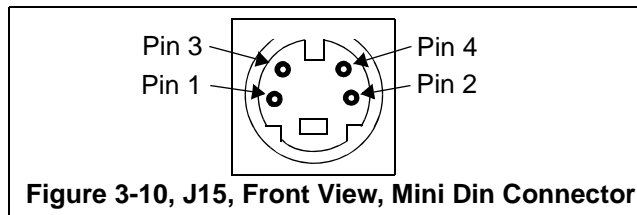

Table 13: J15, S-Video In, Mini Din Connector

Pin #	Signal Name
1	GND
2	GND
3	VI_1_C, U24, Pin 2
4	Chroma

3.2.15 J13, CVBS/Y Input, RCA Jack (Yellow)

J13 is an RCA jack used as the CVBS/Y input to the TVP5146. The figure below shows this connector as viewed from the card edge.

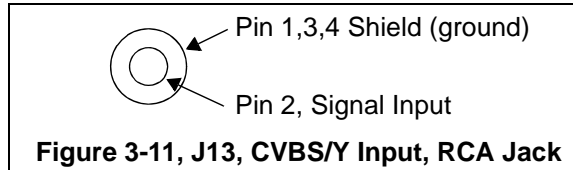

Table 14: J13, CVBS/Y Input, RCA Jack

Pin #	Signal Name
1	DEC_GND
2	VI_2_B, U24, Pin 8, TVP5146
3	DEC_GND
2	DEC_GND

3.2.16 J16, Composite TV Out, RCA Jack (Yellow)

J16 is an RCA jack used as a TV output from the DM365. This connector brings out a TV signal. The figure below shows this connector as viewed from the card edge.

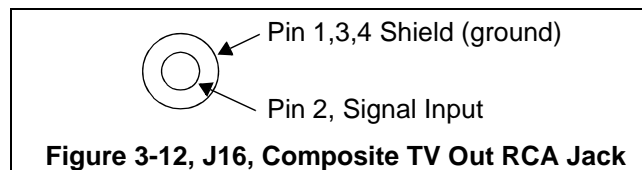

Table 15: J16, Composite TV Out, RCA Jack

Pin #	Signal Name
1	DEC_GND
2	U18-3, Pin A10
3	DEC_GND
2	DEC_GND

3.2.17 J17, Y Component Video Out, RCA Jack (Green)

J17 is an RCA jack used as a green component output from the THS7303 DAC, U23, pin 17, signal CH2-OUT. The figure below shows this connector as viewed from the card edge.

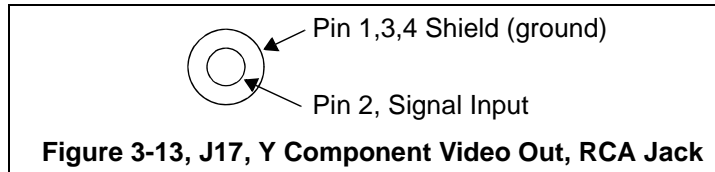

Figure 3-13, J17, Y Component Video Out, RCA Jack

Table 16: J17, Y Component Video Out, RCA Jack

Pin #	Signal Name
1	DENC_GND
2	THS7303 DAC, U23, pin 19,signal CH2-OUT
3	DENC_GND
4	DENC_GND

3.2.18 J20, Pb Component Video Out, RCA Jack (Blue)

J20 is an RCA jack used as a Pb component output from the THS7303 DAC, U23, pin 15, signal CH3-OUT. The figure below shows this connector as viewed from the card edge.

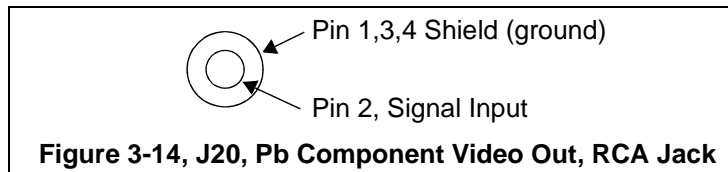

Figure 3-14, J20, Pb Component Video Out, RCA Jack

Table 17: J20, Pb Component Video Out, RCA Jack

Pin #	Signal Name
1	DENC_GND
2	THS7303 DAC, U23, pin 15,signal CH3-OUT
3	DENC_GND
2	DENC_GND

3.2.19 J21, Pr Component Video Output, RCA Jack (Red)

J21 is an RCA jack used as a Pr component output from the THS7303 DAC, U23, pin 19, signal CH1-OUT. The figure below shows this connector as viewed from the card edge.

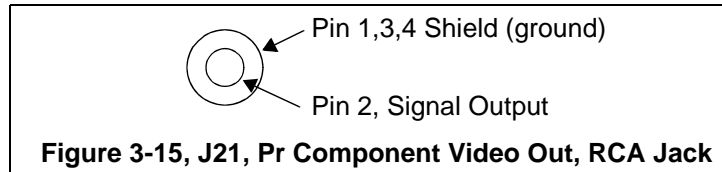

Table 18: J21, Pr Component Video Out, RCA Jack

Pin #	Signal Name
1	DENC_GND
2	THS7303 DAC, U23, pin 19, signal CH1-OUT
3	DENC_GND
4	DENC_GND

3.2.20 J18, J19, Video Output DC

Connectors J18 and J19 make up the interface to the video output DC interface. The signals on each of these connectors are shown in the tables below.

Table 19: J18, Video Output DC

Pin	Signal	Pin	Signal
1	BL_6V6	2	LCD_3V3
3	BL_6V6_RTN	4	LCD_3V3
5	Ground	6	Ground
7	VDOUT_VSYNC	8	NC
9	Ground	10	LCD_V5
11	VDOUT_HSYNC	12	LCD_V5
13	Ground	14	Ground
15	VDOUT_VCLK	16	CDOUT_FIELD
17	Ground	18	15V_LCD
19	BAT_VIN	20	15V_LCD
21	BAT_VIN	22	Ground
23	SPI1_SDI	24	VDOUT_EXTCLK
25	SPI1_SDENA0	26	I2C_DATA
27	SPI1_SDO	28	I2C_SCLK
29	SPI_SCLK	30	Ground

Table 20: J19, Video Output DC

Pin	Signal	Pin	Signal
1	VDOUT_Y0	2	VDOUT_C0
3	R1_GIO33	4	Ground
5	VDOUT_Y1	6	VDOUT_C1
7	R1_GIO32	8	Ground
9	VDOUT_Y2	10	VDOUT_C2
11	R1_GIO30	12	Ground
13	VDOUT_Y3	14	VDOUT_C3
15	Ground	16	Ground
17	VDOUT_Y4	18	VDOUT_C4
19	Ground	20	Ground
21	VDOUT_Y5	22	VDOUT_C5
23	Ground	24	Ground
25	VDOUT_Y6	26	VDOUT_C6
27	Ground	28	Ground
29	VDOUT_Y7	30	VDOUT_C7

3.2.21 J22, CPLD Programming Header

The J22, CPLD programming header, is for use by the factory. This header is not intended to be used outside the factory. The signals on this header are shown in the table below.

Table 21: J22, CPLD Programming Header

Pins	Signal	Pins	Signal
1	ISR_TCK	2	Ground
3	ISR_TDO	4	VCC_3V3
5	ISR_TMS	6	NC
7	NC	8	NC
9	ISR_TDI	10	Ground

3.2.22 J23, I/O Interface Header

Connector J23 is an I/O interface header allowing the user to connect external logic to interface with the I/O pins on the CPLD U33. The signals on this header are shown in the table below.

Table 22: J23, I/O Interface Header

Pins	Signal	Pins	Signal
2	VCC_1V8	1	VCC_1V8
4	NC	3	NC
6	CPLD.COMM_GIO6	5	CPLD.COMM_GIO7
8	CPLD.COMM_GIO16	7	CPLD.COMM_GIO17
10	CPLD.COMM_GIO54	9	CPLD.COMM_GIO67
12	CPLD.COMM_GIO65	11	CPLD.COMM_GIO31
14	CPLD.COMM_GIO63	13	CPLD.COMM_GIO64
16	CPLD.COMM_GIO62	15	CPLD.COMM_GIO61
18	CPLD.COMM_GIO60	17	CPLD.COMM_GIO59
20	CPLD.COMM_GIO58	19	CPLD.COMM_GIO57
22	CPLD.COMM_GIO56	21	CPLD.COMM_GIO32
24	NC	23	NC
26	NC	25	NC
28	CPLD.CONN_RESETn	27	NC
30	Ground	29	Ground

3.2.23 J24, DILC Host Connector

J24 is the DILC Host Connector. The signals on this connector are shown in the table below.

Table 23: J24, DILC Host Connector

Pins	Signal
1	CAM_PWR
2	CAM_PWR
3	SPI2_SCLK_DILC
4	Ground
5	SPI2_SDO_DILC
6	Ground
7	SPI2_SDI_DILC
8	Ground
9	LINEOUT
10	AVJ_DET
11	TP53
12	TP33
13	GIO_DILC_CHG_CTL
14	CD1
15	CD2
16	VBUS1
17	TP54
18	Ground
19	TVOUT
20	Ground
MP1	Ground
MP2	Ground

3.2.24 J25, MMC/SD Connector

The J25 MMC/SD connector is located on the bottom side of the board and is used to provide an interface to a MMC/SD card. The pinout for the J25 connector is shown in the table below.

Table 24: J25, MMC/SD Connector

Pin #	Signal	Pin #	Signal
1	CONN_SD1_DATA3	2	CONN_SD1_CMD
3	GND	4	VCC_3V3
5	CONN_SD1_CLK	6	GND
7	CONN_SD1_DATA0	8	CONN_SD1_DATA1
9	CONN_SD1_DATA2	10	WP, VCC_3V3
11	GND	12	CARD_DETECT

3.2.25 P1, RS-232 UART

The P1 connector is a 9 pin male D-connector which provides a UART interface to the EVM. This connector interfaces to the MAX 3221 RS-232 line driver (U3) and is located on the top side of the board. A view of the connector from the card edge is shown in the figure below. The signals present on this connector are defined in the following table.

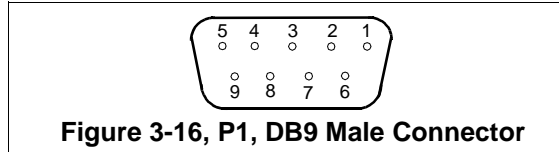

The pin numbers and their corresponding signals are shown in the table below. This corresponds to a standard dual row to DB-9 connector interface used on personal computers.

Table 25: P1, RS-232 UART Pinout

Pin #	Signal Name
1	NC
2	R_IN, U3, Pin 8
3	T_OUT, U3, pin 13
4	NC
5	GND
6	NC
7	Pin 8
8	Pin 7
9	NC

3.2.26 P2, Ethernet Interface

The P2 connector is located on the top side of the board and is used to provide an Ethernet interface. P2 integrates the magnetics and standard RJ-45 connector. The two tables below show the signals present on the magnetics interface and the connector side.

Table 26: P2, Magnetics/LEDs Interface Signals

Pin #	Signal	Pin #	Signal
1	TX+, U5, Pin 41	2	TX-, U5, Pin 40
3	RX+, U5, Pin 33	4	VDD_3V3A
5	VDD_3V3A	6	RX-, U5, Pin 32
7	NC	8	GND_E_NET
9	VCC_3V3A	10	EPHY_LED2
11	VCC_3V3A	12	EPHY_LED0

The ethernet connector incorporates 2 LEDs which give link and transmit status from the ethernet controller.

Table 27: P2, RJ-45 Connector

Pin #	Signal	Pin #	Signal
1	TXD+	2	TXD-
3	RXD+	4	TXD-CT
5	RXD-CT	6	RXD-
7	NC	8	GND
9	LED1+	10	LED1-
11	LED2+	12	LED2-

3.2.27 P3, Microphone In

The microphone input, P3, is a 3.5 mm. stereo jack. Both inputs are connected to the microphone so it is monaural. The signal is connected to signals “MIC2R” and “MIC2L” of the TVL320AIC3101. The signals on the plug are shown in the figure below.

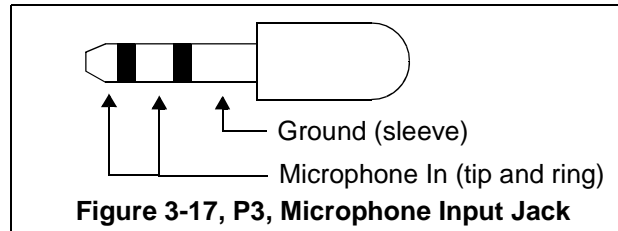

Figure 3-17, P3, Microphone Input Jack

Table 28: P3, Microphone Input Jack

Pin #	Signal Name
1	GND_AIC
2	MIC2L, MIC2R, U7, Pins 14,16
3	MIC2L, MIC2R, U7, Pins 14,16
4	GND_AIC

3.2.28 P4, Line In

Connector P4 is an audio stereo line input to the TVL320AIC3101, U7, on the EVM. The input connector is a 3.5 mm stereo jack. The signals on the mating plug are shown in the figure below.

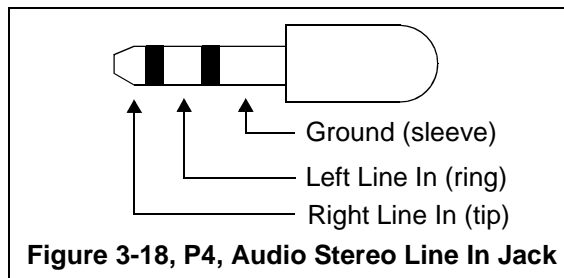

Figure 3-18, P4, Audio Stereo Line In Jack

Table 29: P4, Audio Stereo Line In

Pin #	AIC3101 Signal
1	GND_AIC
2	LINE1LP, U7, Pin 10
3	LINE1RP, U7, Pin 12
4	GND_AIC

3.2.29 P5, Line Out

The connector P5, is an audio stereo output from the TVL320AIC3101, U7, on the EVM. The output connector is a 3.5 mm stereo jack. The signals on the mating plug are shown in the figure below.

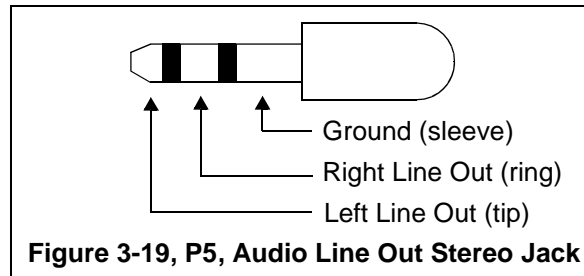

Table 30: P5, Audio Line Out Stereo Jack

Pin #	AIC3101 Signal
1	GND_AIC
2	LEFT_LO+, U7, Pin 27
3	RIGHT_LO+, U7, Pin 29
4	NC

3.2.30 P6, Headphone Out

The P6 connector is a 3.5 mm. stereo headphone output from the TVL320AIC3101, U7, on the EVM. This connector is located on the top side of the board. A view of the connector from the card edge is shown in the figure below. The signals present on this connector are defined in the following table.

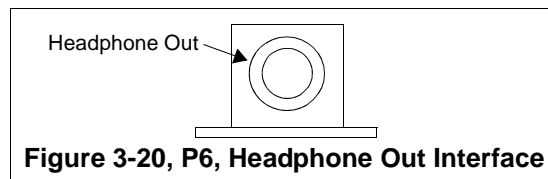
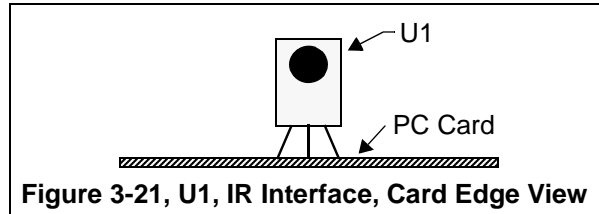

Table 31: P6, Headphone Out Interface

Pin #	AIC3101 Signal
1	GND_AIC
2	HPLOUT, U7, Pin 19
3	HPROUT, U7, Pin 23
4	NC

3.2.31 U1, Infrared Interface

U1 is an infrared receiver mounted on the edge of the board. This device interfaces to the MSP430 microcontroller. The view of U1 is shown from a board edge view in the figure below.



The receiver supports interaction with an Infrared remote control included with your EVM.

Table 32: U1, Infrared Interface

U1 Pin #	MSP430 Signal, Pin #
1	P1.2/TA1/A1+/A4-, U2, Pin 4
2	GND
3	VCC_3V3

3.2.32 SPK1, Speaker Interface

The speaker interface SPK1 provides a speaker output driven directly from the DM365 processor. The connections going to the processor are shown in the table below.

Table 33: SPK1, Speaker Interface

SPK1 Pin #	DM365 Name, Pin #
1	SPP, U18, Pin B9
2	SPN, U18, Pin A9

3.2.33 BHT1, Battery Interface

BHT1 is a holder for a BA2032SM battery. The signals on each pin are shown below in the table below.

Table 34: BHT1, Battery Interface

BHT1 Pin #	BHT1 Connection
1	VBK, Up, Pin 13
2	Ground

3.2.34 M1, Microphone Interface

The microphone interface, M1, provides a microphone input directly into the DM365 processor. The connections going to the processor are shown in the table below.

Table 35: M1, Microphone Interface

M1 Pin #	DM365 Signal Name, Pin #
1	MICIP, U18-9, Pin B8
2	MICIN, U18-9, Pin C9

3.3 LEDs

The EVM has nine (9) LEDs which are located on the top side of the board. Information regarding the LEDs are shown in the table below.

Table 36: LEDs

LED #	Use	Color
DS1	+5 Volts present	Green
DS2	User control via MSP430 I ² C	Green
DS3	User control via MSP430 I ² C	Green
DS4	User control via MSP430 I ² C	Green
DS5	User control via MSP430 I ² C	Green
DS6	User control via MSP430 I ² C	Green
DS7	User control via MSP430 I ² C	Green
DS8	User control via MSP430 I ² C	Green
DS9	User control via MSP430 I ² C	Green

3.4 Switches

The EVM has twenty-three (23) switches. The function of these switches are shown in the table below.

Table 37: Switches

Switch	Function	Type	Silkscreen
SW1	EMU0/EMU1 Control	2 Position DIP	
SW2	PRTSC ON	Push Button/Momentary	PRTSCC
SW3	Non-Supported	Push Button/Momentary	
SW4	Boot/Config Select	6 Position DIP	
SW5	Board Select	6 Position DIP	
SW6	User Readable	Push Button/Momentary	KEY2
SW7	User Readable	Push Button/Momentary	LEFT
SW8	User Readable	Push Button/Momentary	EXIT
SW9	User Readable	Push Button/Momentary	DOWN
SW10	User Readable	Push Button/Momentary	ENTER
SW11	User Readable	Push Button/Momentary	UP
SW12	User Readable	Push Button/Momentary	KEY1
SW13	User Readable	Push Button/Momentary	RIGHT
SW14	User Readable	Push Button/Momentary	MENU
SW15	User Readable	Push Button/Momentary	REC
SW16	User Readable	Push Button/Momentary	REW
SW17	User Readable	Push Button/Momentary	SKIP -
SW18	User Readable	Push Button/Momentary	STOP
SW19	User Readable	Push Button/Momentary	FF
SW20	User Readable	Push Button/Momentary	SKIP +
SW21	Short to Ground	Push Button/Momentary	PLAY PAUSE
SW22	Short to Ground	Push Button/Momentary	
SW23	PRTSC Mode	2 Position DIP	

3.4.1 SW1, EMU0/1 Select Switch

SW1 is a 2 position DIP switch providing 4 options in selecting the state of the EMU0 and EMU1 pins on the TMS320DM365 processor. A view of the switch is shown in the figure below. The selection options with this switch are in the table below.

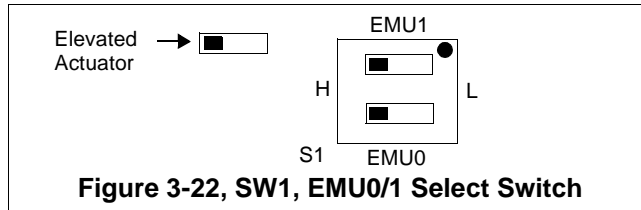

Table 38: SW1, EMU0/1 Select

State at Reset		Function
EMU1	EMU0	
L(0)	L(0)	Reserved
L(0)	H(1)	Reserved
H(1)	L(0)	Reserved
H(1)	H(1)	ICE PICK Mode * Both ARM & DSP JTAG Enabled

* is the factory shipped configuration

3.4.2 SW2, PWCTRO0 Pushbutton

Switch SW2 is a push button momentary switch that forces the PWCTRO0 signal on the DM365, U18-11, pin J3, to ground when the switch is depressed.

3.4.3 SW3, Non-Supported Pushbutton

Switch SW3 is a not currently used for any function

3.4.4 SW4, Boot Mode / Configuration Select

Switch SW4 is a 6 position DIP switch used to select the ARM Boot Mode and processor configuration. The first 3 positions selection the ARM boot mode. The last 3 positions select the processor configuration. The figure and tables below show these options.

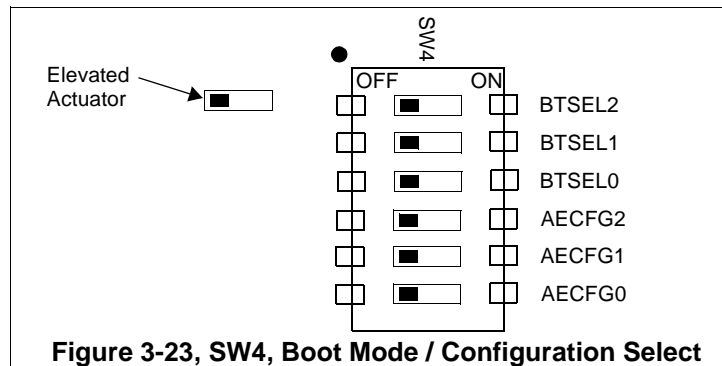

Table 39: SW4, Boot Mode Select

Pos 3	Pos 2	Pos 1	HW Code	Boot Mode
ON	ON	ON	0 0 0	NAND Boot *
ON	ON	OFF	0 0 1	ASYNC EMIF
ON	OFF	ON	0 1 0	MMC/SD Boot
ON	OFF	OFF	0 1 1	UART Boot
OFF	ON	ON	1 0 0	USB Boot
OFF	ON	OFF	1 0 1	SPI Boot
OFF	OFF	ON	1 1 0	EMAC Boot
OFF	OFF	OFF	1 1 1	HPI Boot

Table 40: SW4, Configuration Select

Pos 6	Pos 5	Pos 4	HW Code	Configuration Mode
ON	ON	ON	0 0 0	8-bit AEMIF Configuration *
ON	ON	OFF	0 0 1	16-bit AEMIF Configuration

* default setting

3.4.5 SW5, Board Configuration Select

Switch SW5 is a 6 position switch that configures specific board functions. The figure below shows the switch as it appears on the EVM.

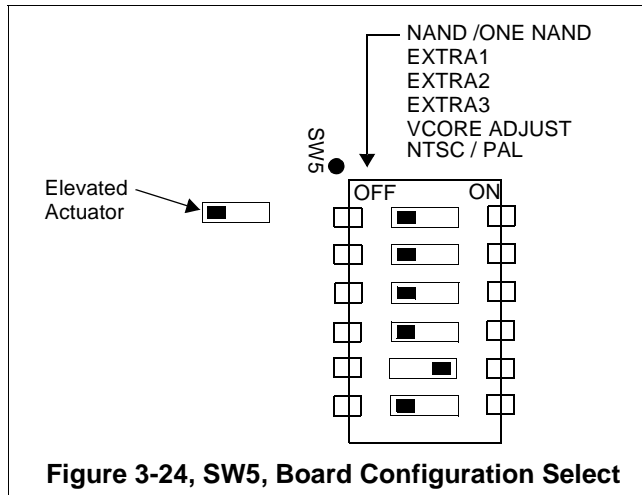

The table below shows the function of each switch position on SW5.

Table 41: SW5, Board Configuration Select

Position	State	Bit Value	Function
1	OFF	0	SELNAND *
	ON	1	SENONENAND
2	OFF	0	Reserved *
	ON	1	Reserved
3	OFF	0	Reserved *
	ON	1	Reserved
4	OFF	0	Reserved *
	ON	1	Reserved
5	OFF	0	Vcore = 1.2 Volts
	ON	1	Vcore = 1.35 Volts *
6	OFF	0	NTSC (CPLD register bit) *
	ON	1	PAL (CPLD register bit)

* = default

3.4.6 SW6 - SW21, Function Pushbuttons

Switches SW6 through SW21 are push button momentary switches that are inputs in to the DM365 processor. These switches can be read with software and their function is determined by the application.

3.4.7 SW22, MSP430 IO0 Pushbutton

Switch SW22 is a push button momentary switch reserved for future use.

3.4.8 SW23, PRTSC Mode Select

Switch SW23 is a 2 position DIP switch that allows the user to select _____. Only **one** switch should be engaged at a time. The figure below shows the switch as it appears on the EVM.

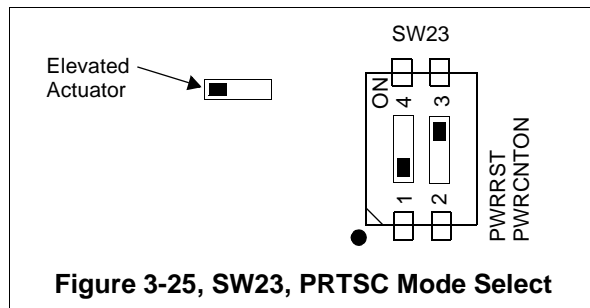

The table below shows the setting for SW23.

Table 42: SW23, PRTSC Mode Select

Position #	Signal Name	Function
1 - 4	XRESET pulled high on TPS65510	_____
2 - 3	CS pulled high on TPS65510	_____ *

* default

3.5 Jumpers

The following section describes the jumpers on the DM365 EVM.

3.5.1 JP1, Jumper Block

Jumper block JP1 allows the user to connect signals from the DM365 processor to the TVL320AIC3101, U7. The signals on this 9 x 2 header are shown in the table below.

Table 43: JP1, Jumper Block

Pin #	Signal Name	Pin #	Signal Name
2	AIC_McBSP_CLKX	1	AIC_BCLK, U7, Pin 2
4	AIC_McBSP_CLKR	3	AIC_BCLK, U7, Pin 2
6	AIC_McBSP_FSX	5	AIC_WCLK
8	AIC_McBSP_FSR	7	AIC_WCLK
10	AIC_McBSP_DX	9	AIC_DIN
12	AIC_McBSP_DR	11	AIC_DOUT
14	I2C_DATA	13	SDA, U7, Pin 9
16	I2C_SCLK	15	SDL, U7, Pin 8
18	Ground	17	Ground

3.6 Test Points

The EVM has 55 test points. The following 2 figures identify the position of each test point. The next two tables lists each test point and the signal appearing on that test point.

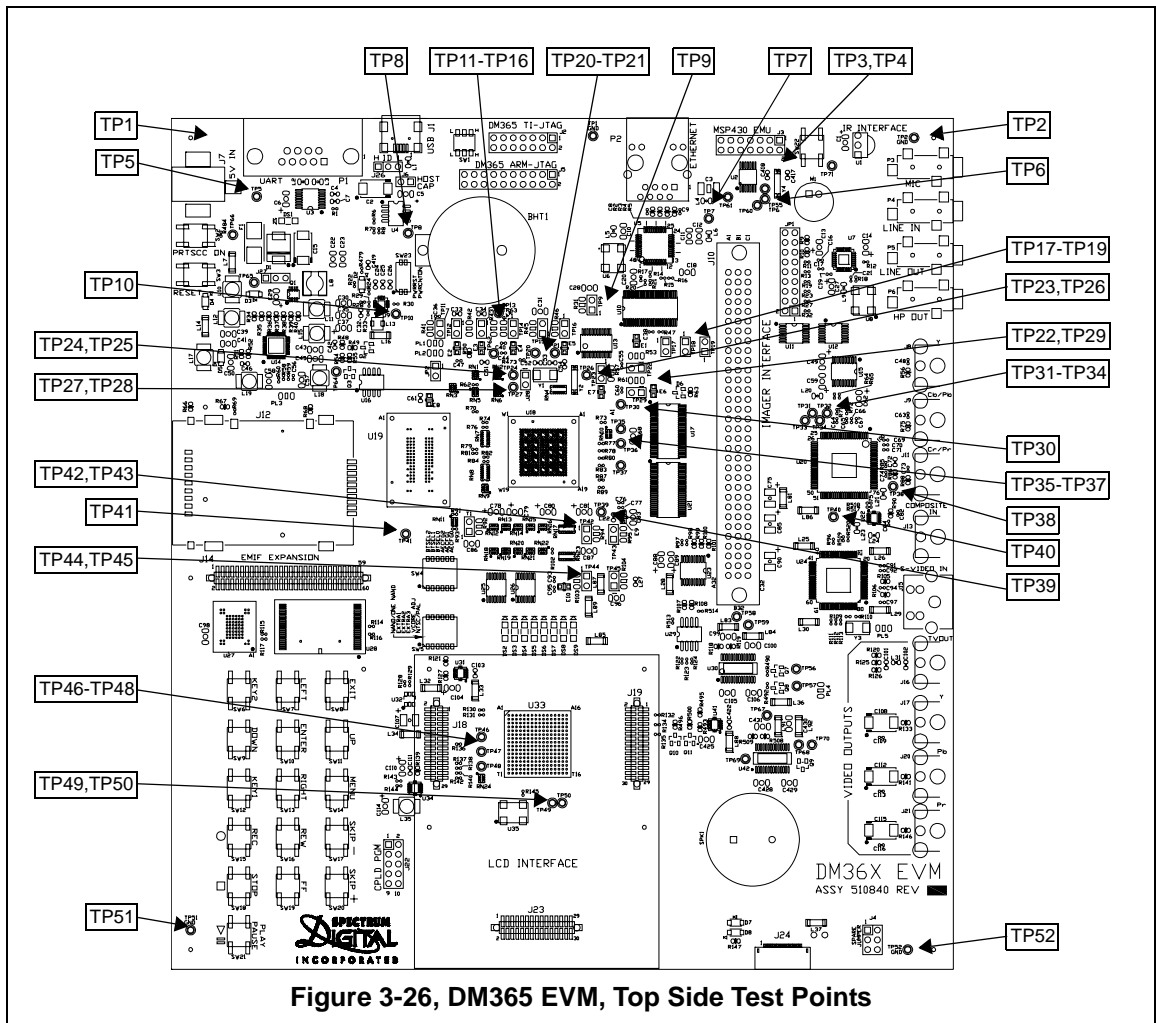

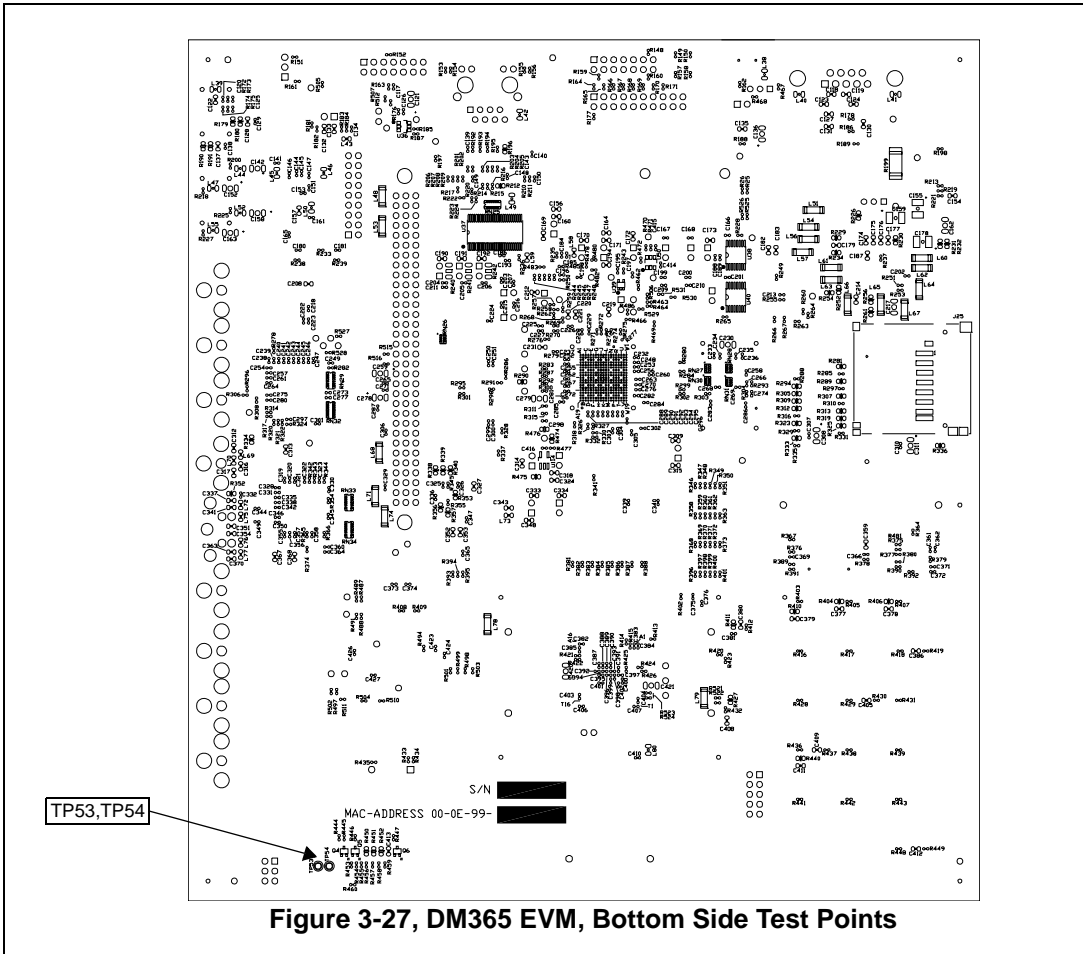

Table 44: DM365 EVM Test Points

Test Point #	Signal	Test Point #	Signal
TP1	GND	TP33	U20, Pin 25, SOGOUT
TP2	GND	TP34	U20, Pin 23, SVSOUT
TP3	MSP430_IO3	TP35	U18-9, C9, LINEO
TP4	MSP430_IO4	TP36	U18-10, A6, ADC_CH5
TP5	VCC_5V	TP37	U18-10, D7, ADC_CH4
TP6	MSP430_IO2	TP38	U20, Pin 80, EXT_CLK
TP7	U5, Pin 25, INT#PHYAD0	TP39	VREF, U18-3, D11
TP8	VCC_3V3, VBUS_OCn2, U4, Pin 5	TP40	GND
TP10	U9, Pin6, PWMON	TP41	GND
TP20	U18-13, L1, MXI1	TP46	U33A, F2, B1.IO_21
TP21	U18-13, K1, MXO1	TP47	U33A, P7, B4.IO_47
TP24	U18-14, R1, RSV1	TP48	U33A, P11, B4.IO_21
TP25	U18-11, K2, PWCTRO0	TP49	U33A, M4, B1.IO_58
TP26	DM360 RESETn, U18-13, H3	TP50	U33A, P2, B1.IO_65
TP27	U18-14, R4, RSV2	TP51	GND
TP28	U18-11, L5, PWCTRO1	TP52	GND
TP30	U18-14, A1, RSV0	TP53	J24, Pin 11,12, BAT_CHG
TP31	U20, Pin 24, HSOUT	TP54	J24, Pin 19
TP32	U20, Pin 22, FIDOUT		

There are 18 power test points on the EVM. These test points provide a convenient mechanism to check the EVM's multiple power supplies. The table below shows the voltages for each test point and what the supply is used for.

Table 45: Power Test Points

Access Test Point	Voltage	Shunt	Power Domain
T1	+1.8V	0.02 ohms	VCC_1V8, U18-14, R12, CPU_VDD_DDR
TP9	+3.3V	0.02 ohms	VCC_3V3, U18-14, P5, CPU_VDDSHV
TP11	+1.2V	0.02 ohms	VCC_1V2, U18-14, R3
TP12	+3.3V	0.02 ohms	VCC_3V3
TP13	+1.8V	0.02 ohms	VCC_1V8
TP14	+1.8V	0.02 ohms	VCC_1V8, U18-14, N4
TP15	+1.2V	0.02 ohms	VCC_1V2, U18-14, J14, CPU_VDD
TP16	+1.8V	0.02 ohms	VCC_1V8, U18-10, G9
TP17	+1.8V	0.02 ohms	VCC_1V8, U18-14, E5
TP18	+1.8V	0.02 ohms	1V8_BB_UP, U18-11, K6
TP19	+1.2V	0.02 ohms	1V2_BB_UP, U18-11, K7,J6
TP22	+1.8V	0.02 ohms	VCC_1V8, U18-9, E9
TP23	+1.8V	0.02 ohms	VCC_1V8, U18-13, L6
TP29	+3.3V	0.02 ohms	VCC_3V3, U18-9, E10
TP42	+3.3V	0.02 ohms	VCC_3V3, U18-14, R14, CPU_VDDSHV10
TP43	+1.8V	0.02 ohms	VCC_1V8, U18-3, D10
TP44	+1.2V	0.02 ohms	VCC_1V2, U18-3, E12
TP45	+1.2V	0.02 ohms	VCC_1V2, U18-14, M14, CPU_VDDS

Appendix A

Schematics

This appendix contains the schematics for the DM365 EVM.

REV	DESCRIPTION	DATE	APPROVED
A	Initial schematic ready for layout - Alpha Release	03/04/08	RRP
B	Updates for initial prototype build	09/24/08	RRP
C	BETA Release	10/30/08	RRP

REVISION STATUS OF EVM

Assembly	Part Number	Rev
Assembly	510840-0001	C
PWB	510841-0001	C
LOGIC	510842-0001	C

REVISION STATUS OF SHEETS

REV	C	C	C	C	C	C	C	C	C	C	C	C	C	C	C	C	C	C	C	C
SHEET	51	52	53																	
SHEET	41	42	43	44	45	46	47	48	49	50										
SHEET	31	32	33	34	35	36	37	38	39	40										

SCHEMATIC CONTENTS

SHEET01 - TITLE SHEET
 SHEET02 - DM365 DDR2 INTERFACE
 SHEET03 - DM365 EMIF/BOOT MODES/CFG MODES
 SHEET04 - DM365 USB
 SHEET05 - DM365 VIDEO PORT IN
 SHEET06 - DM365 VIDEO PORT OUT
 SHEET07 - DM365 ANALOG VIDEO OUT
 SHEET08 - DM365 SD/MMC/MS IF
 SHEET09 - DM365 I/O
 SHEET10 - DM365 JTAG,CLKS,RESET
 SHEET11 - DM365 ADC
 SHEET12 - DM365 MIC/SPEAKER
 SHEET13 - DM365 POWER PINS
 SHEET14 - DM365 POWER CONTROL
 SHEET15 - DM365 GROUND PINS
 SHEET16 - DM365 DECOUPLING CAPS
 SHEET17 - DDR2 MEMORY
 SHEET18 - USB INTERFACE CONNECTOR
 SHEET19 - JTAG CONNECTORS
 SHEET20 - CPLD BANK A
 SHEET21 - CPLD BANK B
 SHEET22 - CPLD BANK C
 SHEET23 - CPLD BANK D
 SHEET24 - CLPD POWER
 SHEET25 - HOST/EMIF DC INTERFACE
 SHEET26 - NAND FLASH
 SHEET27 - ONE NAND
 SHEET28 - I2C/SPI EEPROM
 SHEET29 - RS232 INTERFACE
 SHEET30 - SD/MMC/MS IF
 SHEET31 - SD.MMC IF 2
 SHEET32 - VIDEO COMPONENT OUT
 SHEET33 - VIDEO INPUT MULTIPLEXER
 SHEET34 - VIDEO INPUT DC CONNECTORS
 SHEET35 - TVP7002
 SHEET36 - HD VIDEO IN CONNECTORS
 SHEET37 - TVP5146 DECODER
 SHEET38 - McBSP MUX
 SHEET39 - AIC3101
 SHEET40 - VIDEO DC OUTPUT CONNECTORS
 SHEET41 - DILC HOST CONNECTOR
 SHEET42 - ETHERNET MUX
 SHEET43 - ETHERNET PHY
 SHEET44 - MSP430 IR CONTROLLER
 SHEET45 - SWITCHES
 SHEET46 - LEDES
 SHEET47- POWER SUPPLY TP65510
 SHEET48 - POWER SUPPLY TP65530
 SHEET49 - POWER SUPPLY
 SHEET50 - DECODER 3V3, 1V8 POWER
 SHEET51 - ALT CPU CORE POWER
 SHEET52 - ALT 3V3 POWER
 SHEET53 - POWER IN

I2C ADDRESS	Device	Address
0x18	AIC3101	
0x25	MSP430	
0x2C	THS7303	
0x2E	THS7353	
0x50	CAT24C256	
0x5D	TVP5146	
0x5C	TVP7002	

NEXT ASSY USED ON		REV	R.R.P.	DATE
		RRP	03/04/2008	DATE
		T.W.K.	03/04/2008	DATE
		RRP	03/04/2008	DATE
		RRP-MKR	03/04/2008	DATE
		JA	03/04/2008	DATE
		C.M.G.	03/04/2008	DATE
		RRP	03/04/2008	DATE
		ELSE	03/04/2008	DATE

SPECTRUM DIGITAL INCORPORATED			
Title: DM365 Evaluation Module			
Page Contents: TITLE SHEET			
Size: B	DWG NO	510842-0001	Revision: C
Date:	Monday, April 13, 2009	Sheet	1 of 53

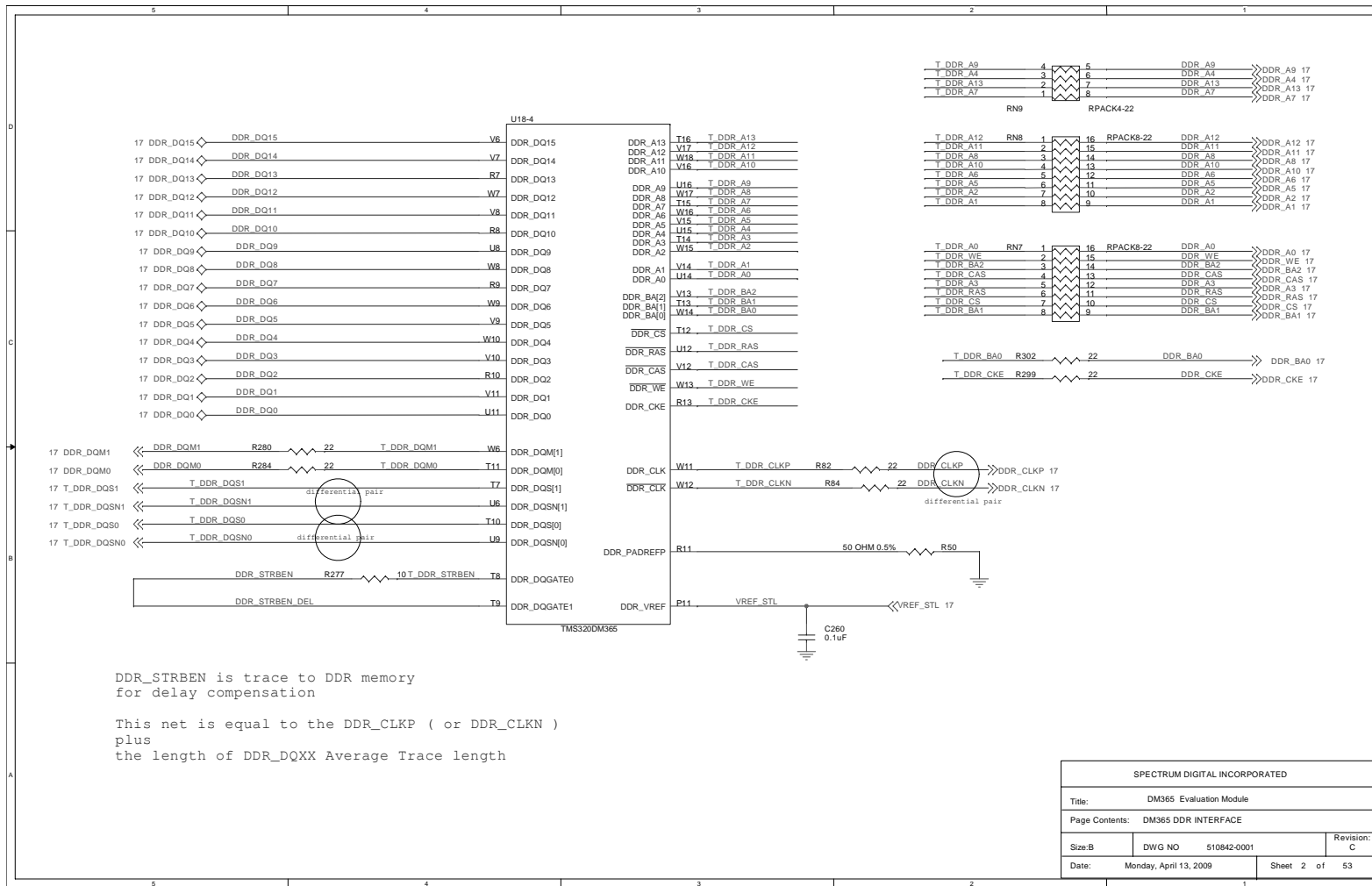

Spectrum Digital, Inc

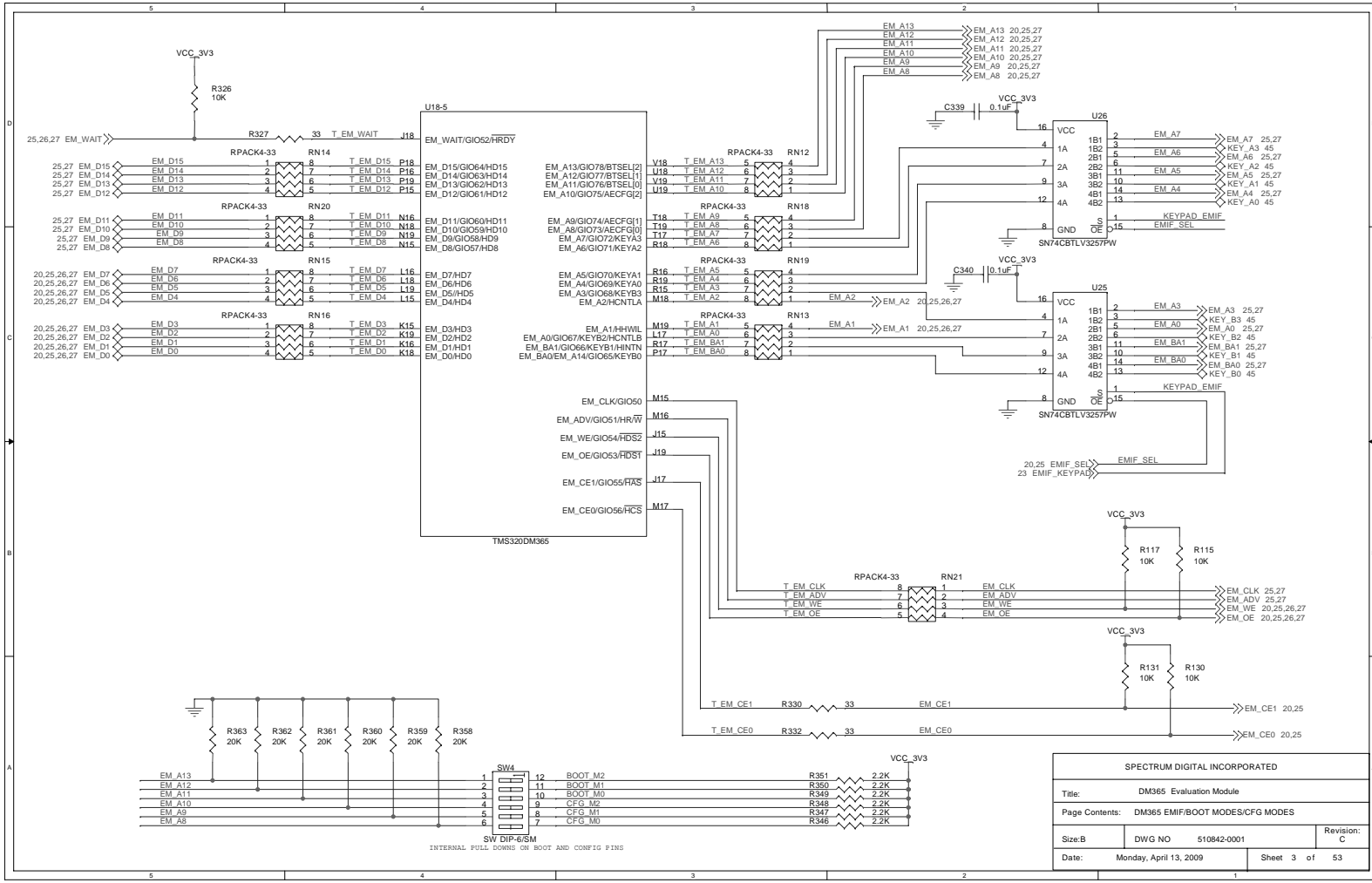

SPECTRUM DIGITAL INCORPORATED			
Title: DM365 Evaluation Module			
Page Contents: DM365 EMIF/BOOT MODES/CFG MODES			
Size: B	DWG NO	510842-0001	Revision: C
Date: Monday, April 13, 2009	Sheet 3 of 53		

A-4

DM365 EVM Technical Reference

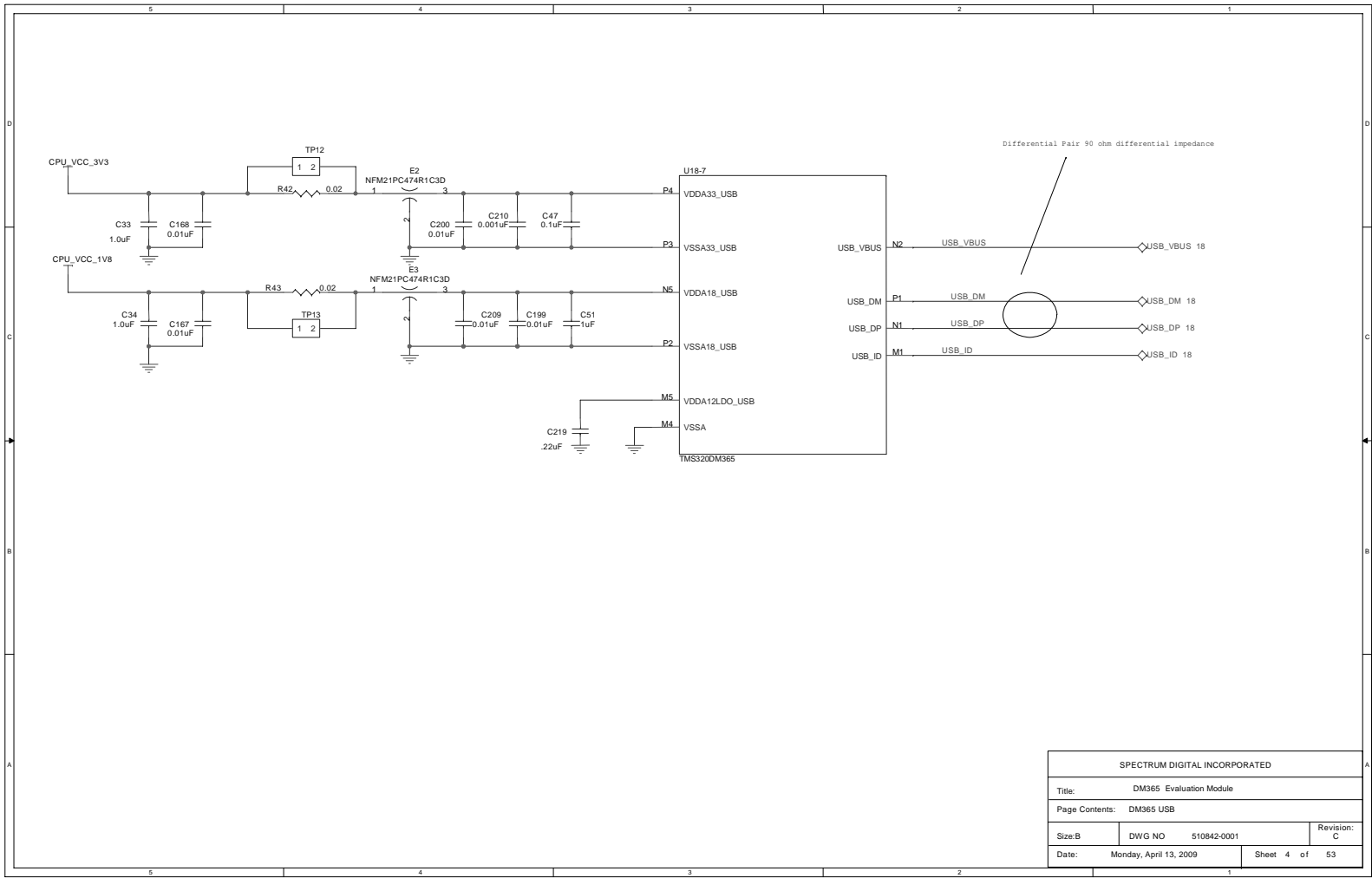

SPECTRUM DIGITAL INCORPORATED			
Title: DM365 Evaluation Module			
Page Contents: DM365 USB			
Size: B	DWG NO	510842-0001	Revision: C
Date:	Monday, April 13, 2009	Sheet 4 of	53

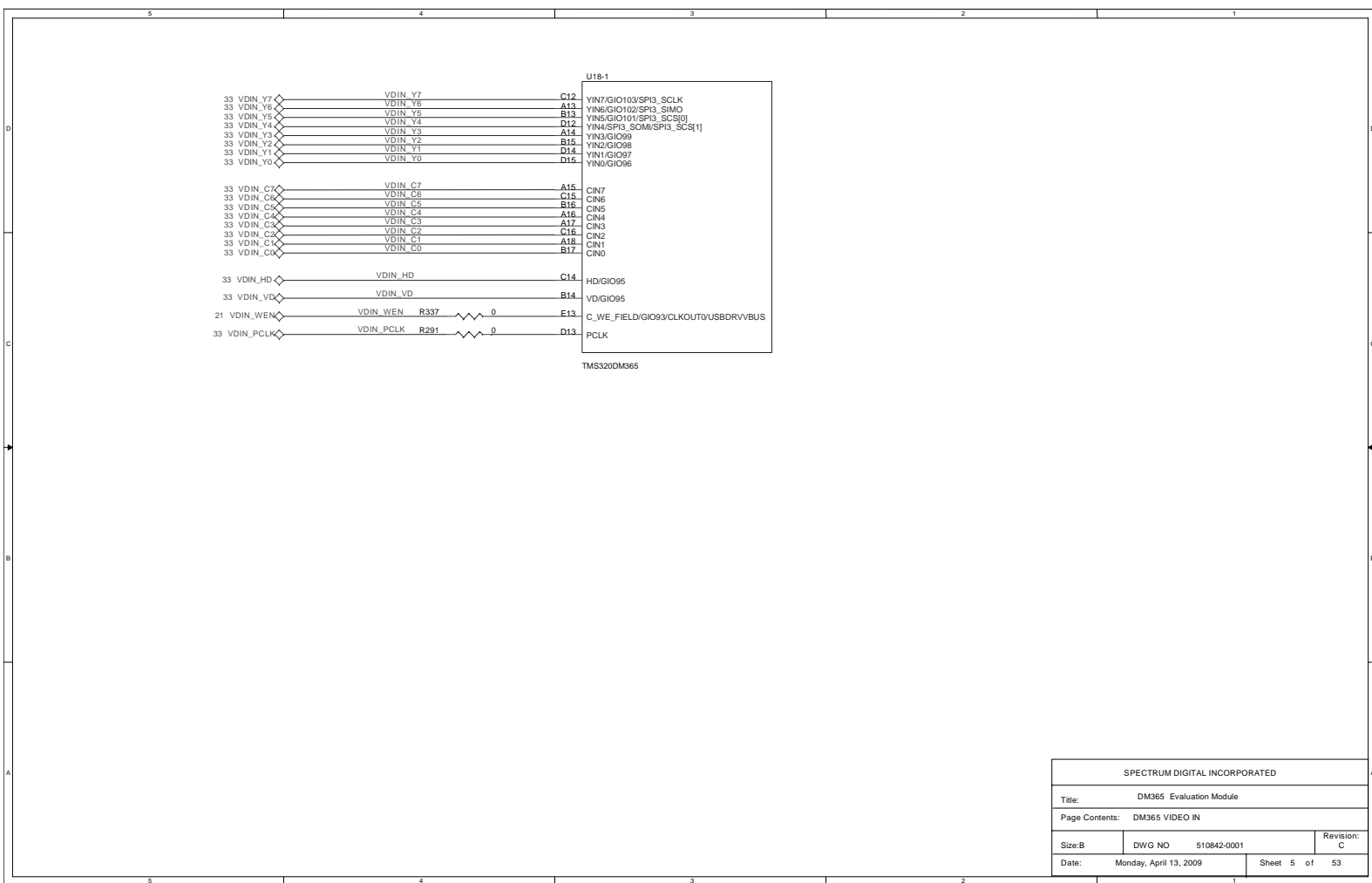

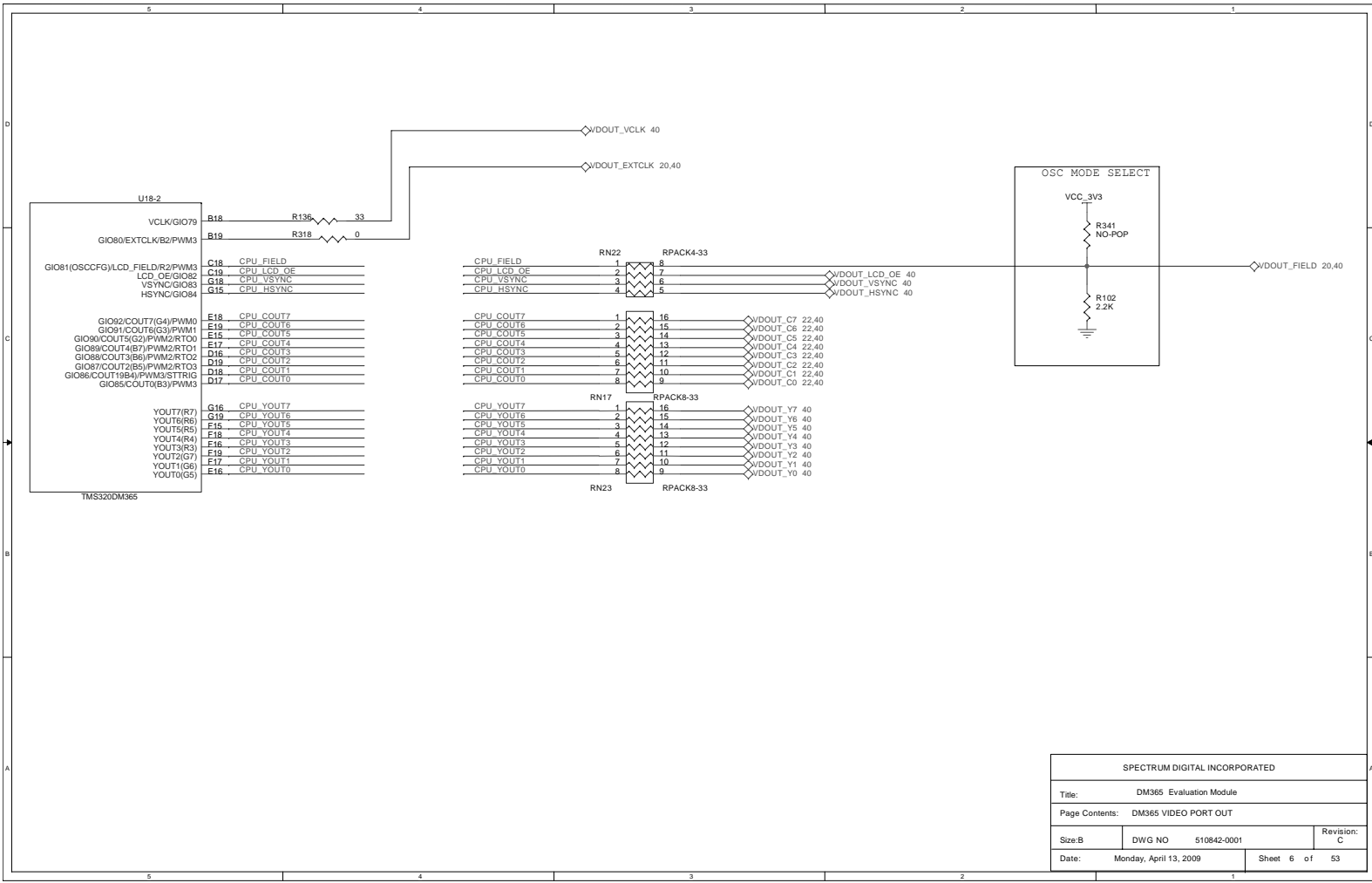

SPECTRUM DIGITAL INCORPORATED			
Title: DM365 Evaluation Module			
Page Contents: DM365 VIDEO PORT OUT			
Size: B	DWG NO: 510842-0001	Revision: C	
Date: Monday, April 13, 2009	Sheet 6 of 53		

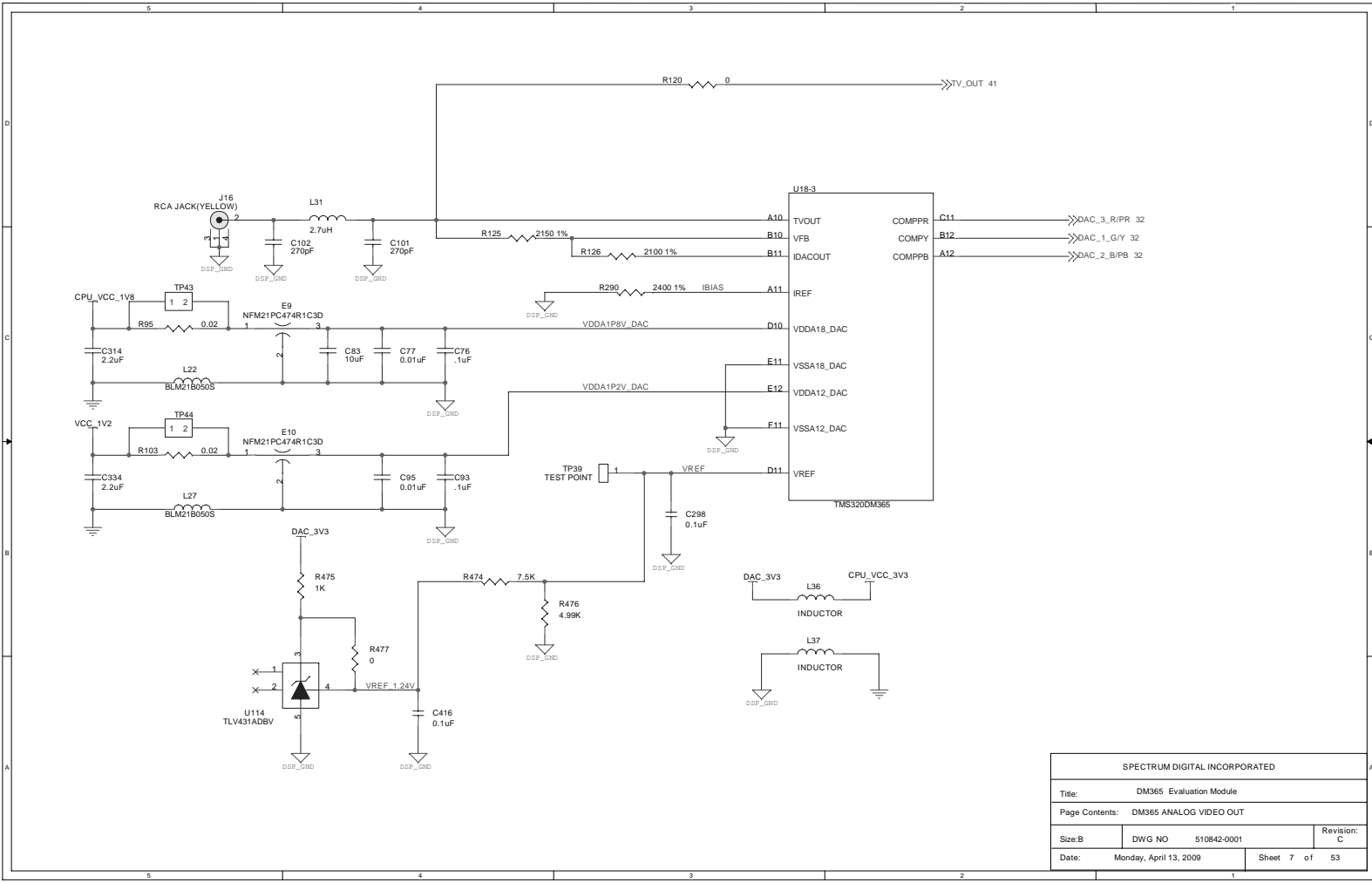

SPECTRUM DIGITAL INCORPORATED			
Title: DM365 Evaluation Module			
Page Contents: DM365 ANALOG VIDEO OUT			
Size: B	DWG NO: 510842-0001	Revision: C	
Date: Monday, April 13, 2009	Sheet 7 of 53		

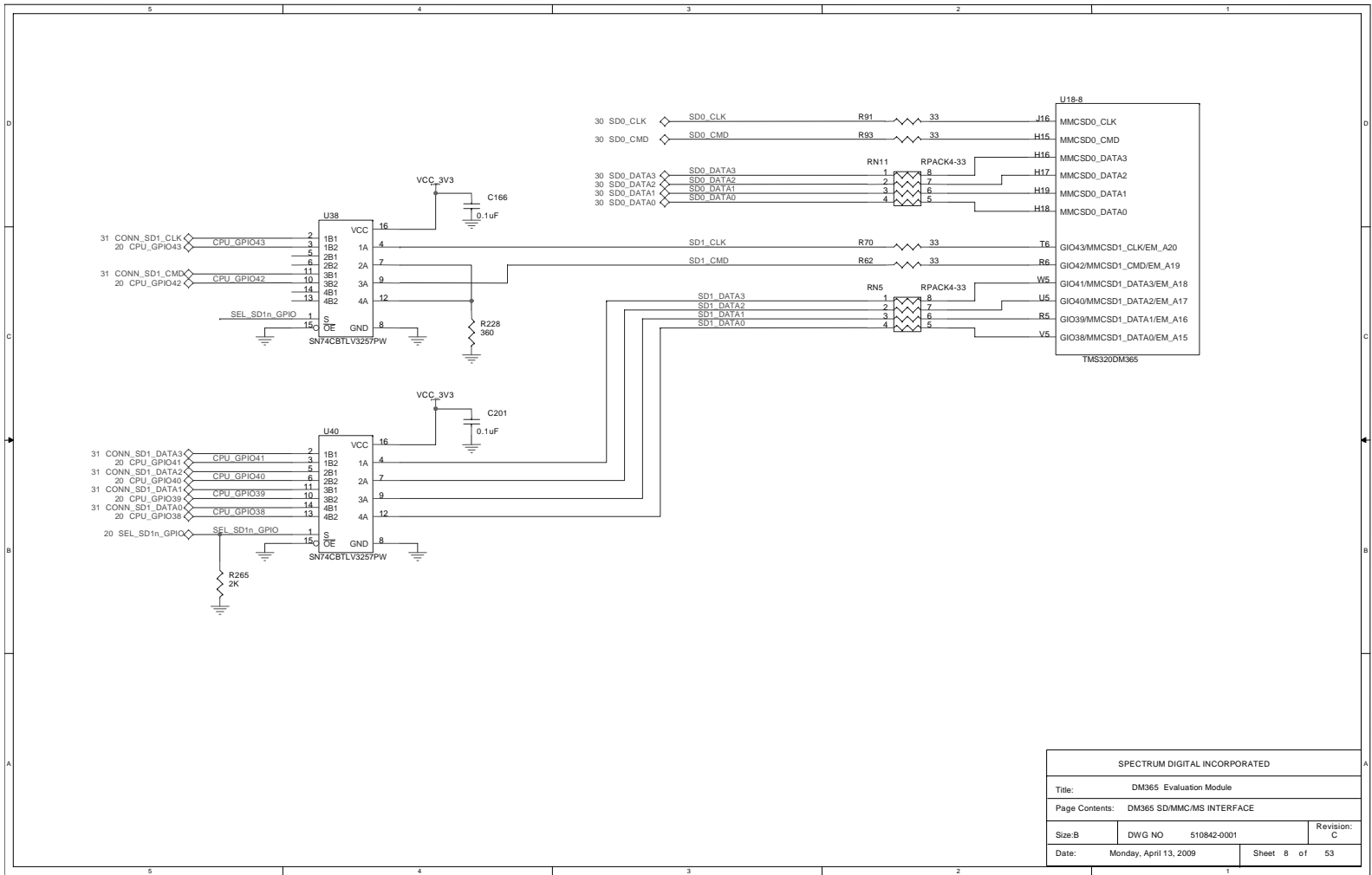

SPECTRUM DIGITAL INCORPORATED			
Title: DM365 Evaluation Module			
Page Contents: DM365 SD/MMC/MS INTERFACE			
Size: B	DWG NO: 510842-0001	Revision: C	
Date: Monday, April 13, 2009	Sheet 8 of 53		

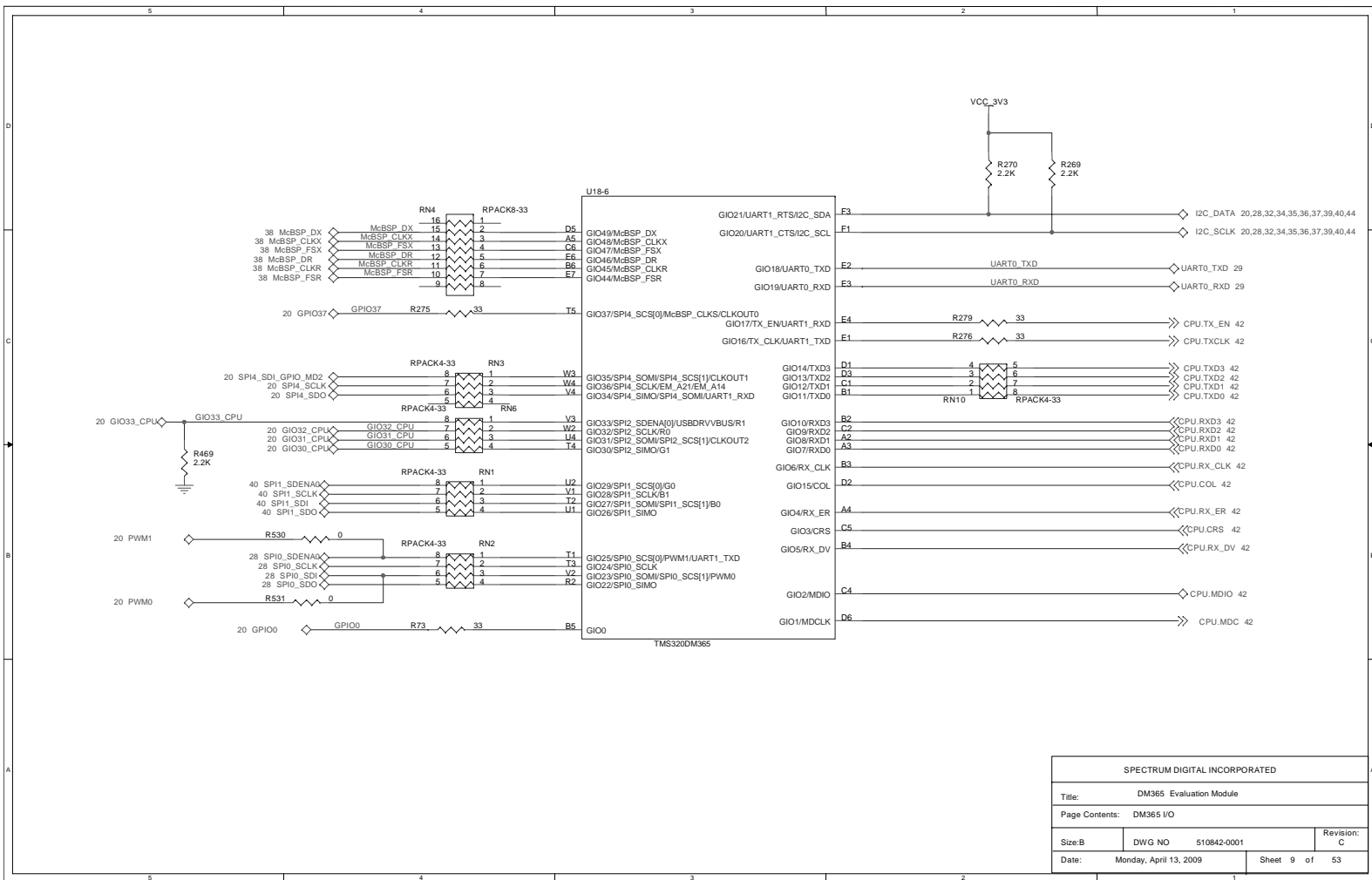

SPECTRUM DIGITAL INCORPORATED		
Title: DM365 Evaluation Module		
Page Contents: DM365 I/O		
Size: B	DWG NO 510842-0001	Revision: C
Date: Monday, April 13, 2009	Sheet 9 of 53	

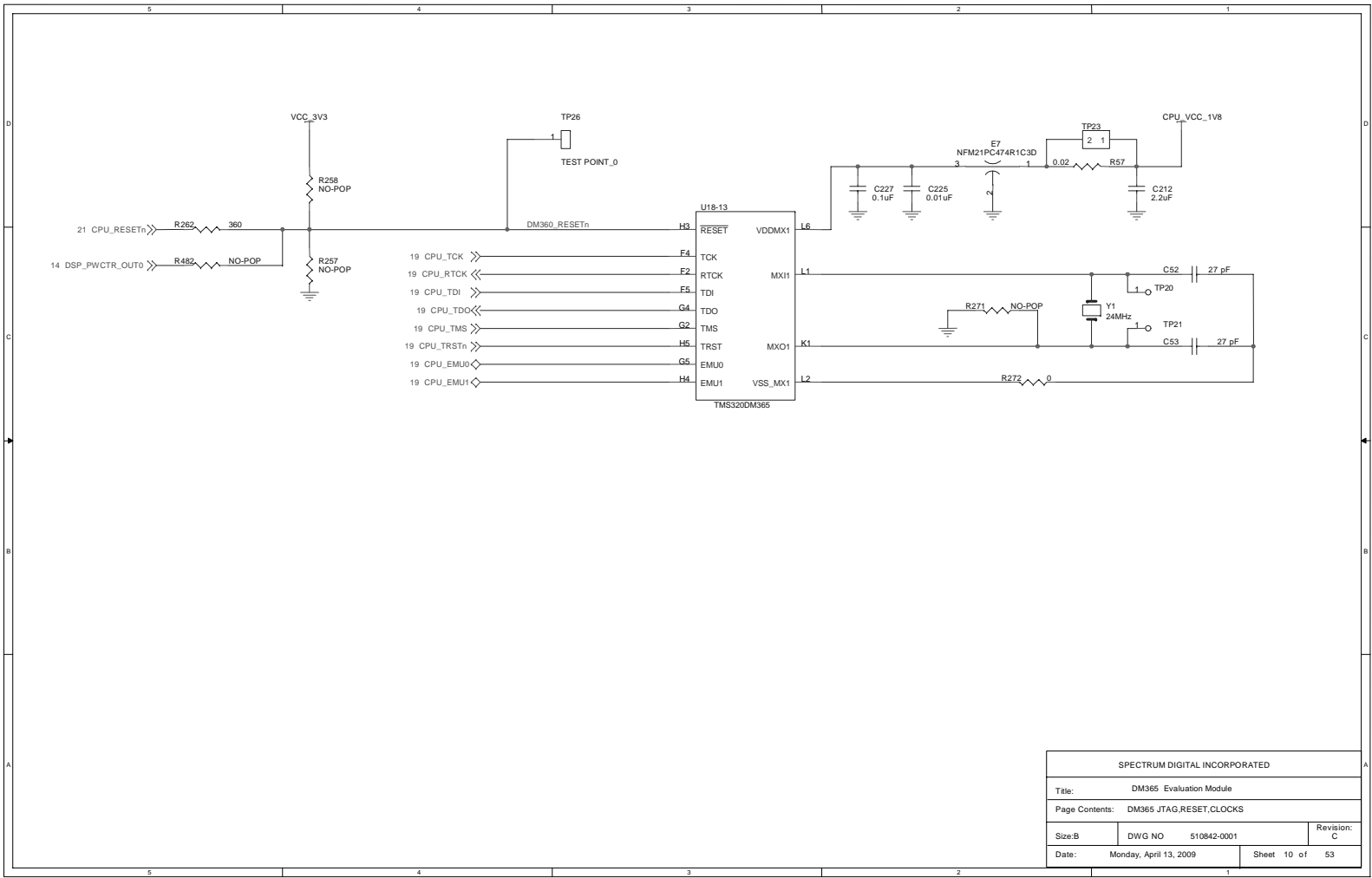

SPECTRUM DIGITAL INCORPORATED			
Title: DM365 Evaluation Module			
Page Contents: DM365 JTAG, RESET, CLOCKS			
Size: B	DWG NO	510842-0001	Revision: C
Date:	Monday, April 13, 2009	Sheet	10 of 53

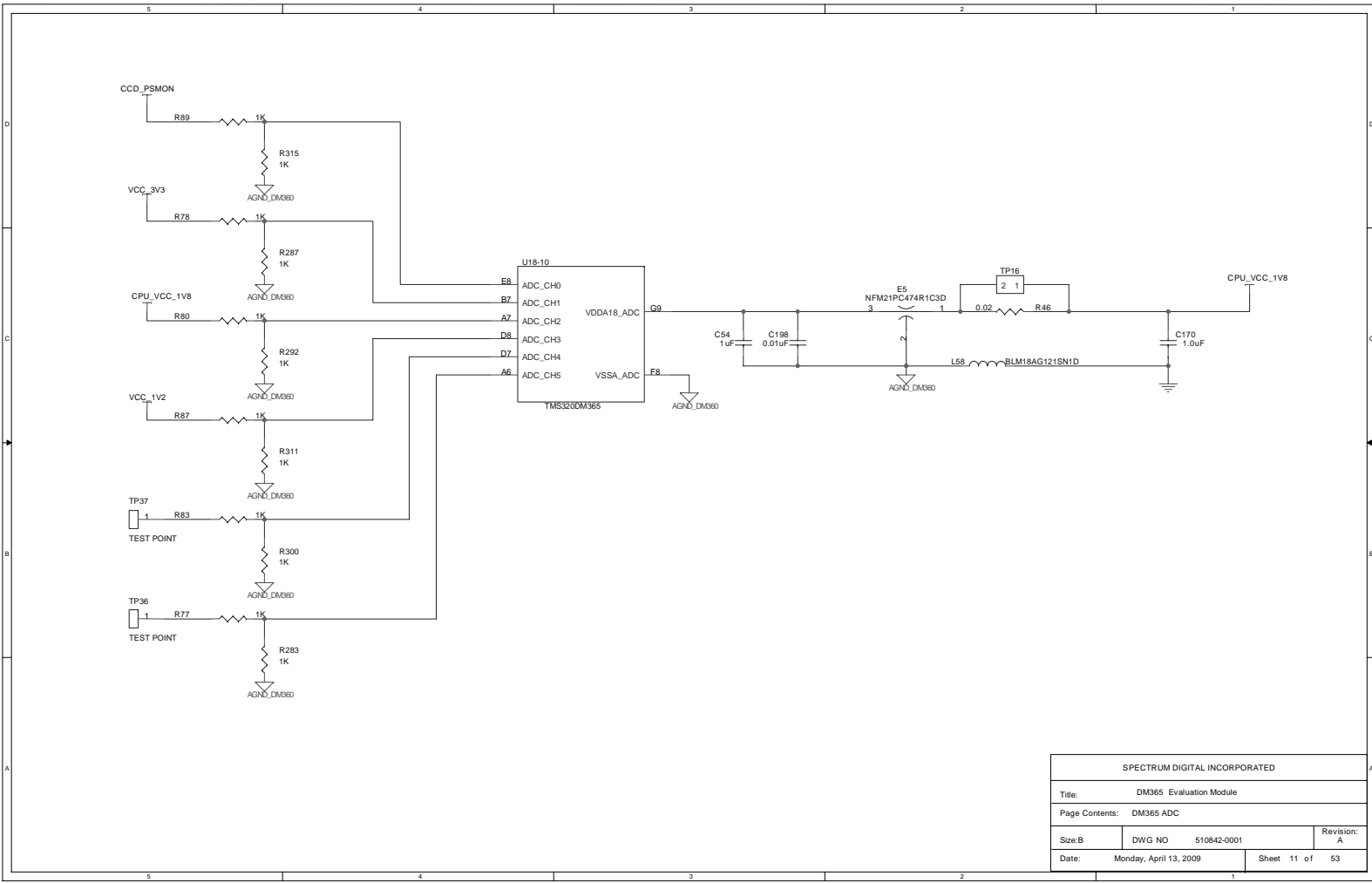

SPECTRUM DIGITAL INCORPORATED		
Title: DM365 Evaluation Module		
Page Contents: DM365 ADC		
Size: B	DWG NO: 510842-0001	Revision: A
Date: Monday, April 13, 2009	Sheet 11 of 53	

A-12

DM365 EVM Technical Reference

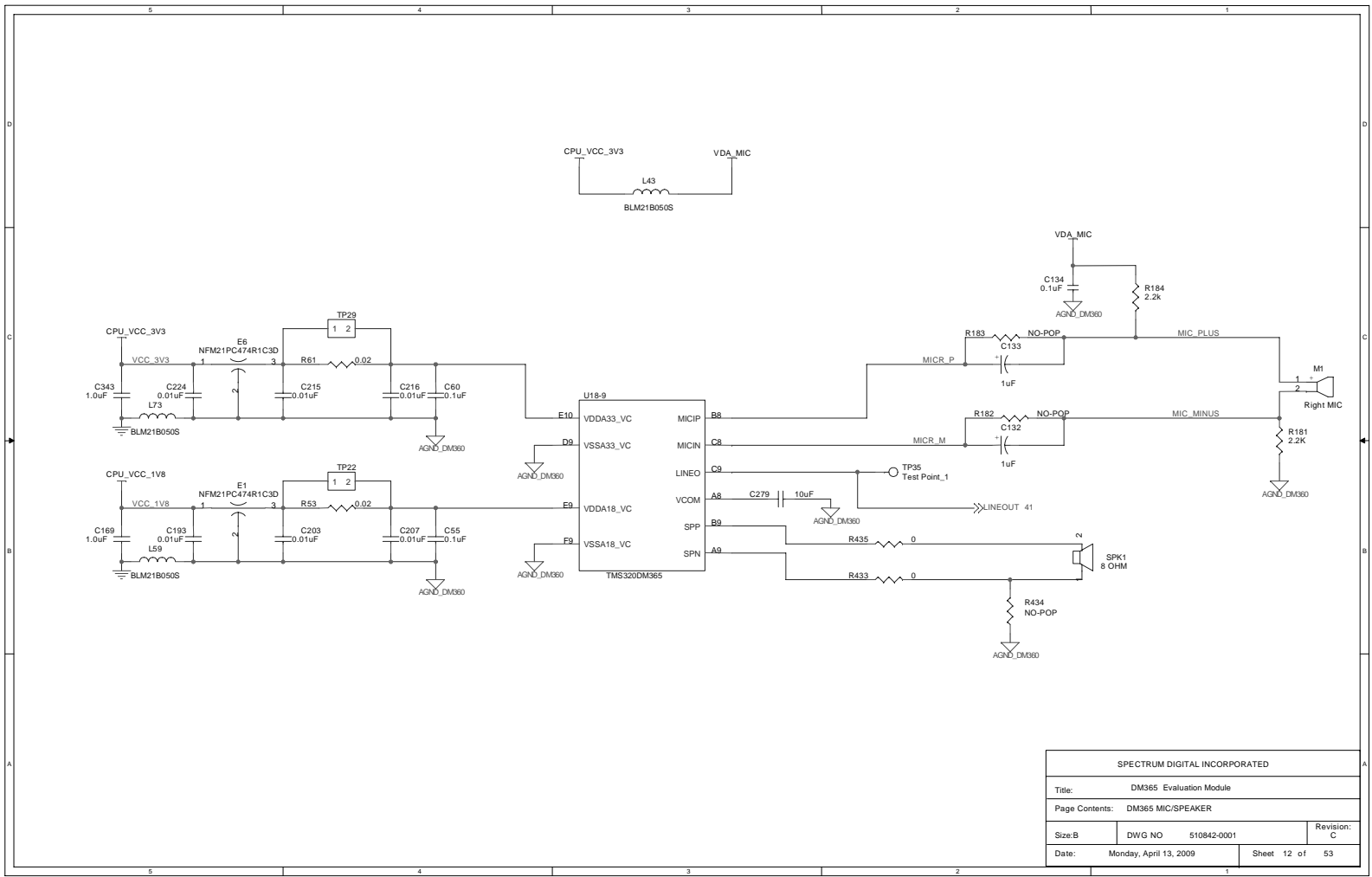

SPECTRUM DIGITAL INCORPORATED			
Title: DM365 Evaluation Module			
Page Contents: DM365 MIC/SPEAKER			
Size: B	DWG NO	510842-0001	Revision: C
Date:	Monday, April 13, 2009	Sheet 12 of	53

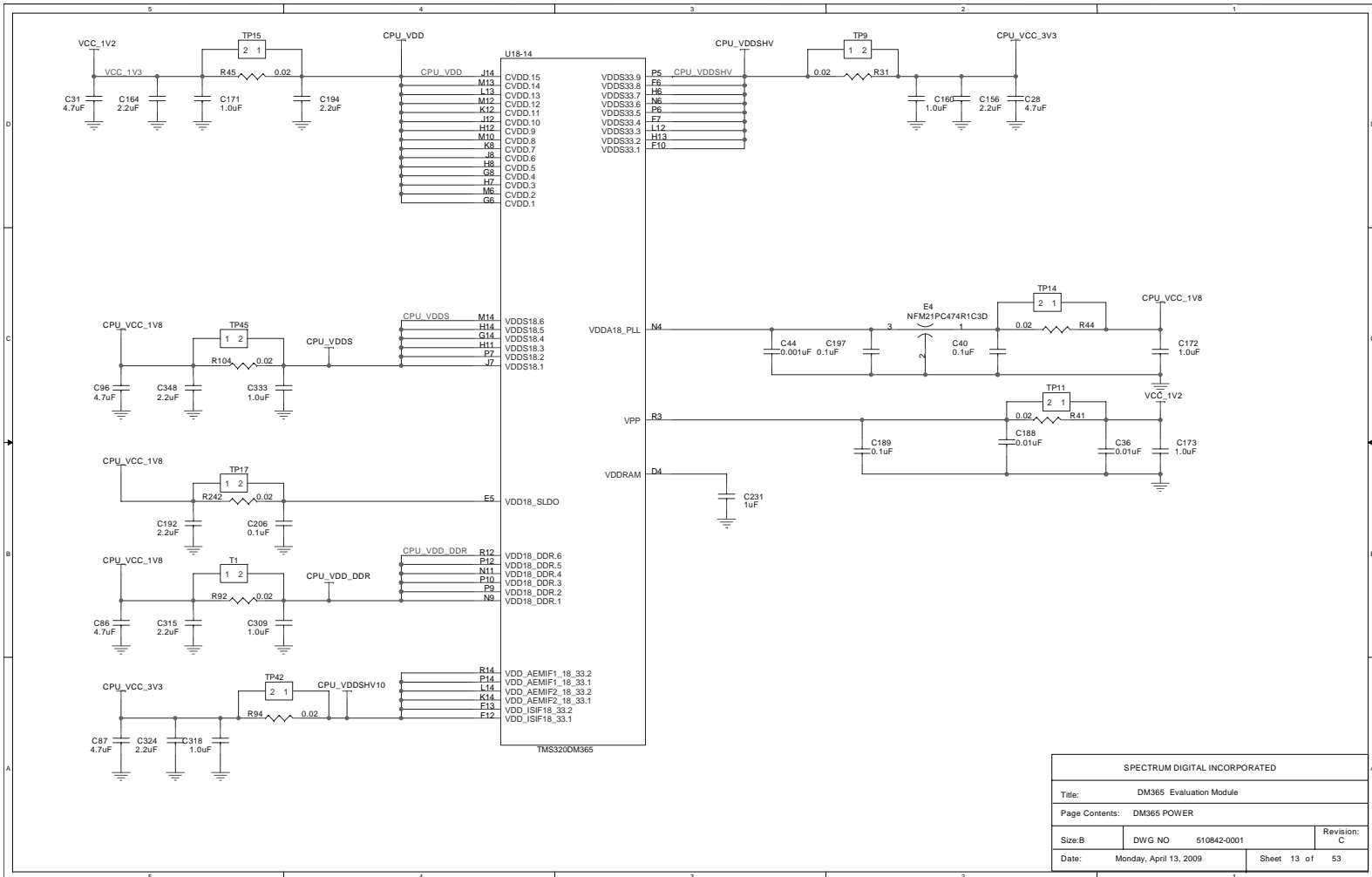

SPECTRUM DIGITAL INCORPORATED			
Title: DM365 Evaluation Module			
Page Contents: DM365 POWER			
Size: B	DWG NO	510842-0001	Revision: C
Date: Monday, April 13, 2009	Sheet 13 of 53		

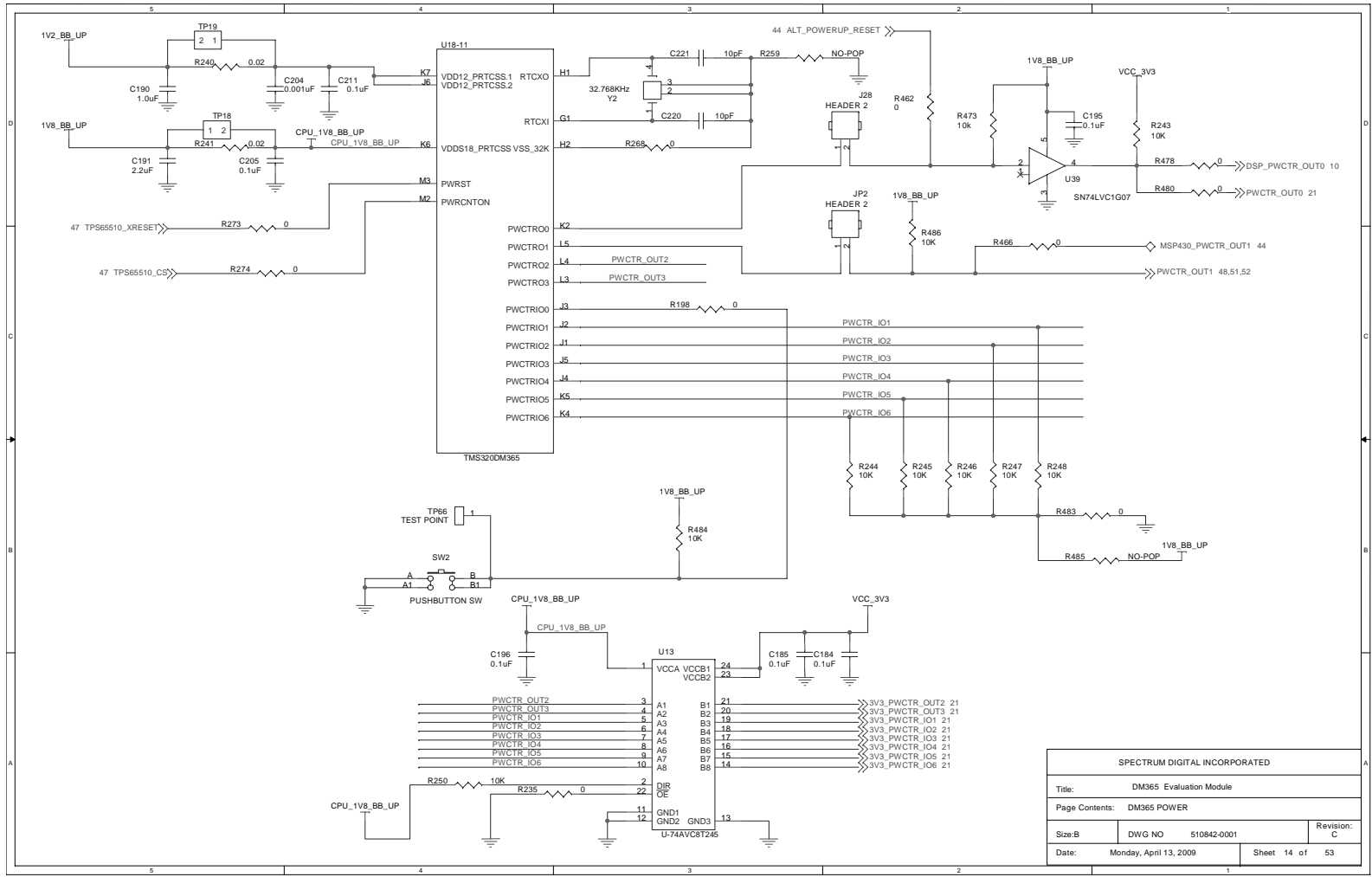

SPECTRUM DIGITAL INCORPORATED			
Title: DM365 Evaluation Module			
Page Contents: DM365 POWER			
Size: B	DWG NO	510842-0001	Revision: C
Date: Monday, April 13, 2009	Sheet 14 of		53

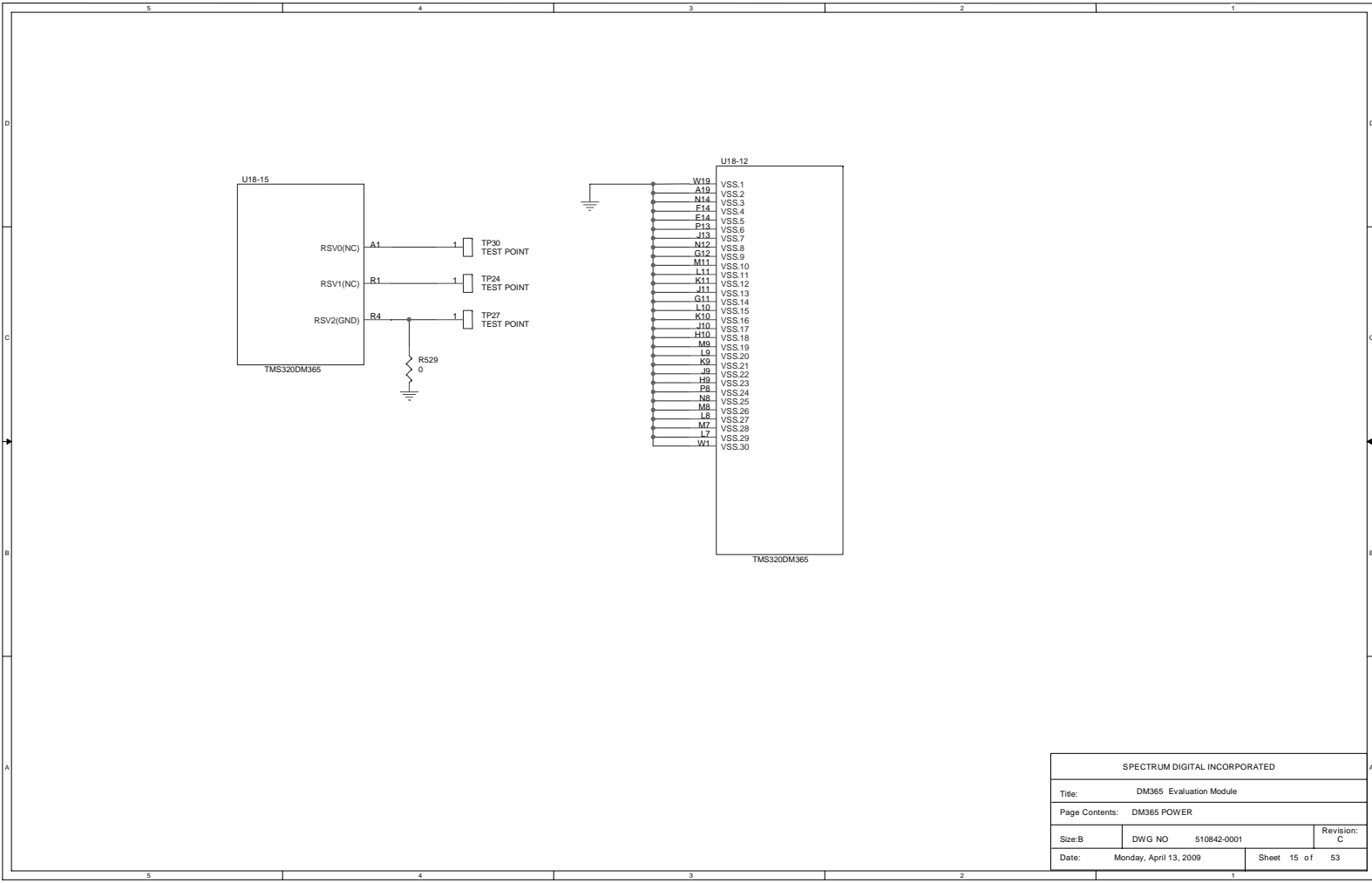

SPECTRUM DIGITAL INCORPORATED			
Title: DM365 Evaluation Module			
Page Contents: DM365 POWER			
Size: B	DWG NO	510842-0001	Revision: C
Date:	Monday, April 13, 2009	Sheet	15 of 53

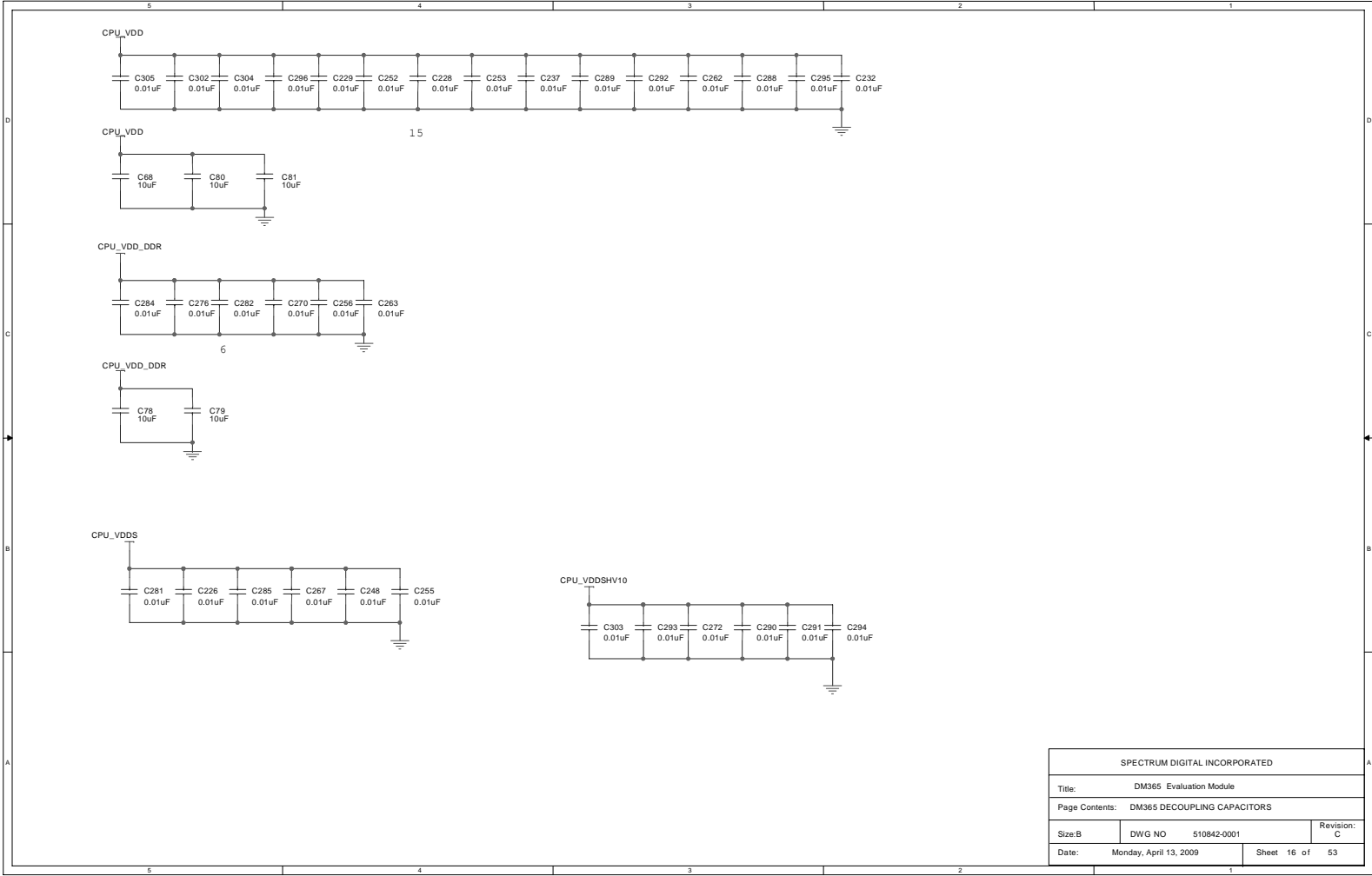

SPECTRUM DIGITAL INCORPORATED		
Title: DM365 Evaluation Module		
Page Contents: DM365 DECOUPLING CAPACITORS		
Size: B	DWG NO 510842-0001	Revision: C
Date: Monday, April 13, 2009	Sheet 16 of	53

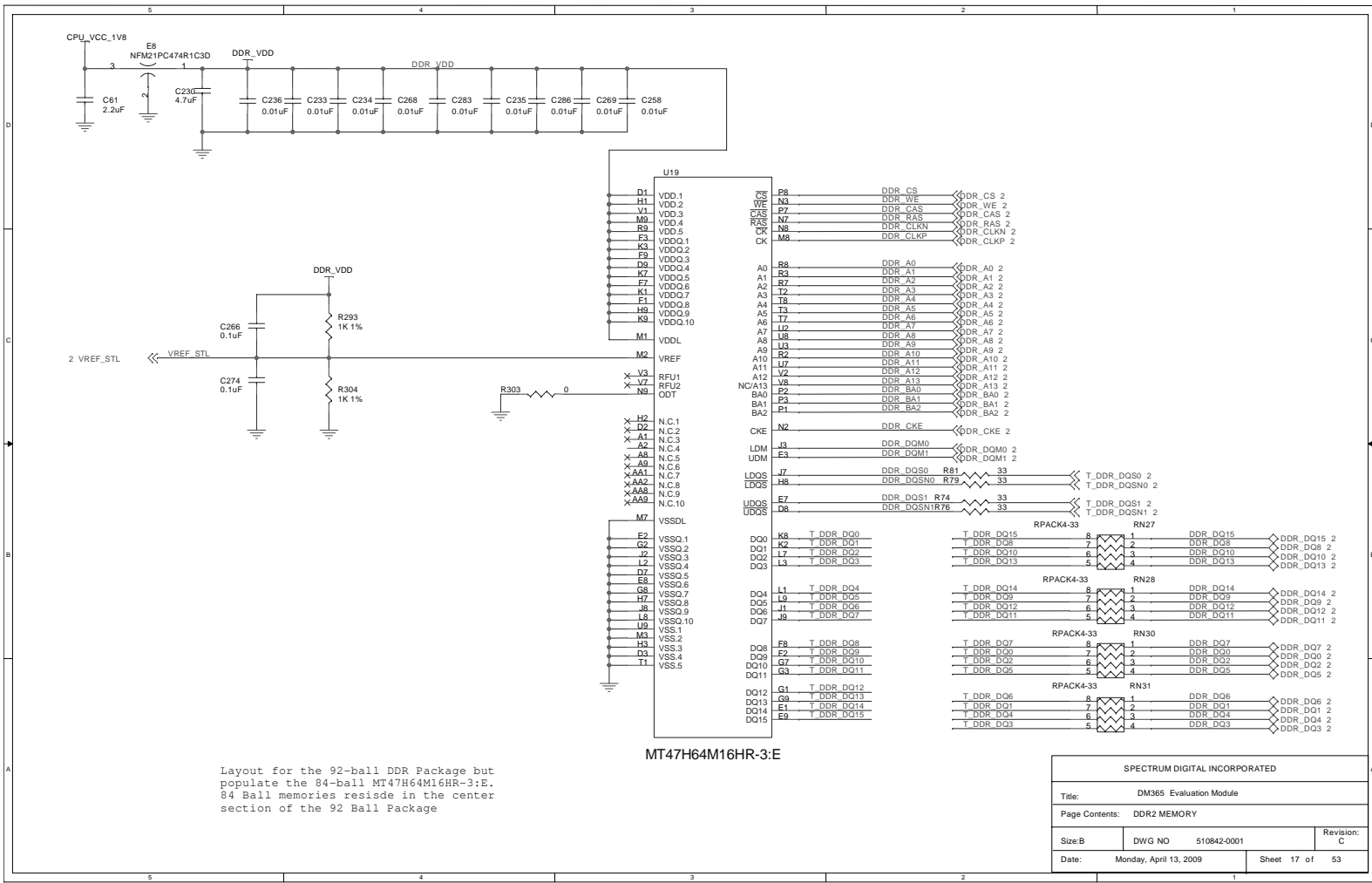

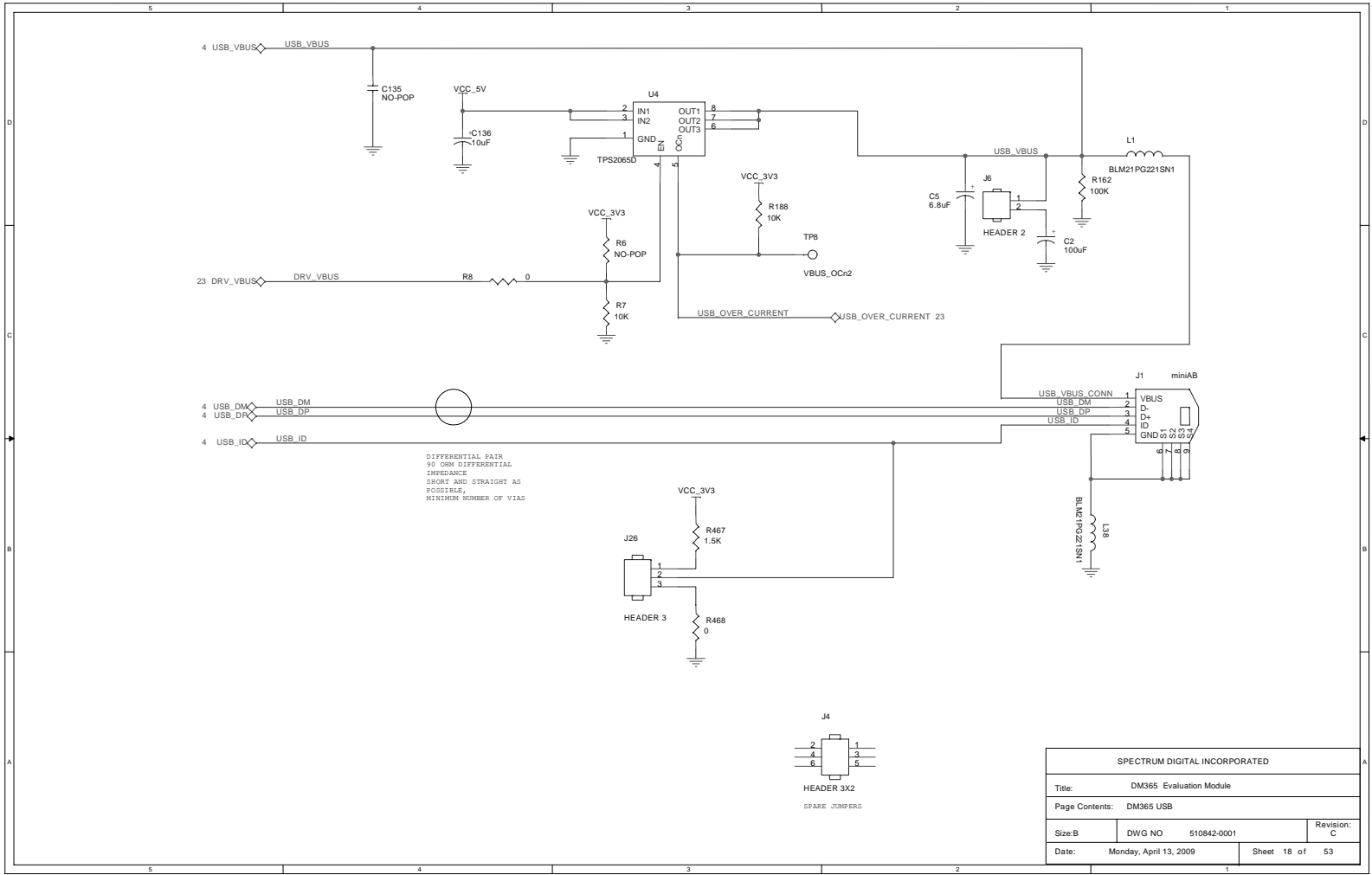

Spectrum Digital, Inc

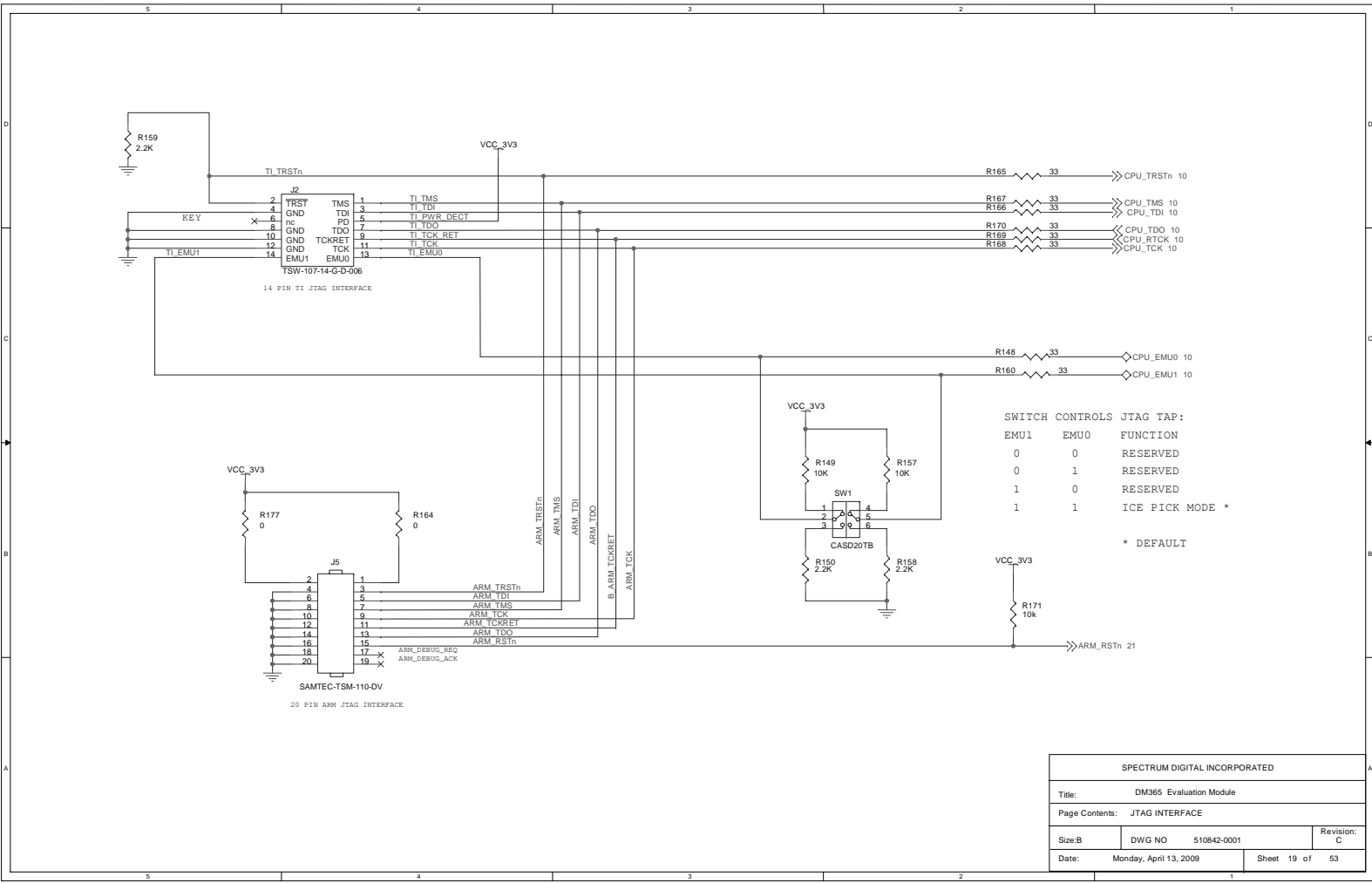

SPECTRUM DIGITAL INCORPORATED			
Title: DM365 Evaluation Module			
Page Contents: JTAG INTERFACE			
Size: B	DWG NO	510842-0001	Revision: C
Date:	Monday, April 13, 2009	Sheet	19 of 53

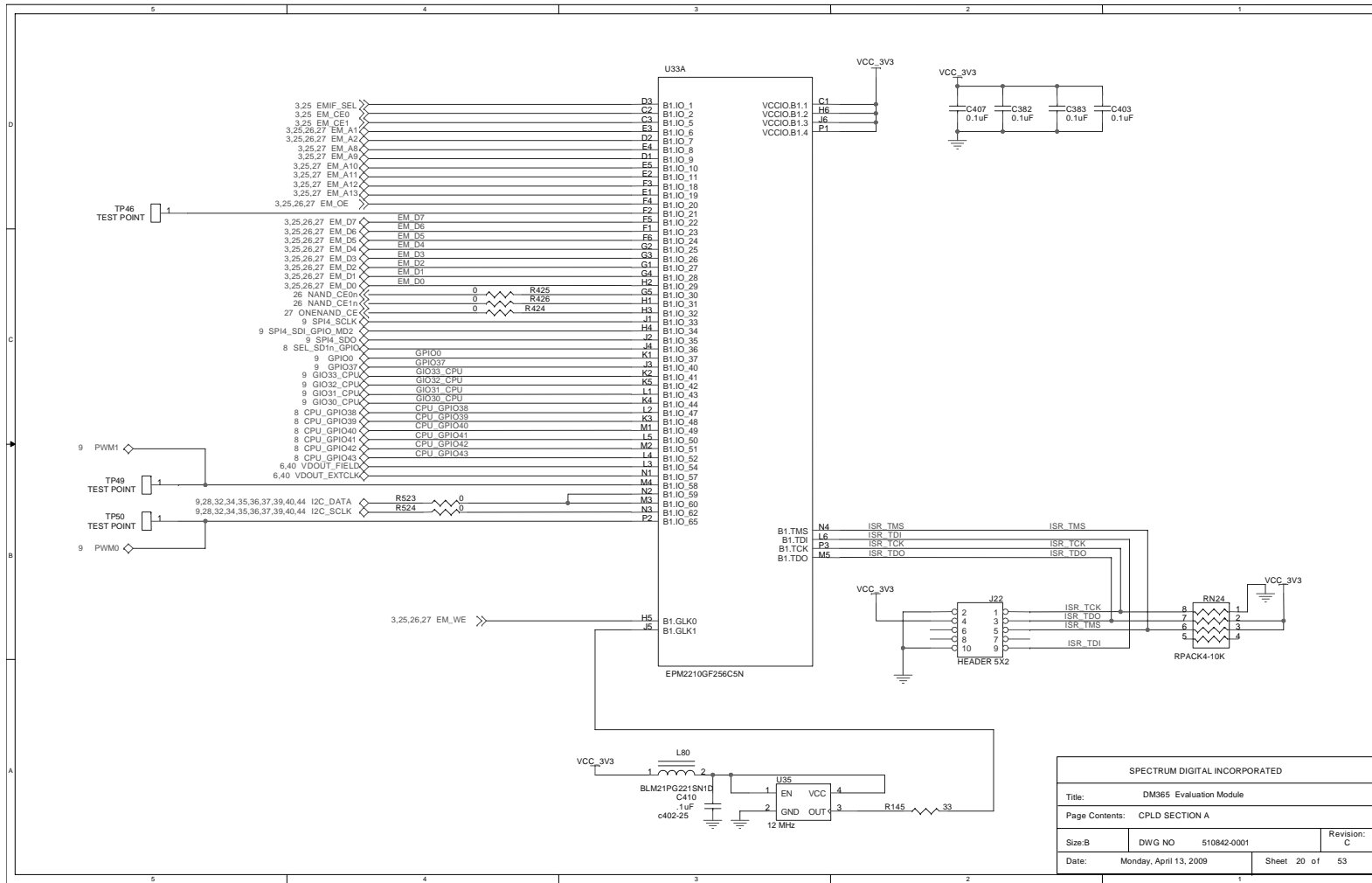

SPECTRUM DIGITAL INCORPORATED			
Title: DM365 Evaluation Module			
Page Contents: CPLD SECTION A			
Size: B	DWG NO: 510842-0001	Revision: C	
Date: Monday, April 13, 2009	Sheet 20 of 53		

Spectrum Digital, Inc

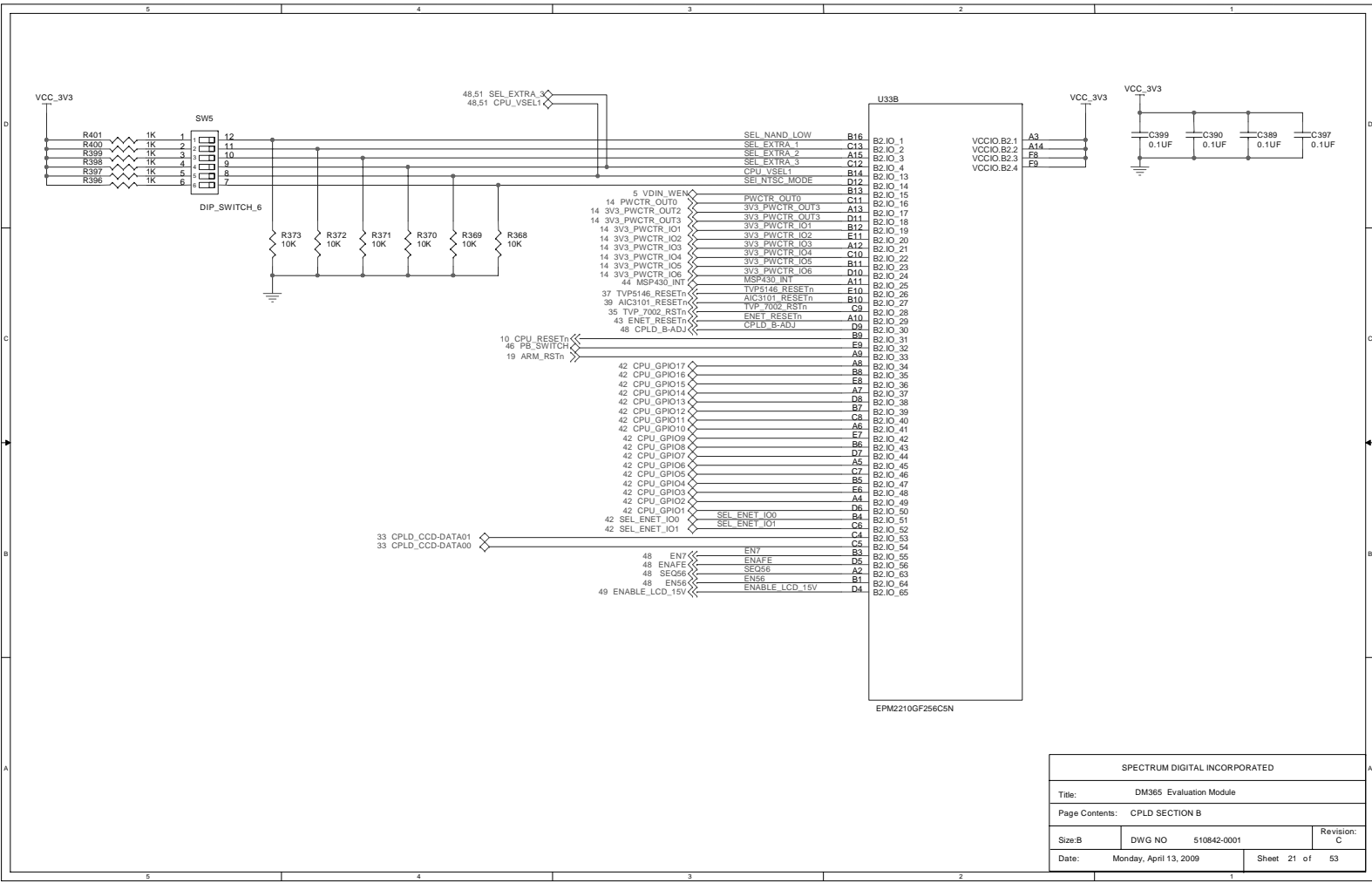

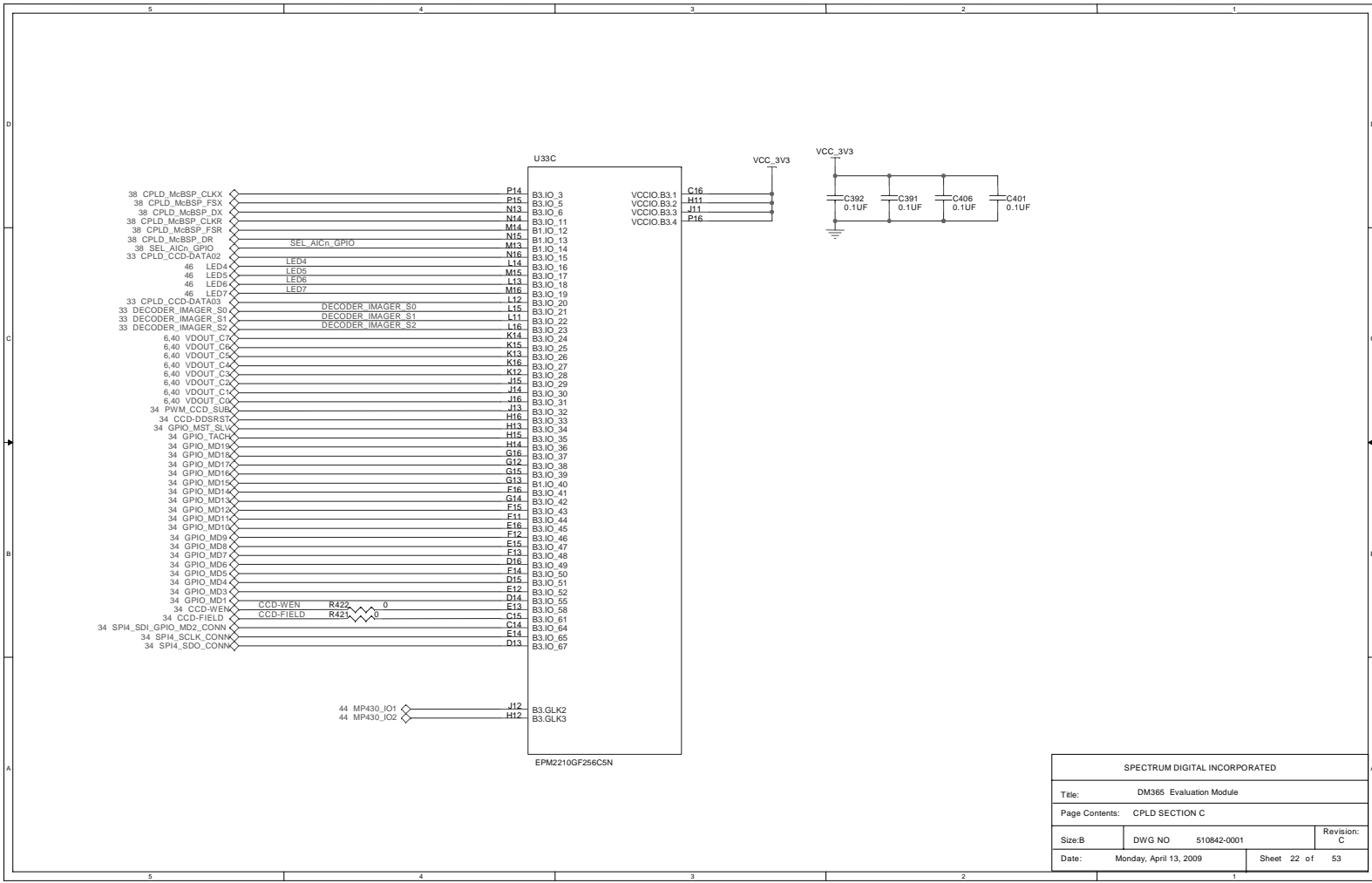

SPECTRUM DIGITAL INCORPORATED			
Title: DM365 Evaluation Module			
Page Contents: CPLD SECTION C			
Size: B	DWG NO	510842-0001	Revision: C
Date:	Monday, April 13, 2009	Sheet	22 of 53

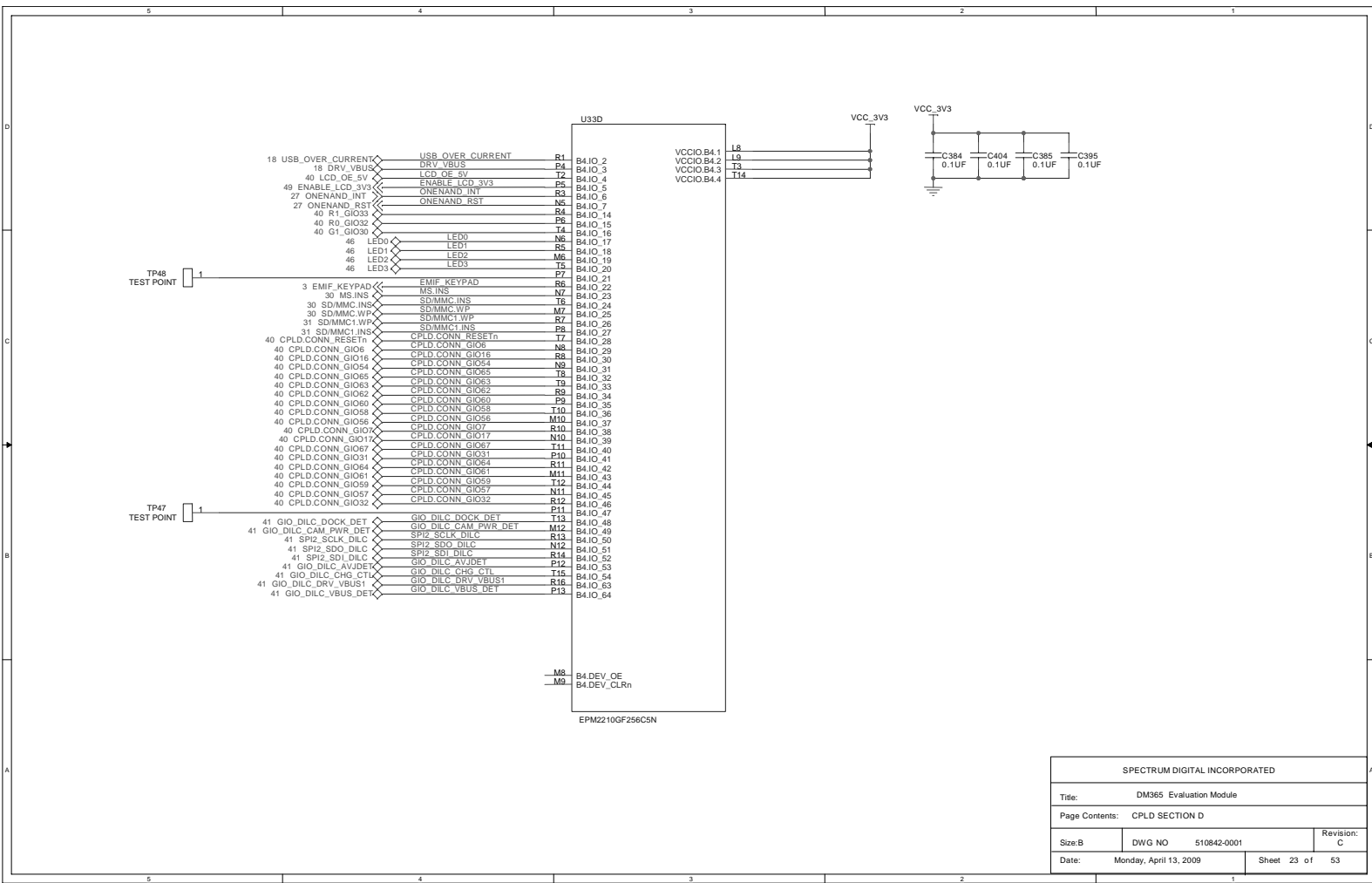

A-24

DM365 EVM Technical Reference

SPECTRUM DIGITAL INCORPORATED			
Title: DM365 Evaluation Module			
Page Contents: CPLD SECTION D			
Size: B	DWG NO	510842-0001	Revision: C
Date: Monday, April 13, 2009	Sheet 23 of		53

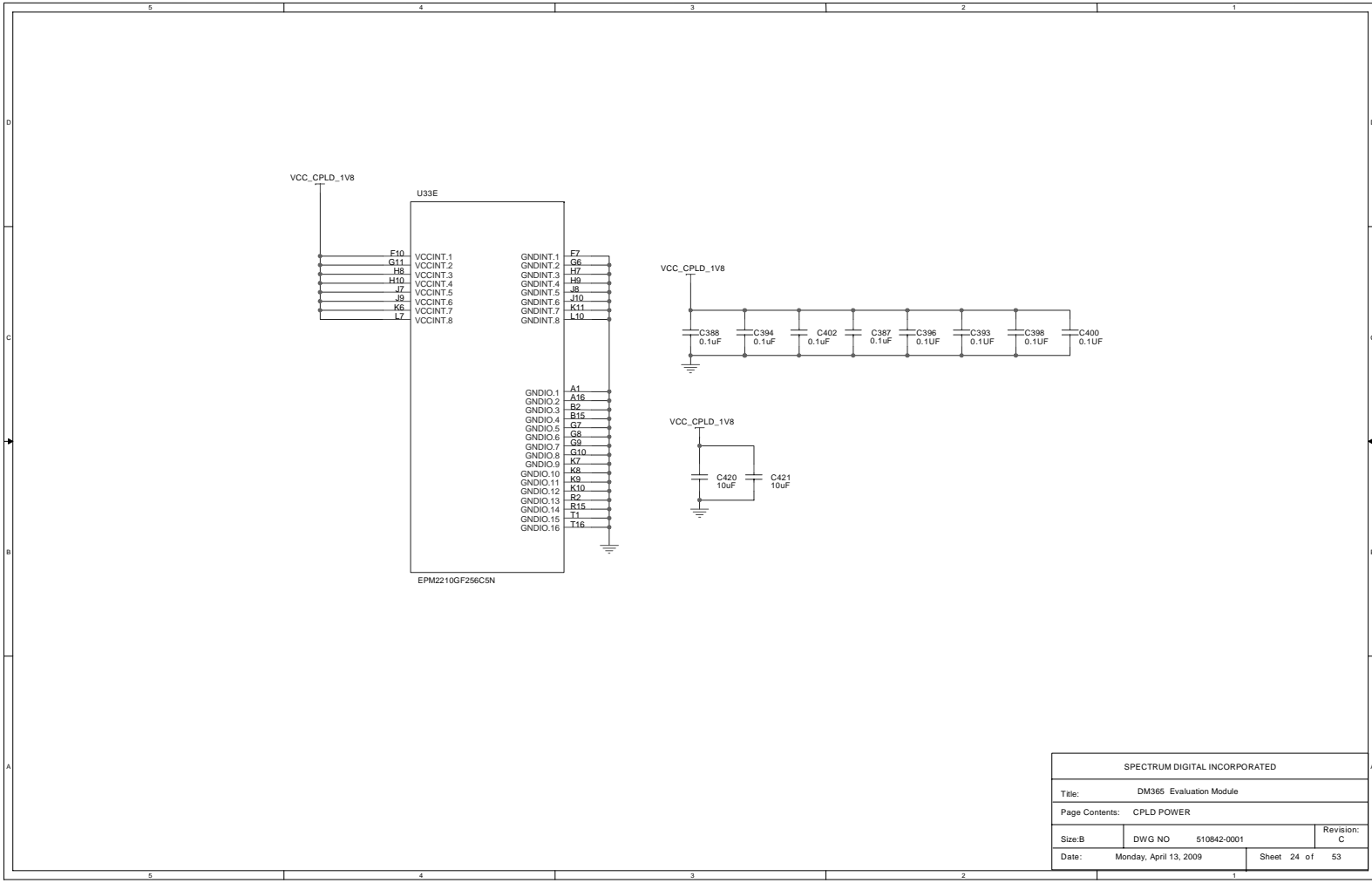

SPECTRUM DIGITAL INCORPORATED			
Title: DM365 Evaluation Module			
Page Contents: CPLD POWER			
Size: B	DWG NO	510842-0001	Revision: C
Date:	Monday, April 13, 2009	Sheet	24 of 53

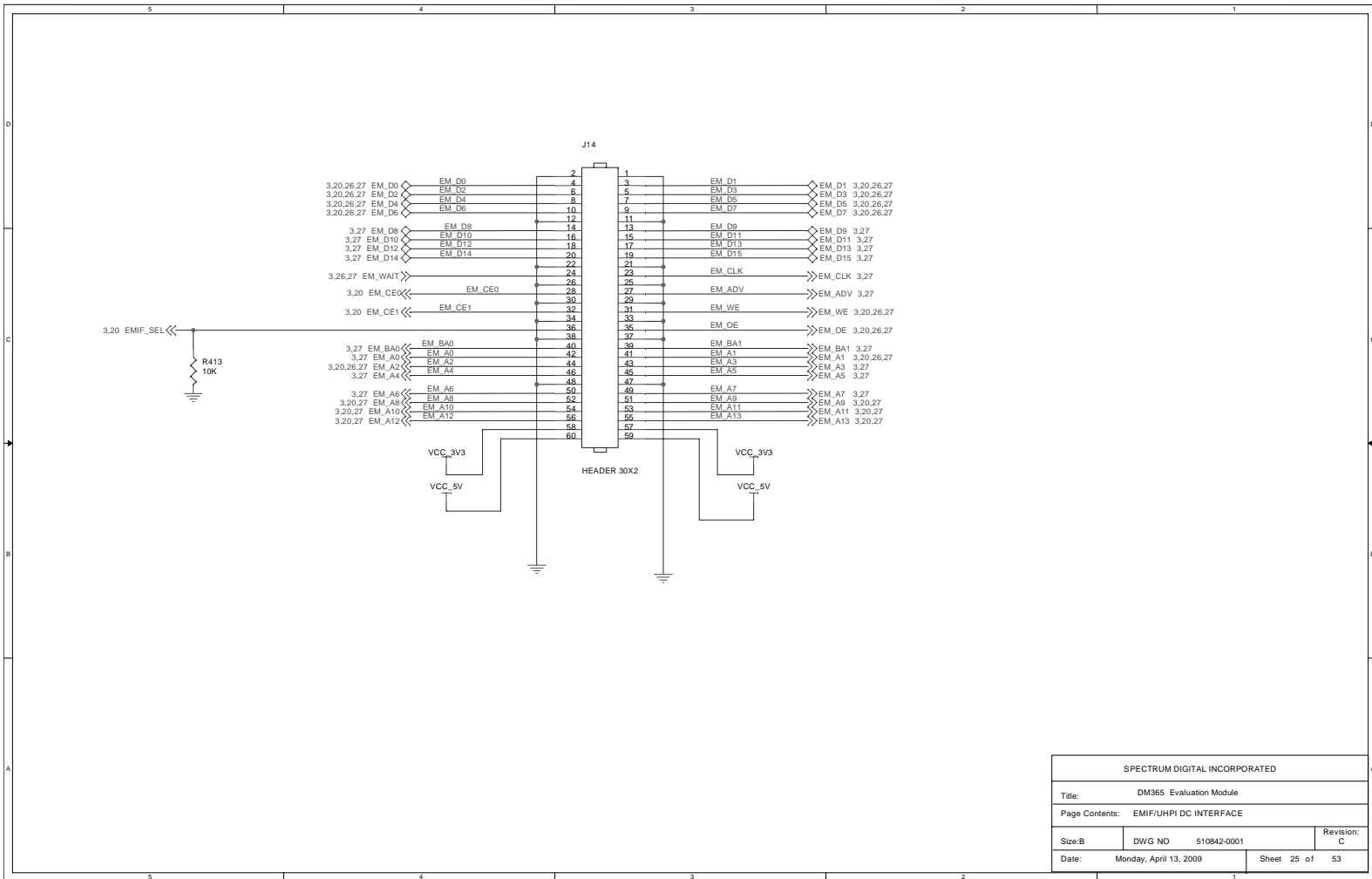

SPECTRUM DIGITAL INCORPORATED		
Title: DM365 Evaluation Module		
Page Contents: EMIF/UHPI DC INTERFACE		
Size: B	DWG NO 510842-0001	Revision: C
Date: Monday, April 13, 2009	Sheet 25 of	53

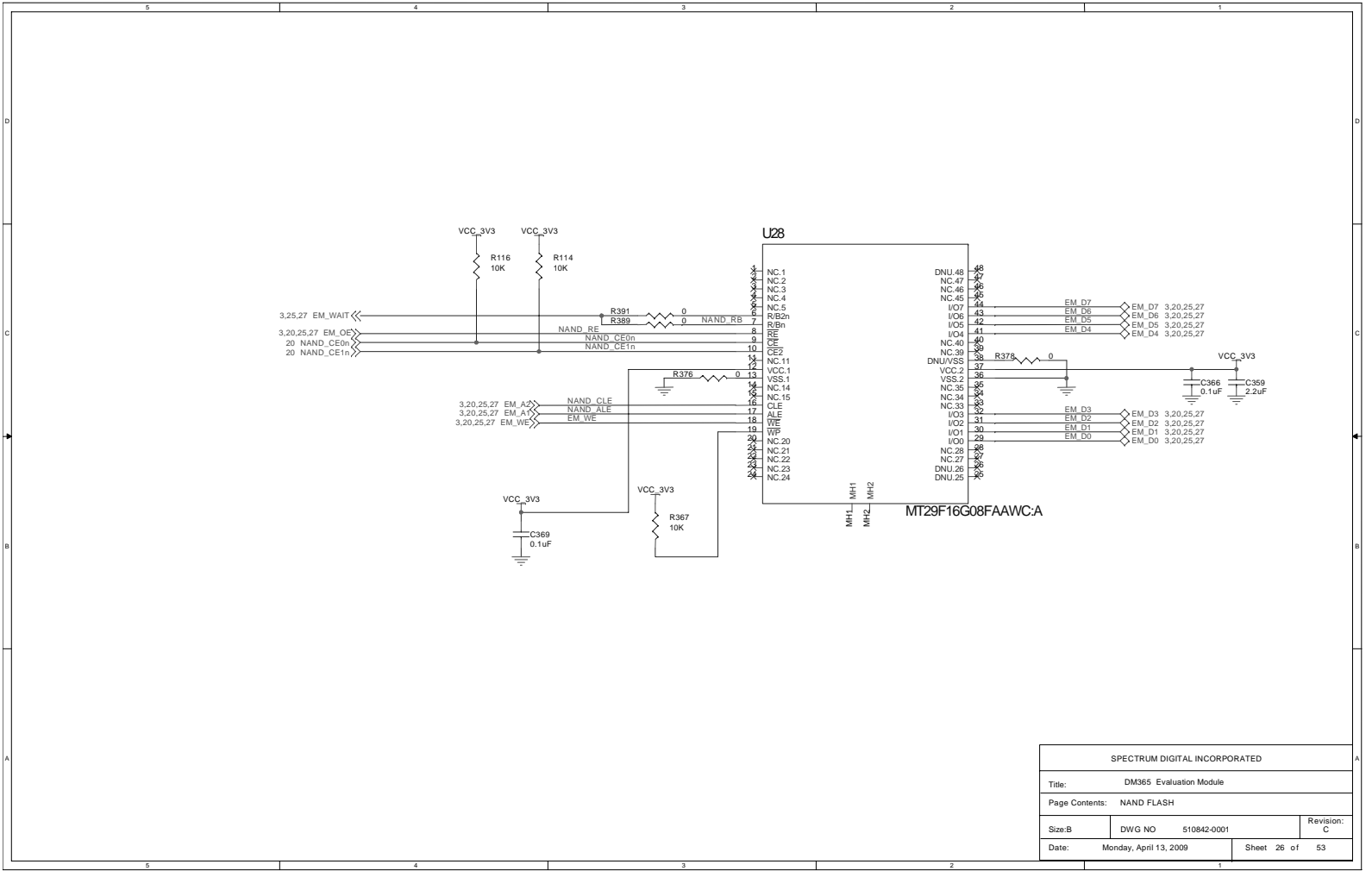

Spectrum Digital, Inc

SPECTRUM DIGITAL INCORPORATED		
Title: DM365 Evaluation Module		
Page Contents: NAND FLASH		
Size: B	DWG NO: 510842-0001	Revision: C
Date: Monday, April 13, 2009	Sheet: 26 of 53	

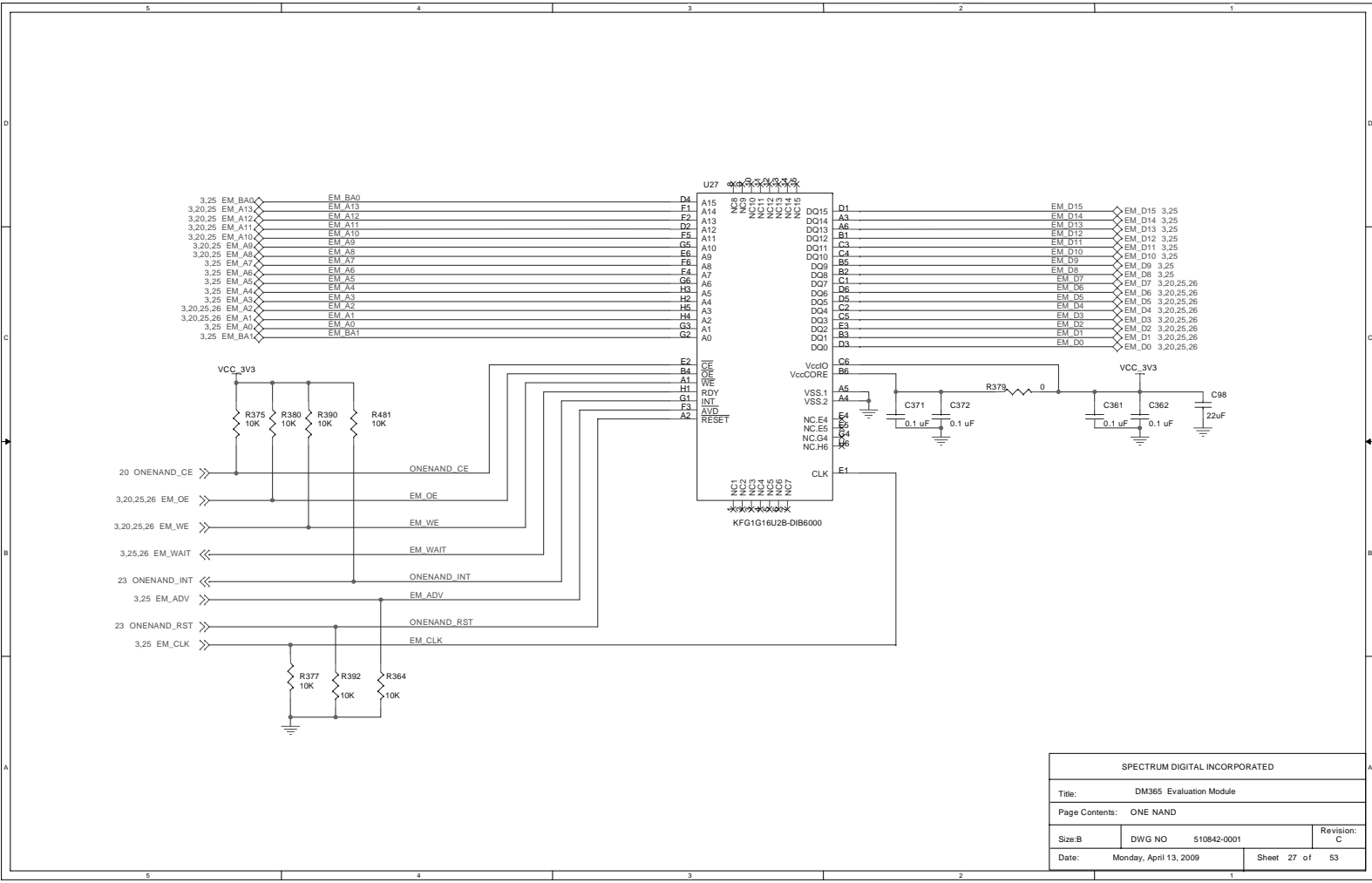

SPECTRUM DIGITAL INCORPORATED		
Title: DM365 Evaluation Module		
Page Contents: ONE NAND		
Size: B	DWG NO: 510842-0001	Revision: C
Date: Monday, April 13, 2009	Sheet 27 of 53	

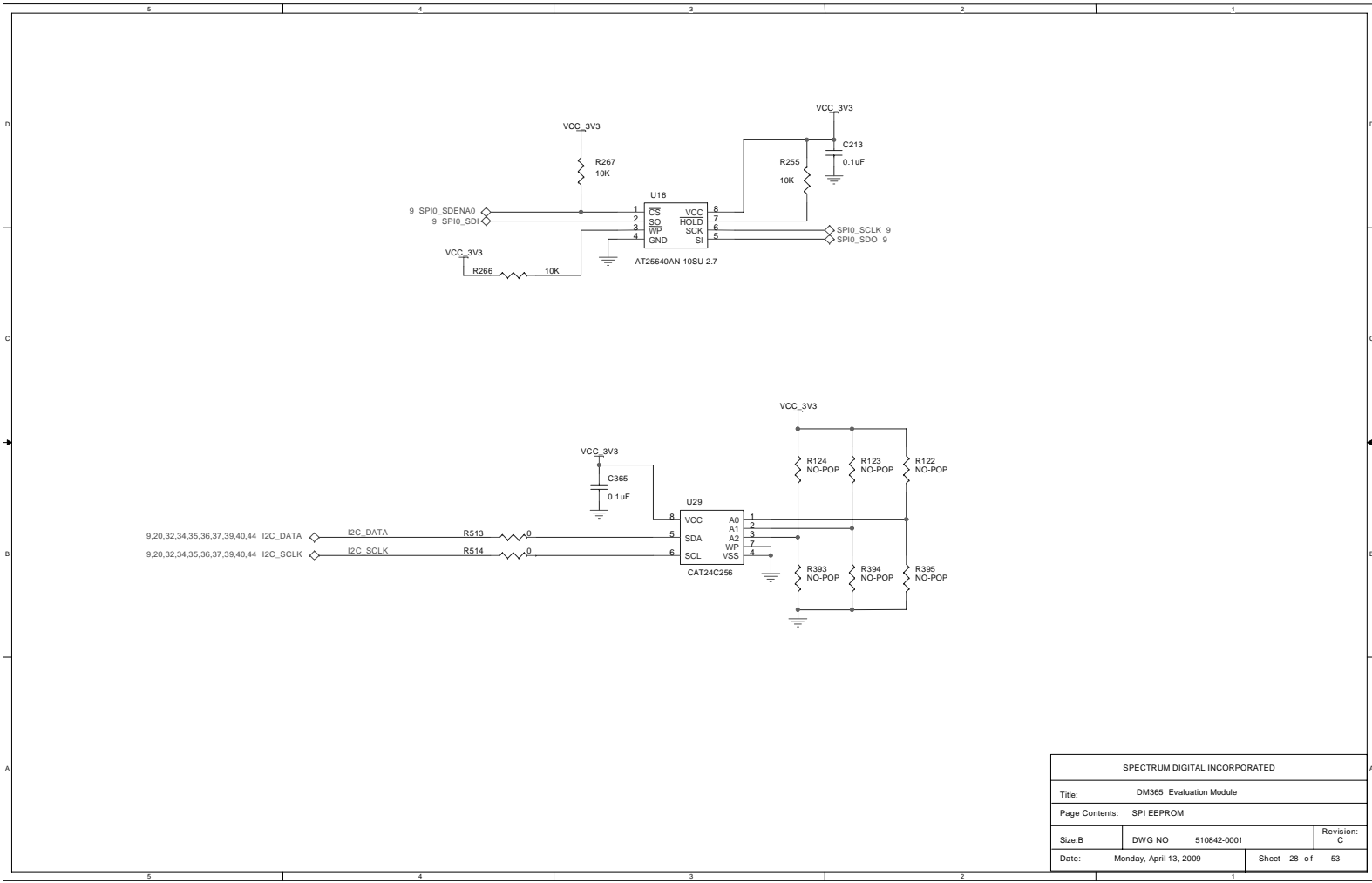

SPECTRUM DIGITAL INCORPORATED			
Title: DM365 Evaluation Module			
Page Contents: SPI EEPROM			
Size: B	DWG NO: 510842-0001	Revision: C	
Date: Monday, April 13, 2009	Sheet 28 of 53		

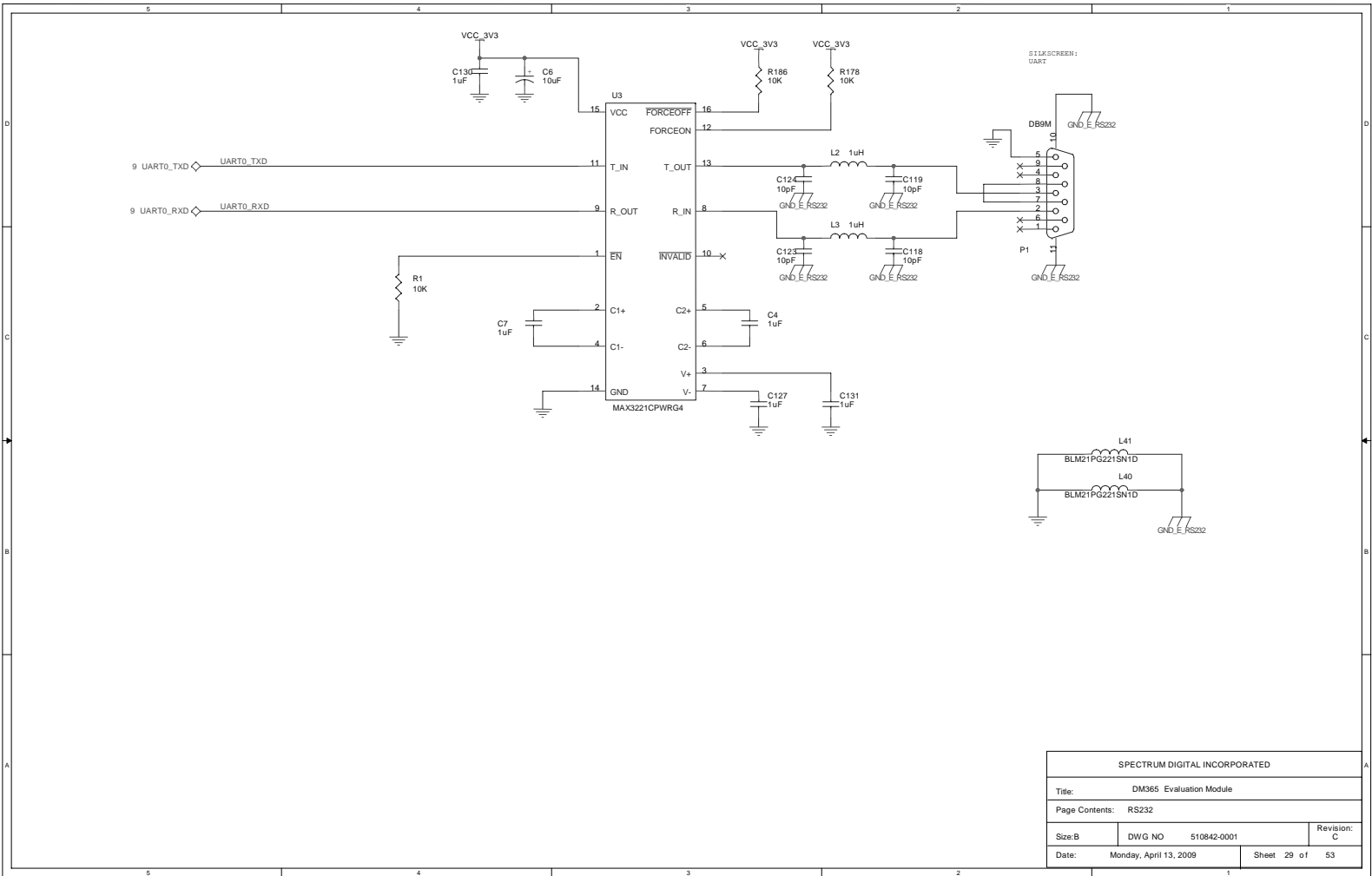

SPECTRUM DIGITAL INCORPORATED		
Title: DM365 Evaluation Module		
Page Contents: RS232		
Size: B	DWG NO 510842-0001	Revision: C
Date: Monday, April 13, 2009	Sheet 29 of 53	

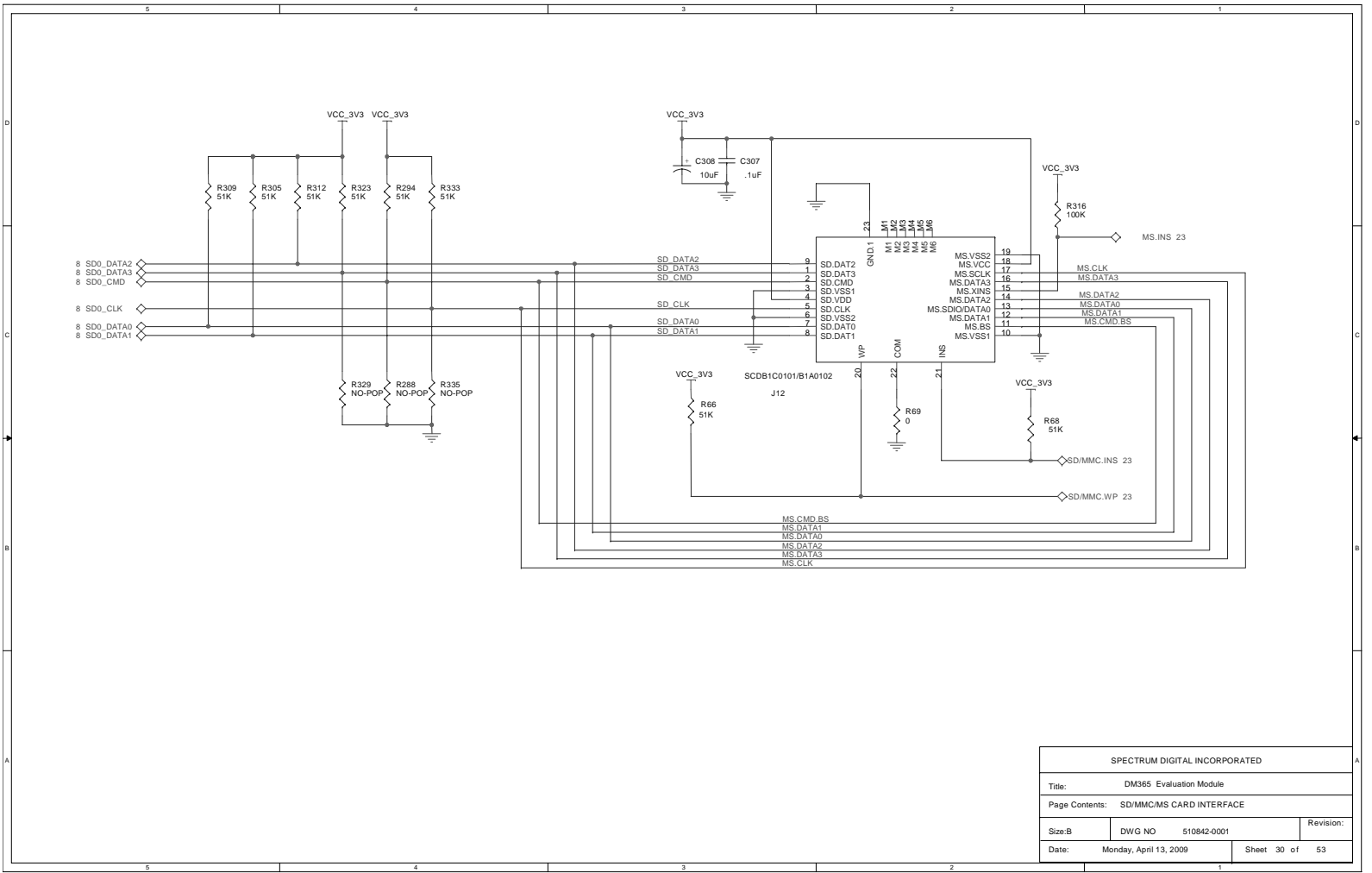

SPECTRUM DIGITAL INCORPORATED			
Title: DM365 Evaluation Module			
Page Contents: SD/MMC CARD INTERFACE			
Size: B	DWG NO	510842-0001	Revision:
Date:	Monday, April 13, 2009	Sheet	30 of 53

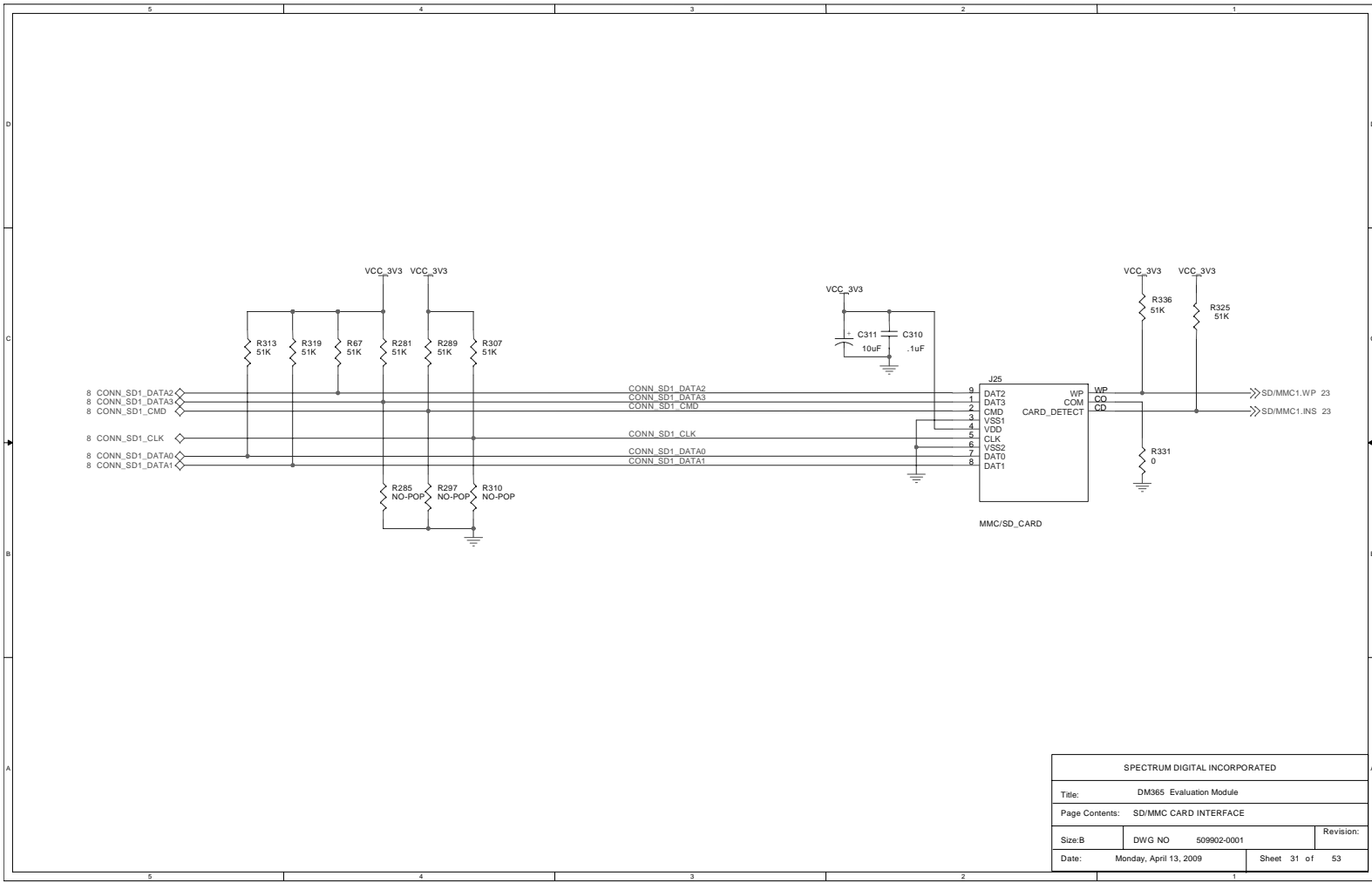

SPECTRUM DIGITAL INCORPORATED		
Title: DM365 Evaluation Module		
Page Contents: SD/MMC CARD INTERFACE		
Size: B	DWG NO: 509902-0001	Revision:
Date: Monday, April 13, 2009	Sheet 31 of 53	

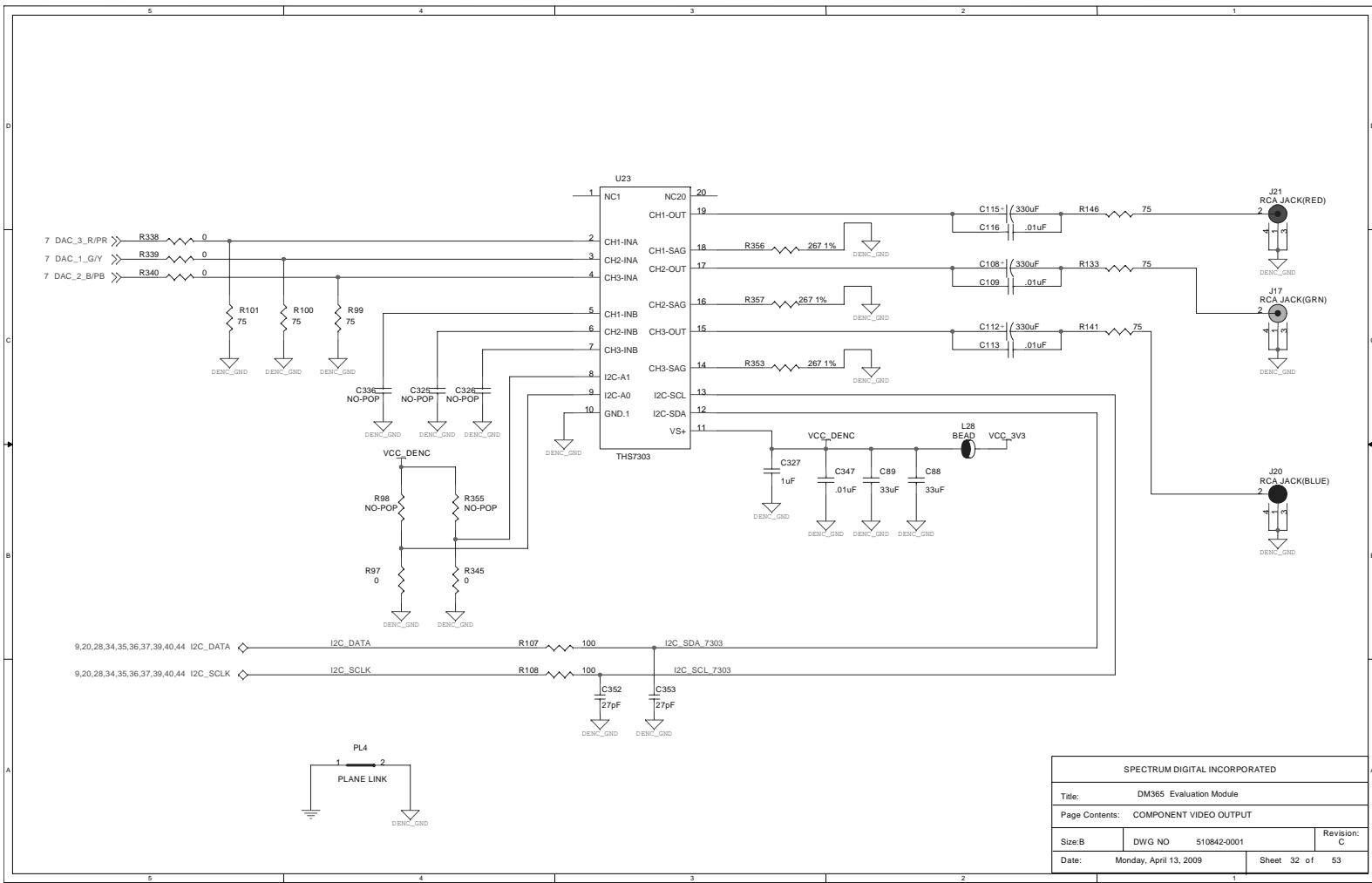

SPECTRUM DIGITAL INCORPORATED			
Title: DM365 Evaluation Module			
Page Contents: COMPONENT VIDEO OUTPUT			
Size: B	DWG NO	510842-001	Revision: C
Date: Monday, April 13, 2009	Sheet 32 of 53		

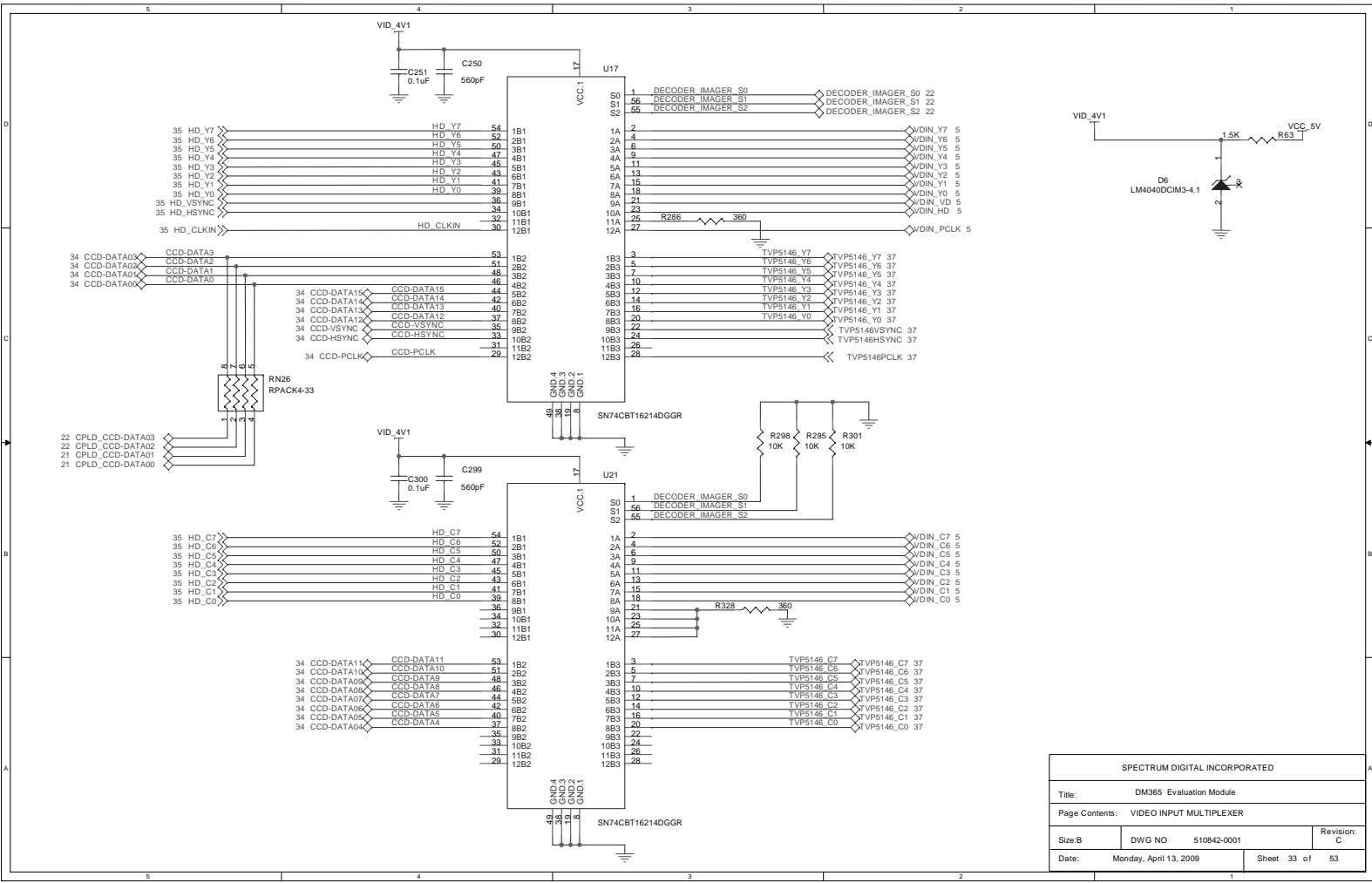

SPECTRUM DIGITAL INCORPORATED		
Title: DM365 Evaluation Module		
Page Contents: VIDEO INPUT MULTIPLEXER		
Size: B	DWG NO 510842-0001	Revision: C
Date: Monday, April 13, 2009	Sheet 33 of 53	

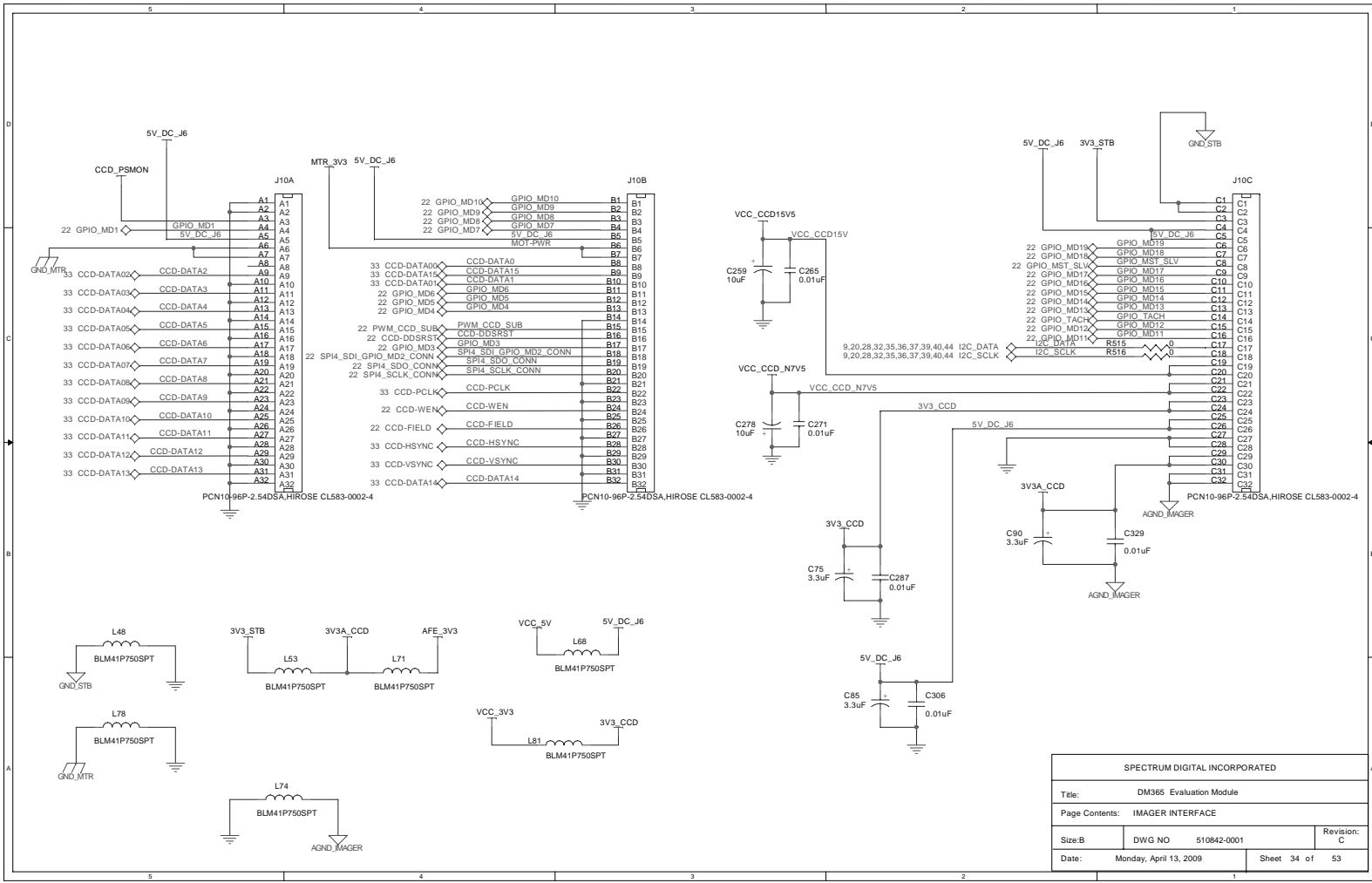

SPECTRUM DIGITAL INCORPORATED			
Title: DM365 Evaluation Module			
Page Contents: IMAGER INTERFACE			
Size: B	DWG NO	510842-0001	Revision: C
Date: Monday, April 13, 2009	Sheet 34 of 53		

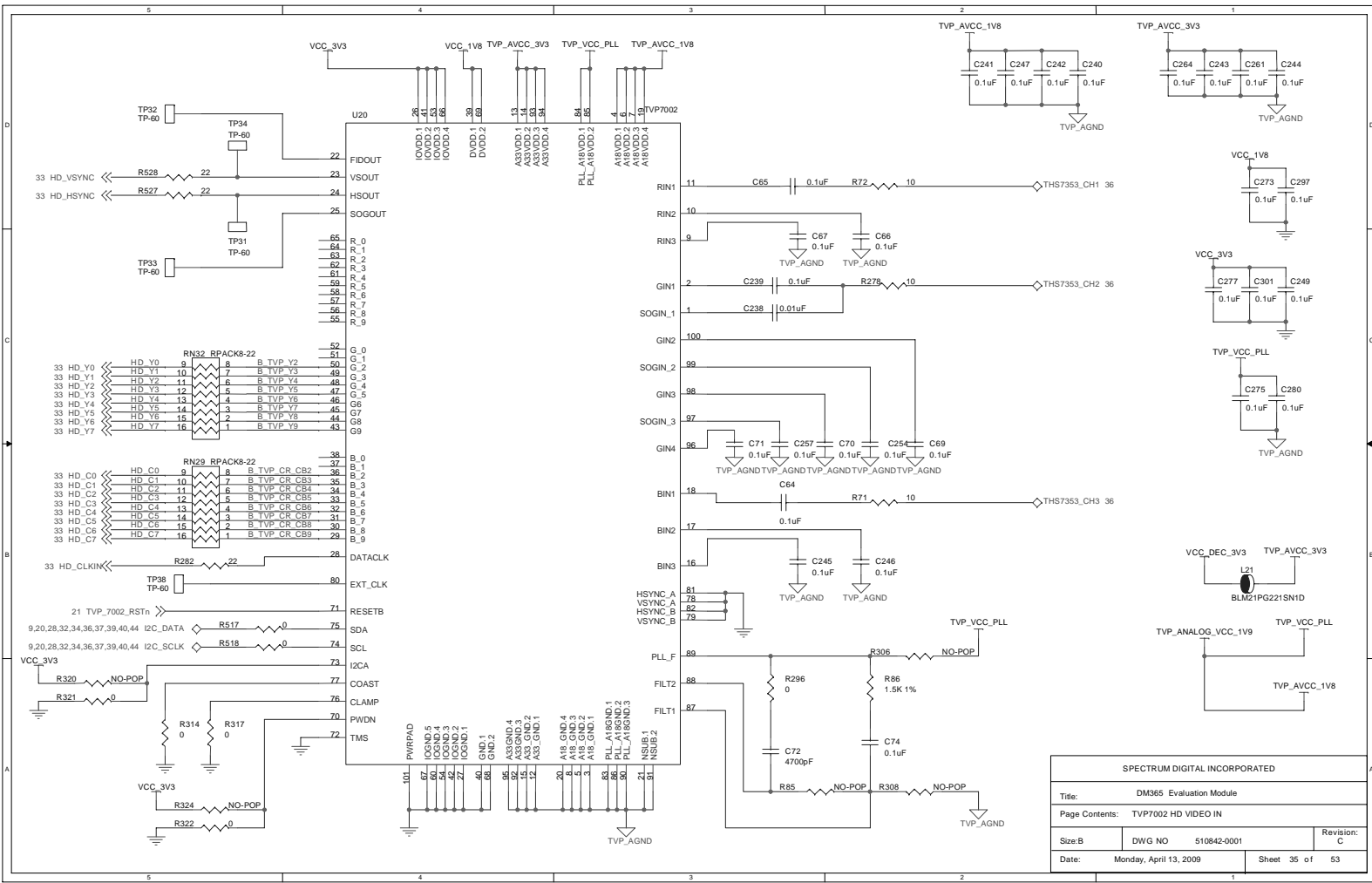

SPECTRUM DIGITAL INCORPORATED		
Title: DM365 Evaluation Module		
Page Contents: TVP7002 HD VIDEO IN		
Size: B	DWG NO: 510842-0001	Revision: C
Date: Monday, April 13, 2009	Sheet 35 of 53	

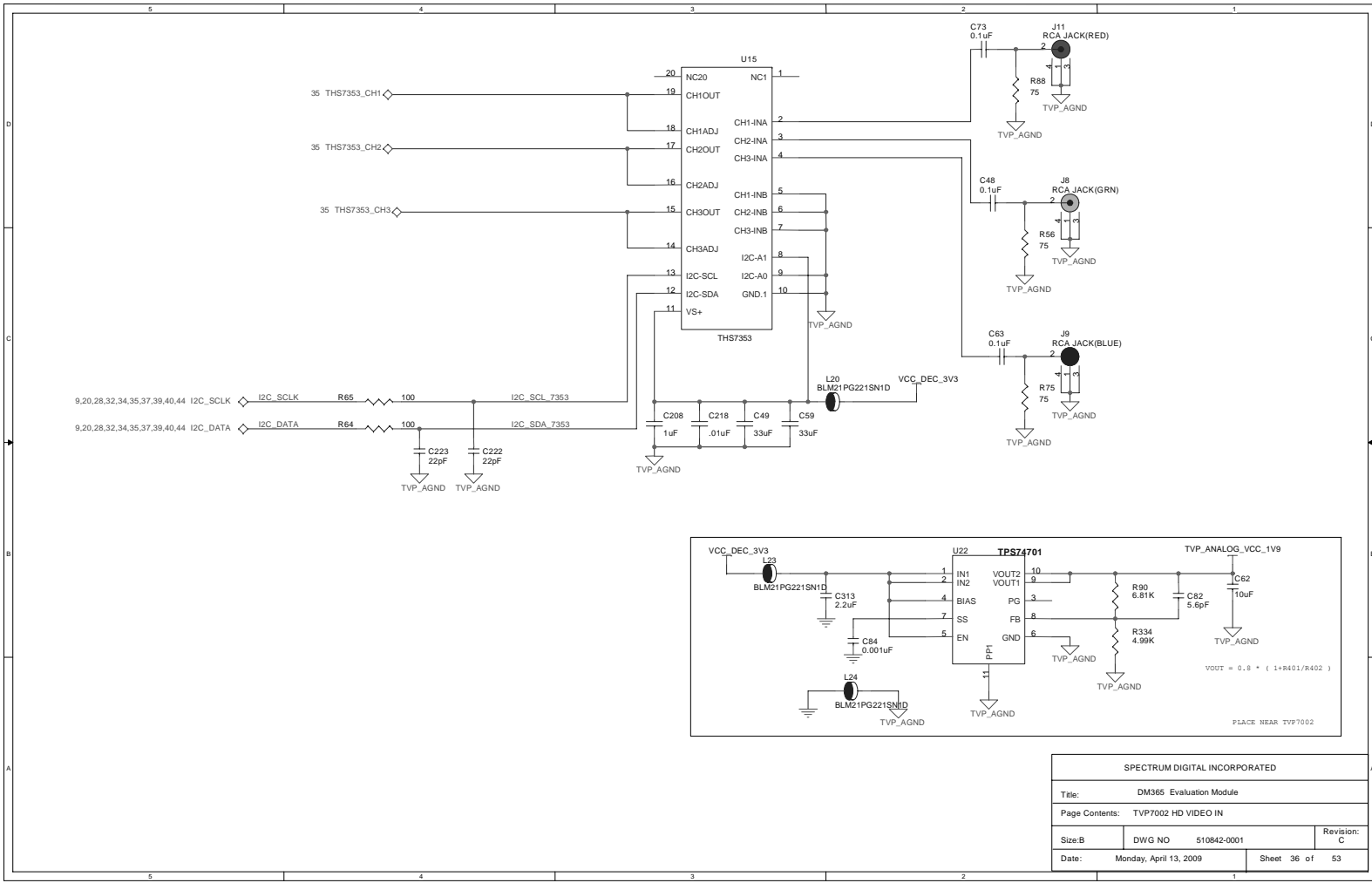

SPECTRUM DIGITAL INCORPORATED			
Title: DM365 Evaluation Module			
Page Contents: TVP7002 HD VIDEO IN			
Size: B	DWG NO	510842-0001	Revision: C
Date: Monday, April 13, 2009	Sheet 36 of 53		

Spectrum Digital, Inc

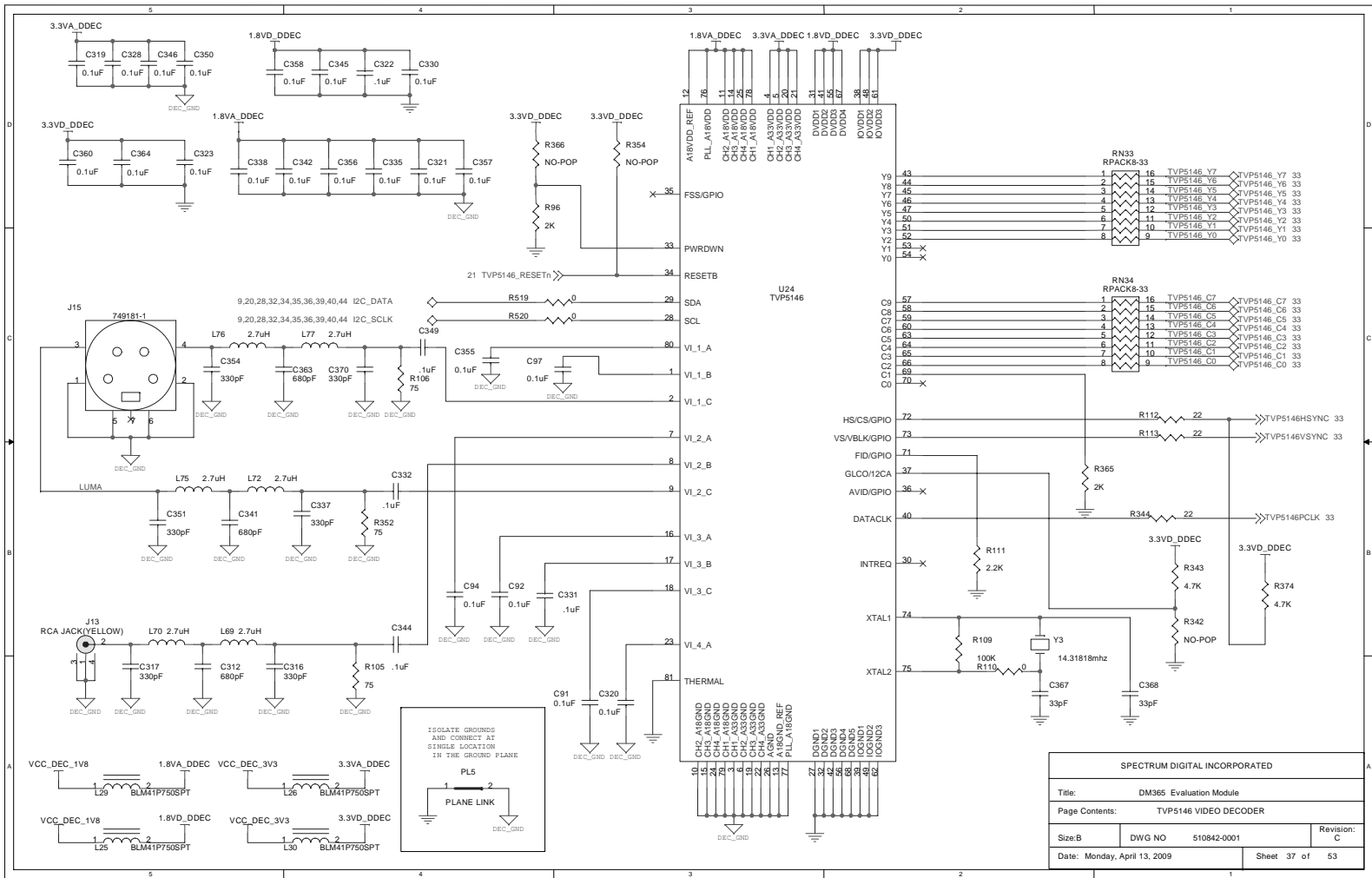

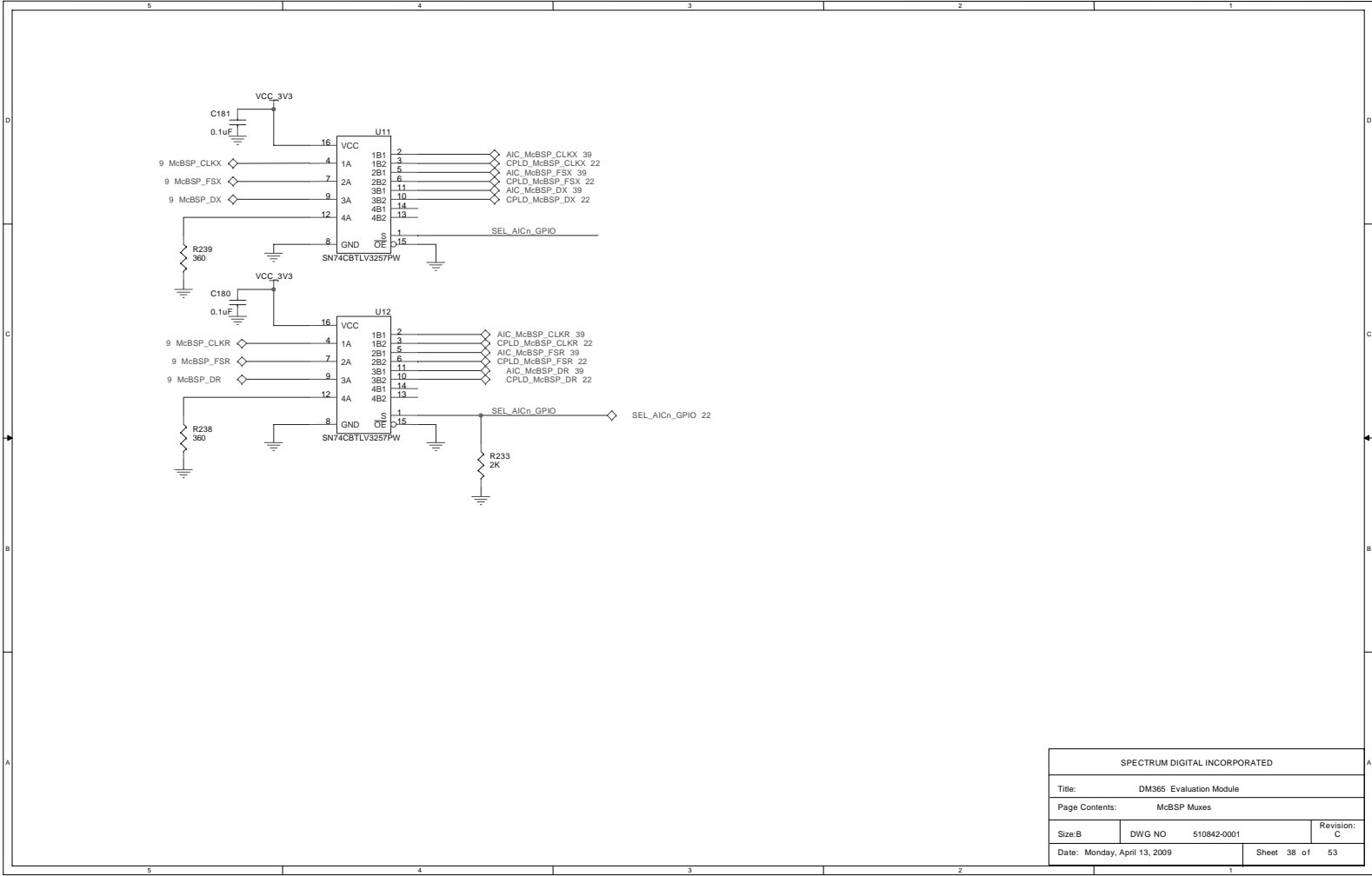

SPECTRUM DIGITAL INCORPORATED			
Title: DM365 Evaluation Module			
Page Contents: McBSP Muxes			
Size: B	DWG NO	510842-0001	Revision: C
Date: Monday, April 13, 2009		Sheet 38 of 53	

Spectrum Digital, Inc

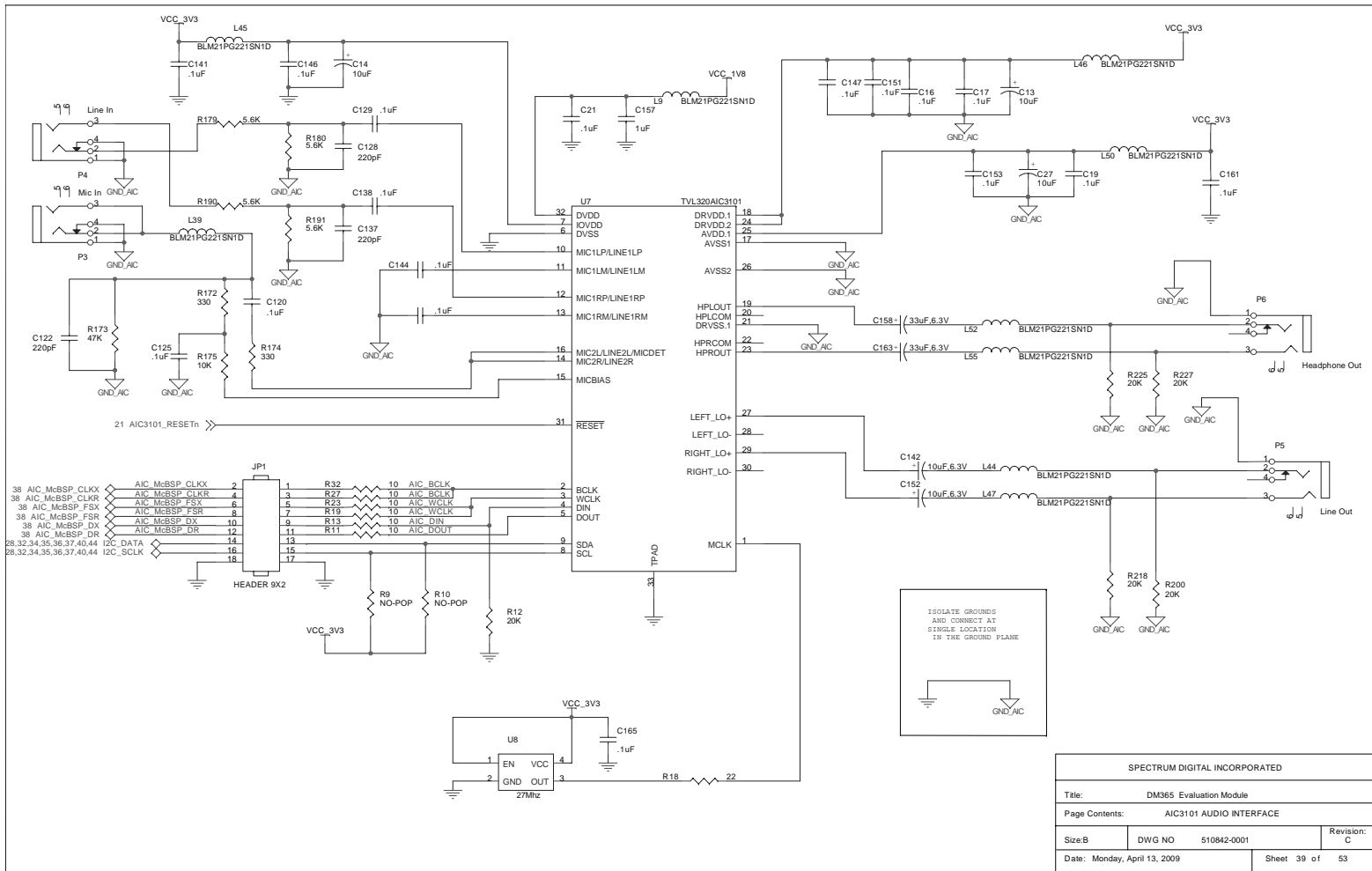

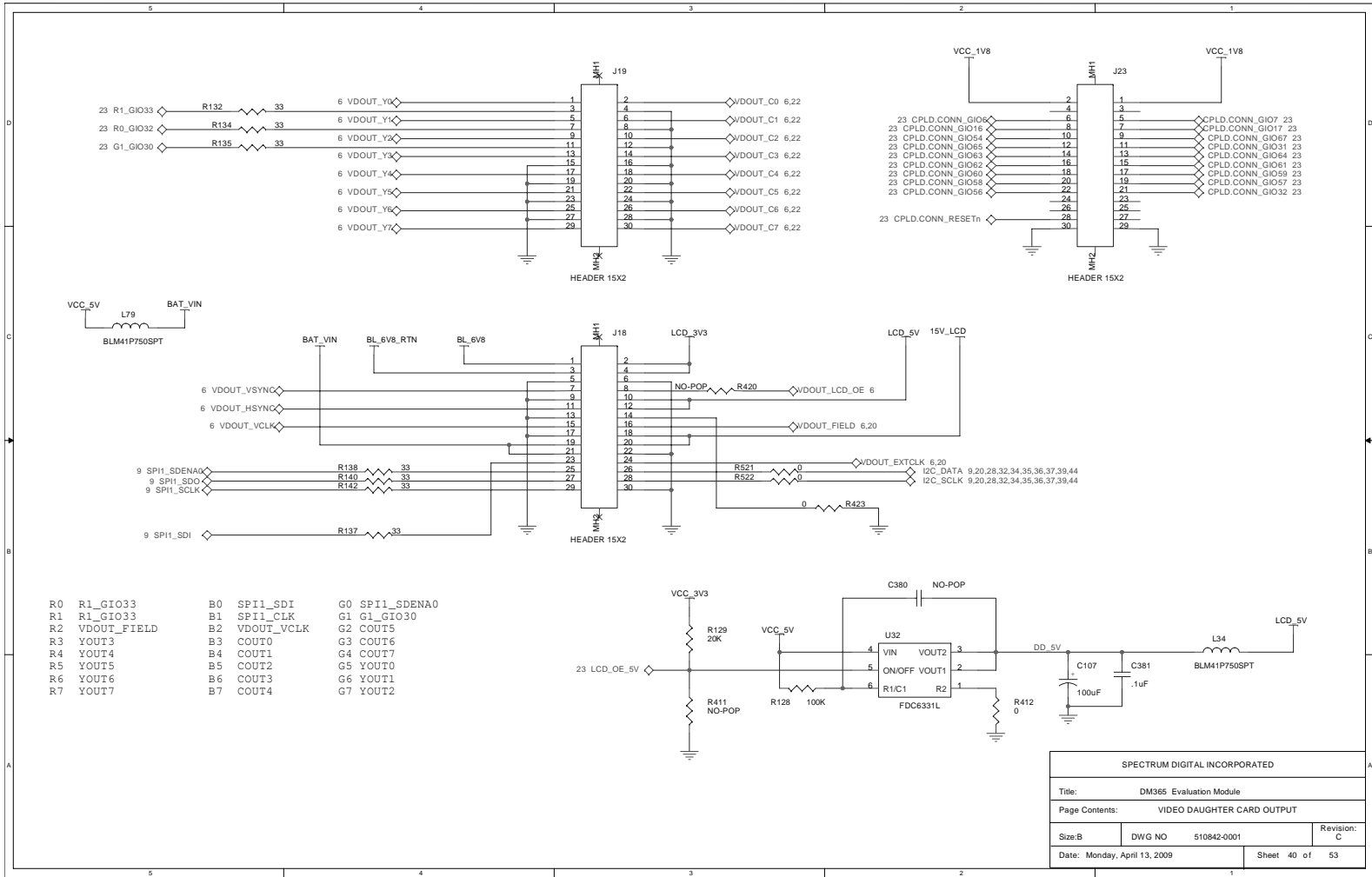

SPECTRUM DIGITAL INCORPORATED			
Title: DM365 Evaluation Module			
Page Contents: VIDEO DAUGHTER CARD OUTPUT			
Size: B	DWG NO	510842-0001	Revision: C
Date: Monday, April 13, 2009		Sheet 40 of 53	

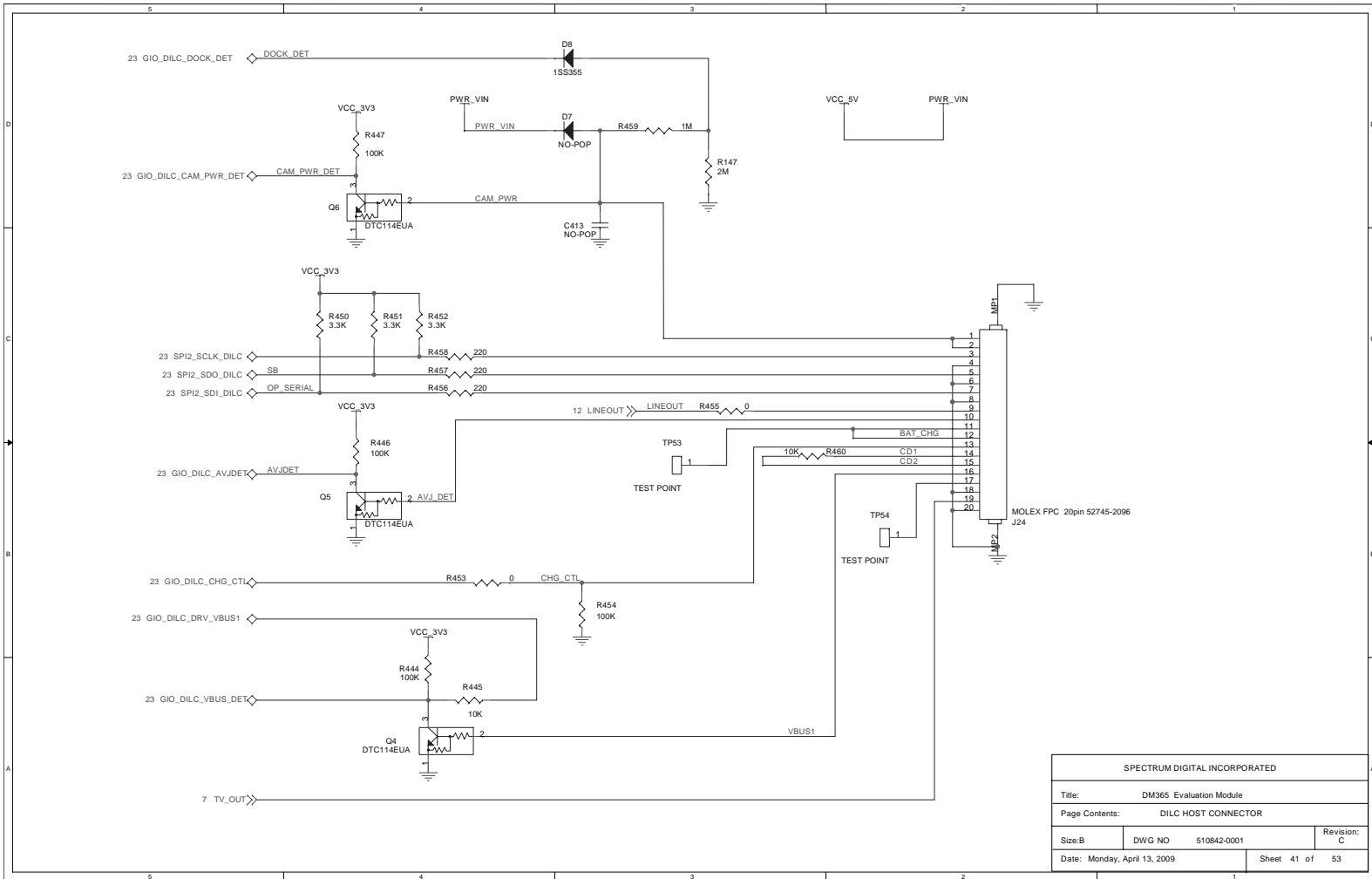

SPECTRUM DIGITAL INCORPORATED			
Title: DM365 Evaluation Module			
Page Contents: DILC HOST CONNECTOR			
Size: B	DWG NO	510842-0001	Revision: C
Date: Monday, April 13, 2009		Sheet 41 of 53	

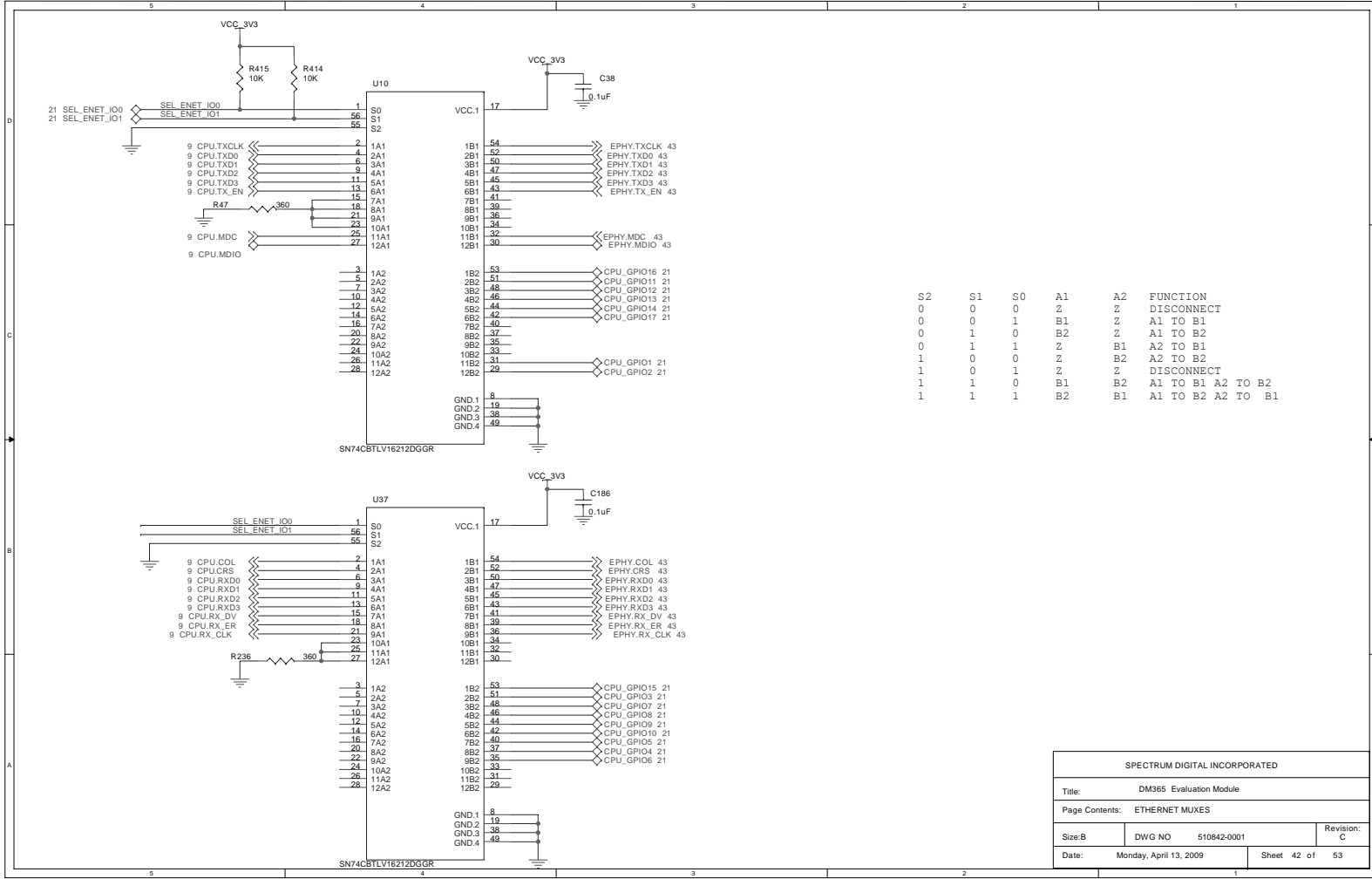

Spectrum Digital, Inc

SPECTRUM DIGITAL INCORPORATED		
Title: DM365 Evaluation Module		
Page Contents: ETHERNET MUXES		
Size: B	DWG NO: 510842-0001	Revision: C
Date: Monday, April 13, 2009	Sheet 42 of 53	

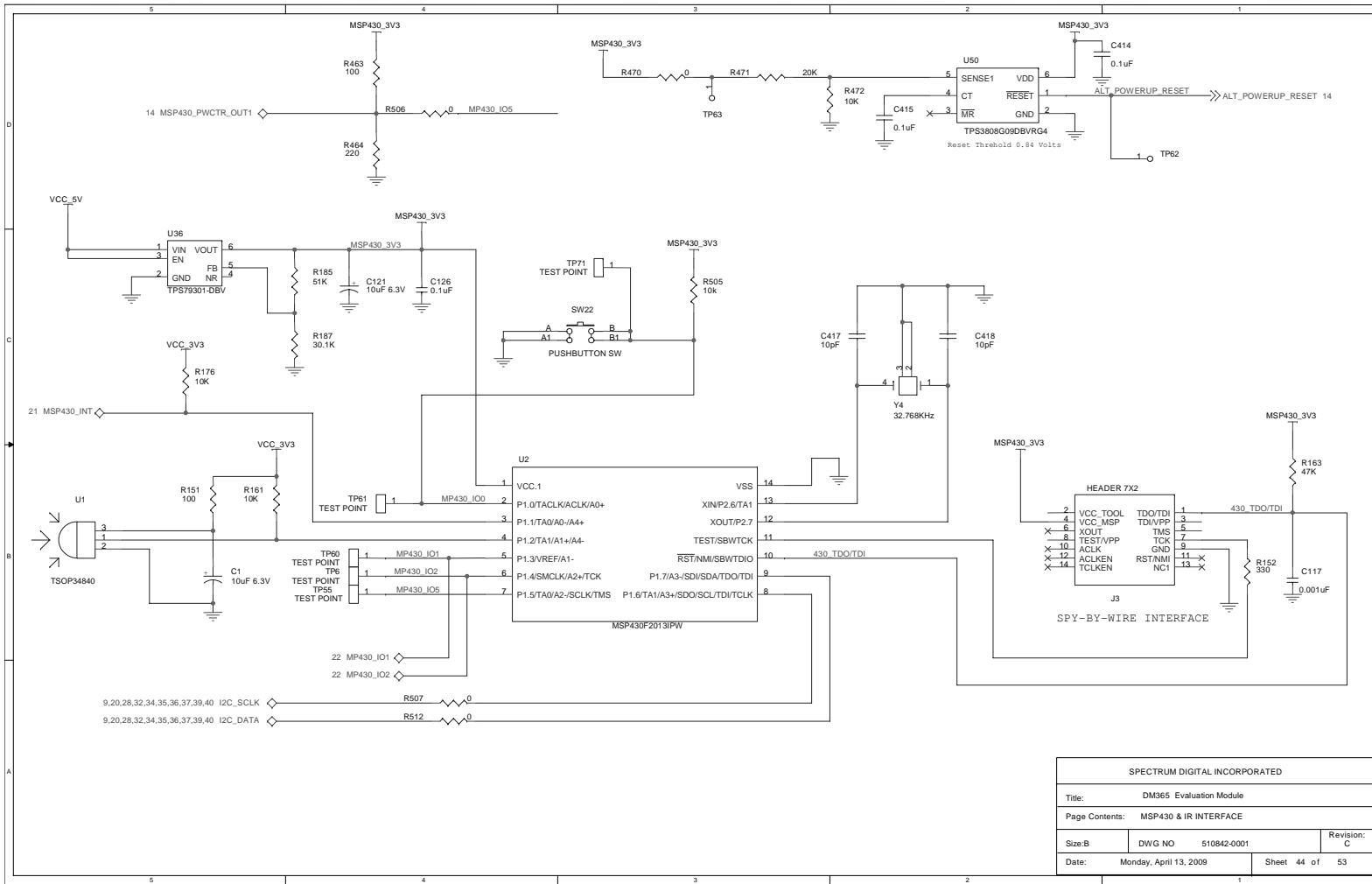

SPECTRUM DIGITAL INCORPORATED			
Title: DM365 Evaluation Module			
Page Contents: MSP430 & IR INTERFACE			
Size: B	DWG NO	510842-0001	Revision: C
Date: Monday, April 13, 2009	Sheet 44 of 53		

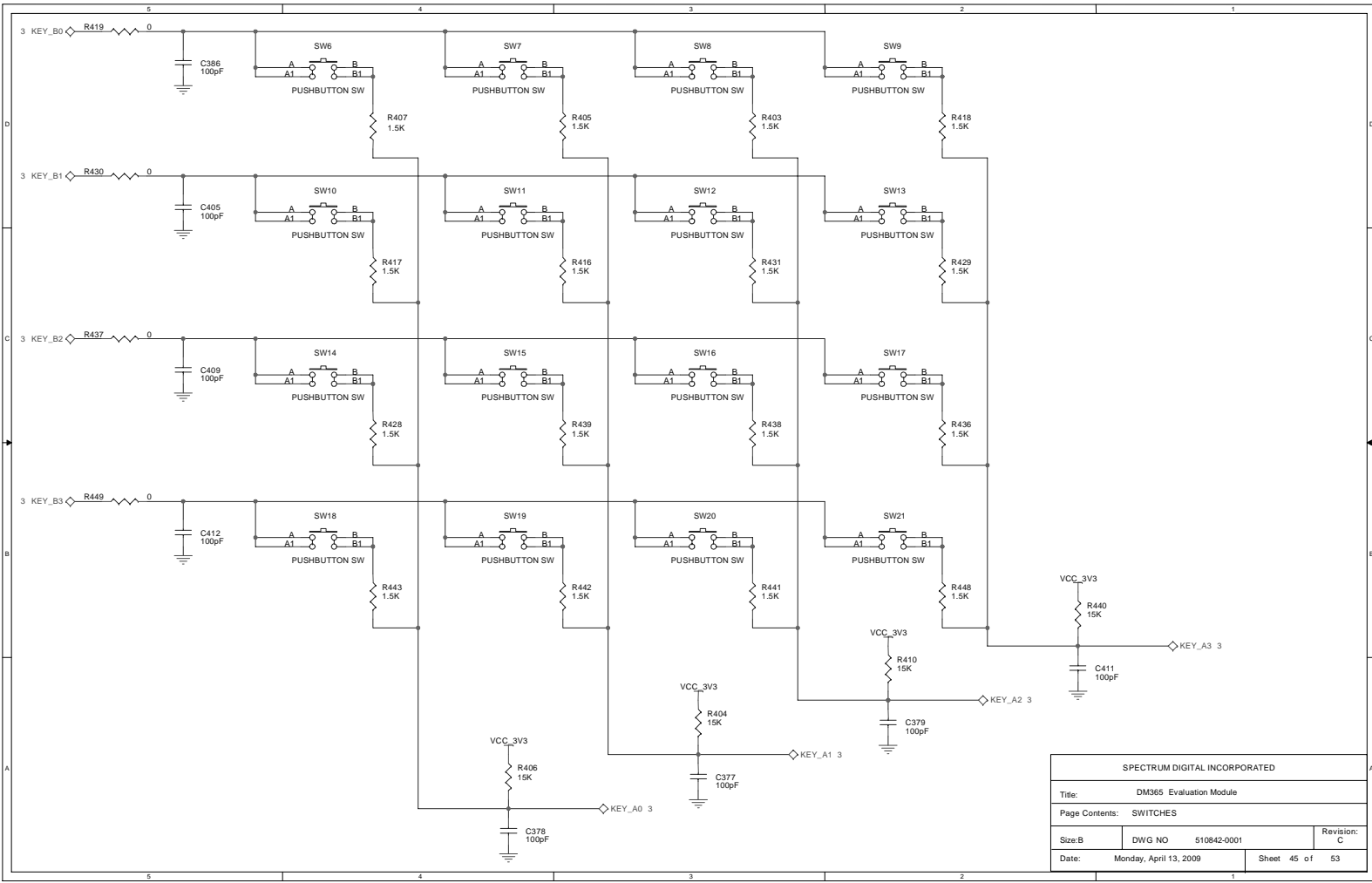

SPECTRUM DIGITAL INCORPORATED		
Title: DM365 Evaluation Module		
Page Contents: SWITCHES		
Size: B	DWG NO: 510842-0001	Revision: C
Date: Monday, April 13, 2009	Sheet 45 of 53	

A-46

DM365 EVM Technical Reference

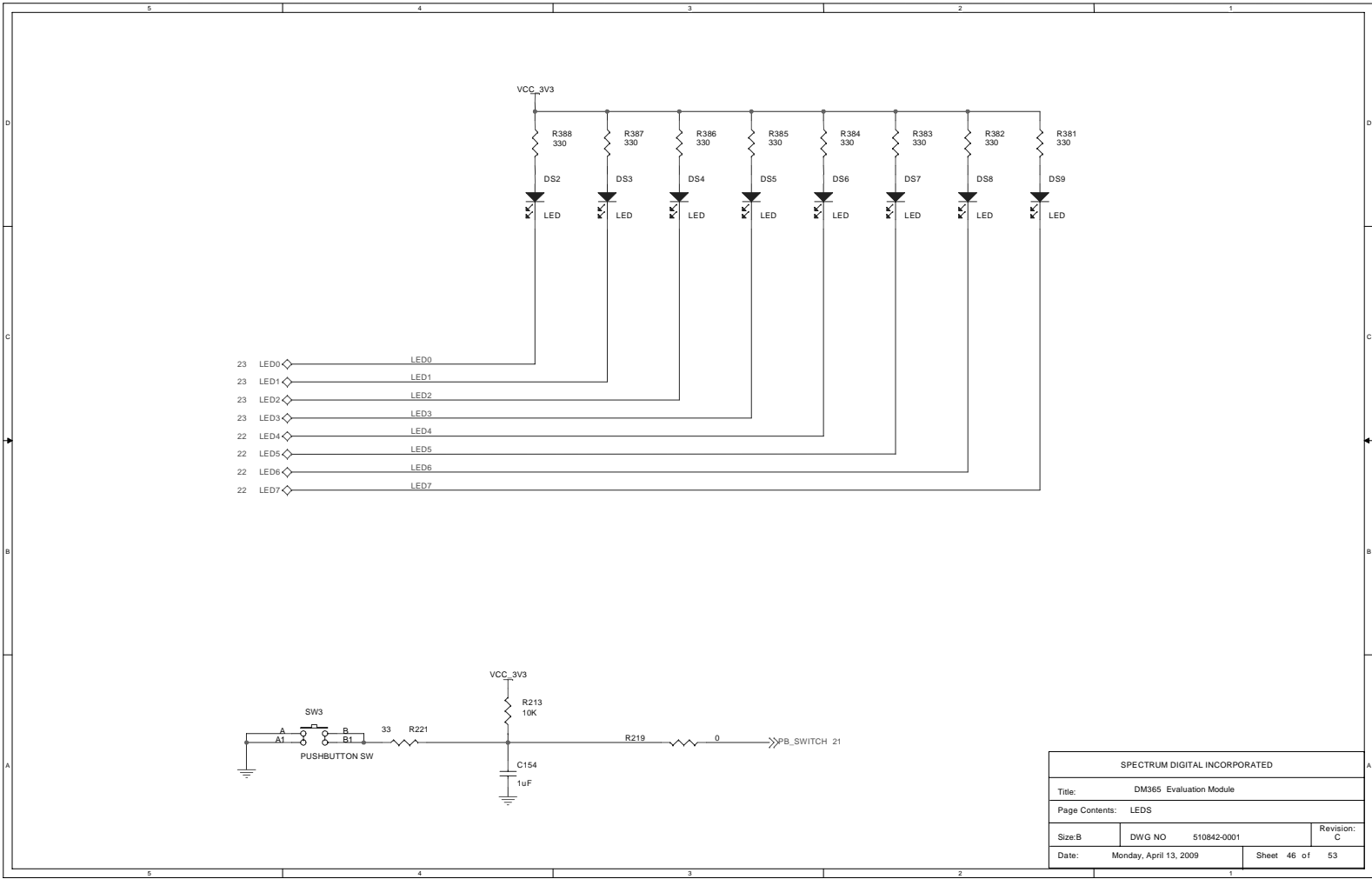

SPECTRUM DIGITAL INCORPORATED		
Title: DM365 Evaluation Module		
Page Contents: LEDES		
Size: B	DWG NO: 510842-0001	Revision: C
Date: Monday, April 13, 2009	Sheet 46 of	53

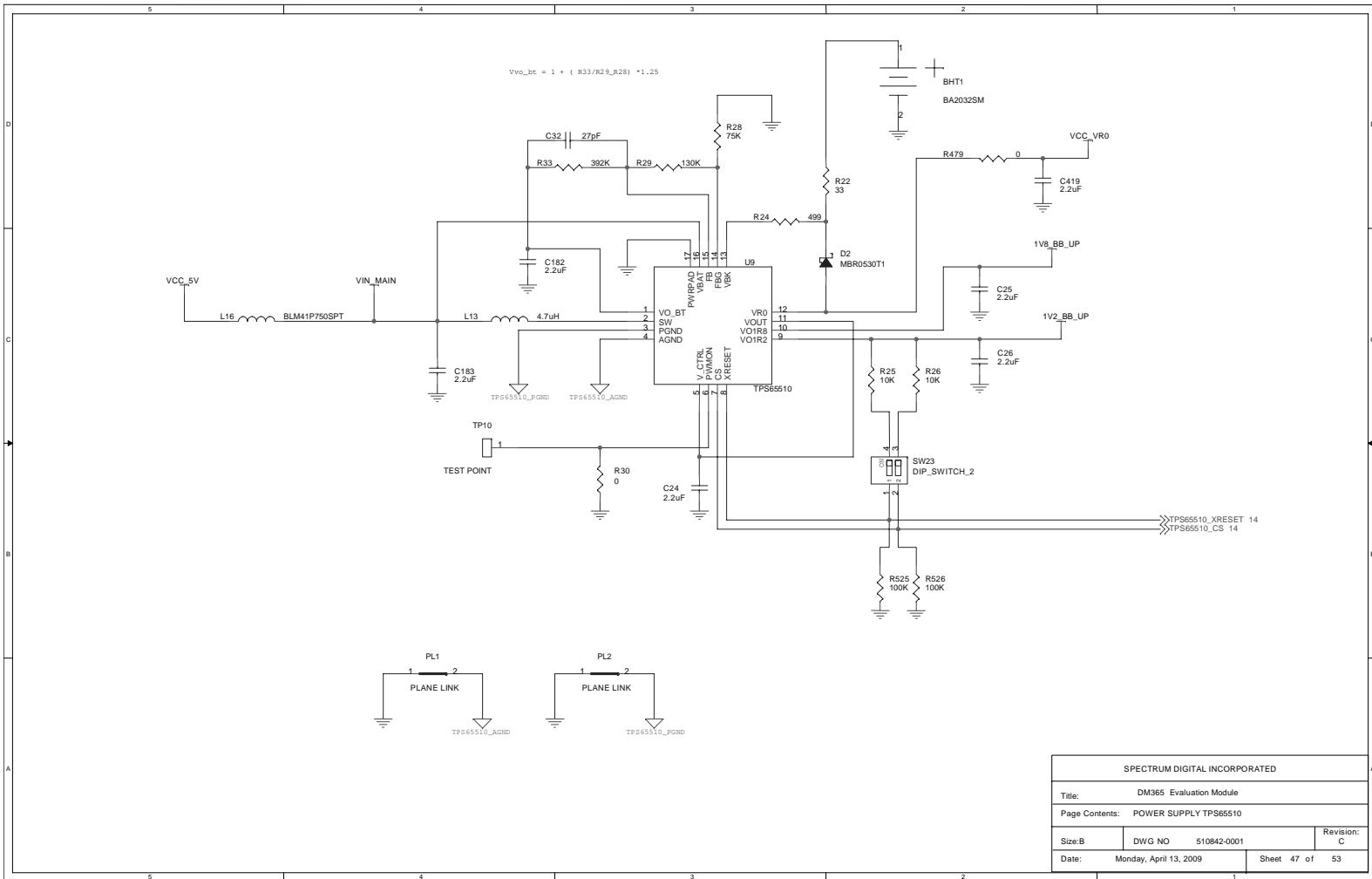

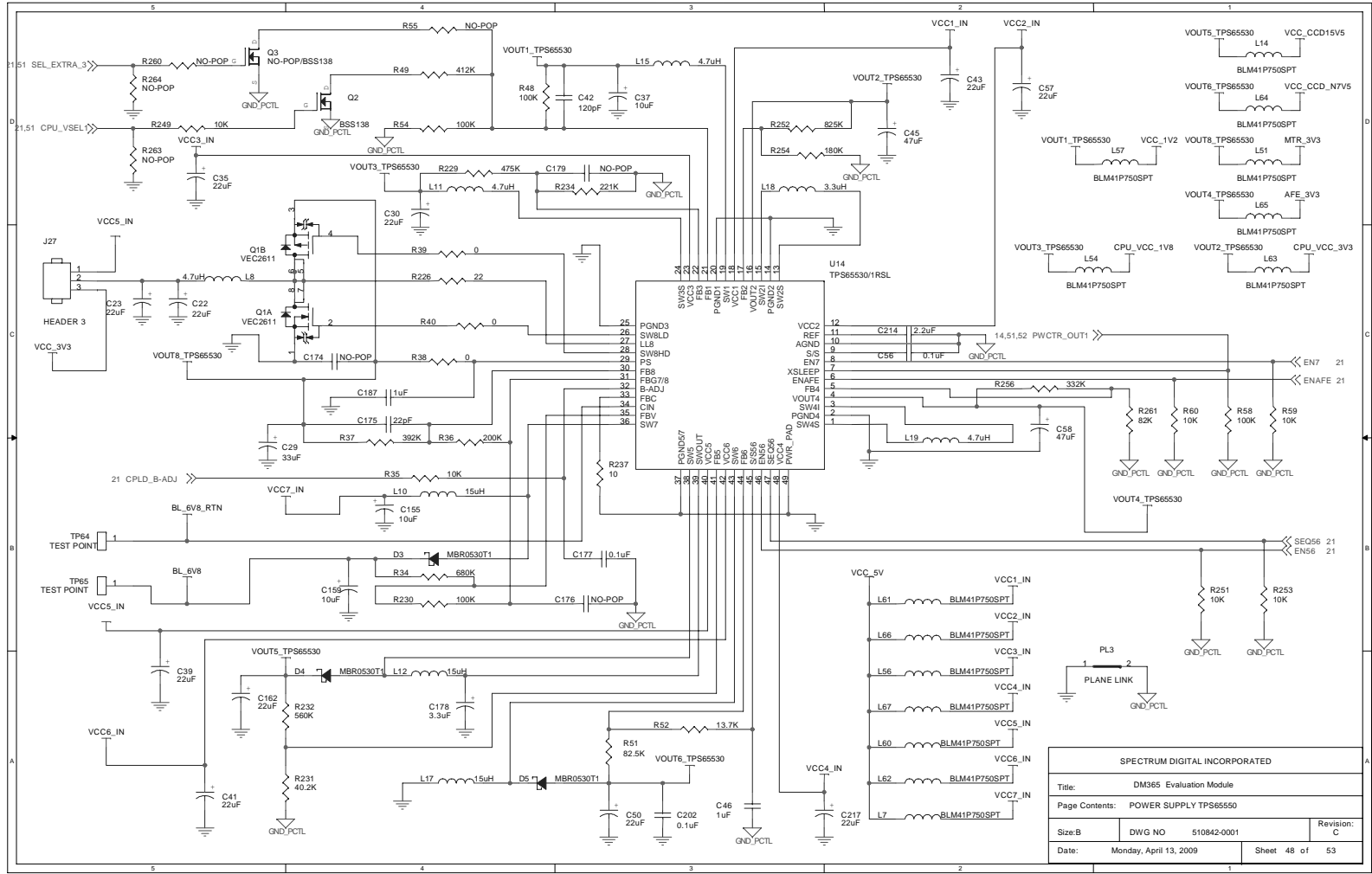

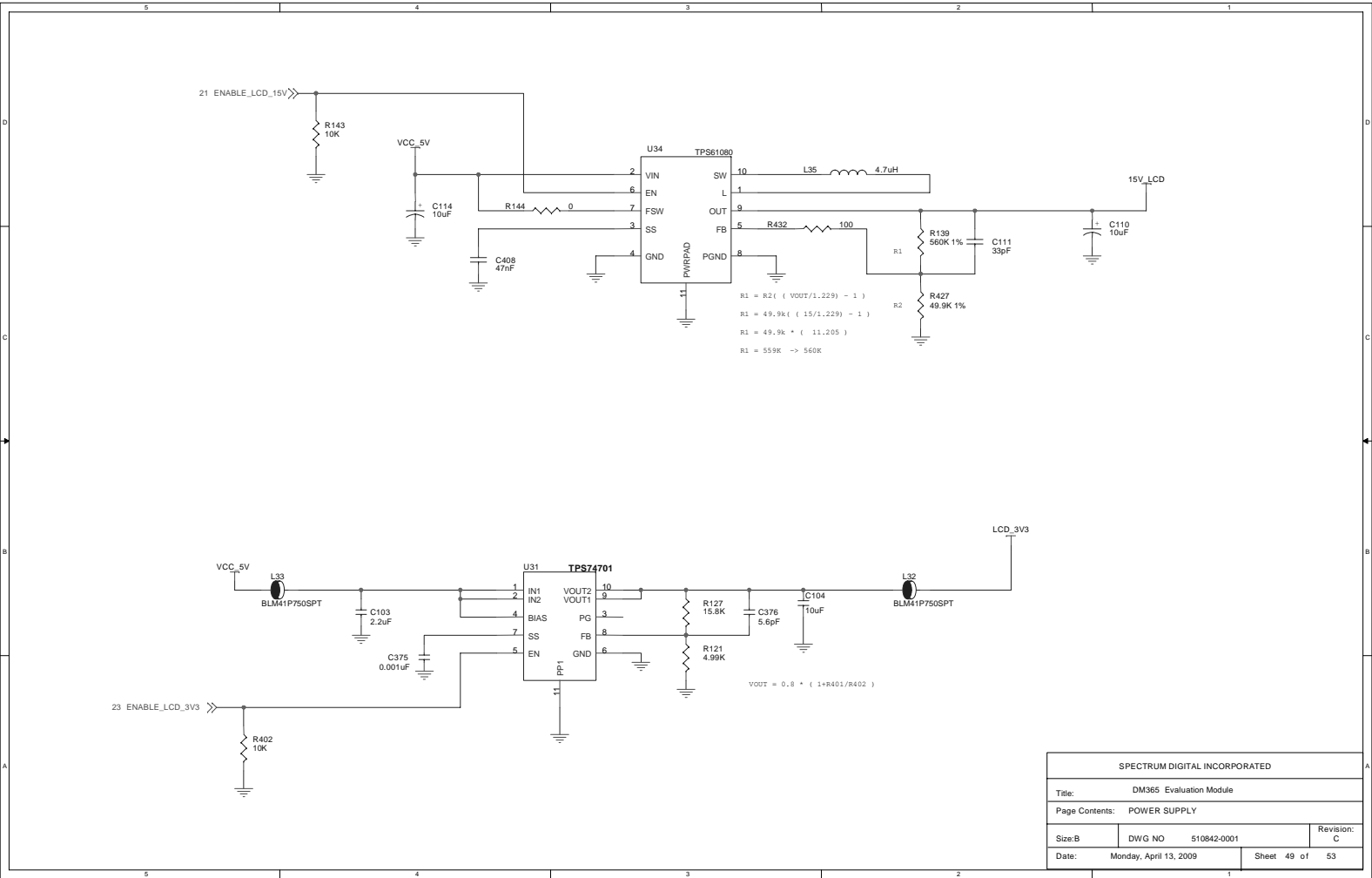

SPECTRUM DIGITAL INCORPORATED		
Title: DM365 Evaluation Module		
Page Contents: POWER SUPPLY		
Size: B	DWG NO 510842-0001	Revision: C
Date: Monday, April 13, 2009	Sheet 49 of 53	

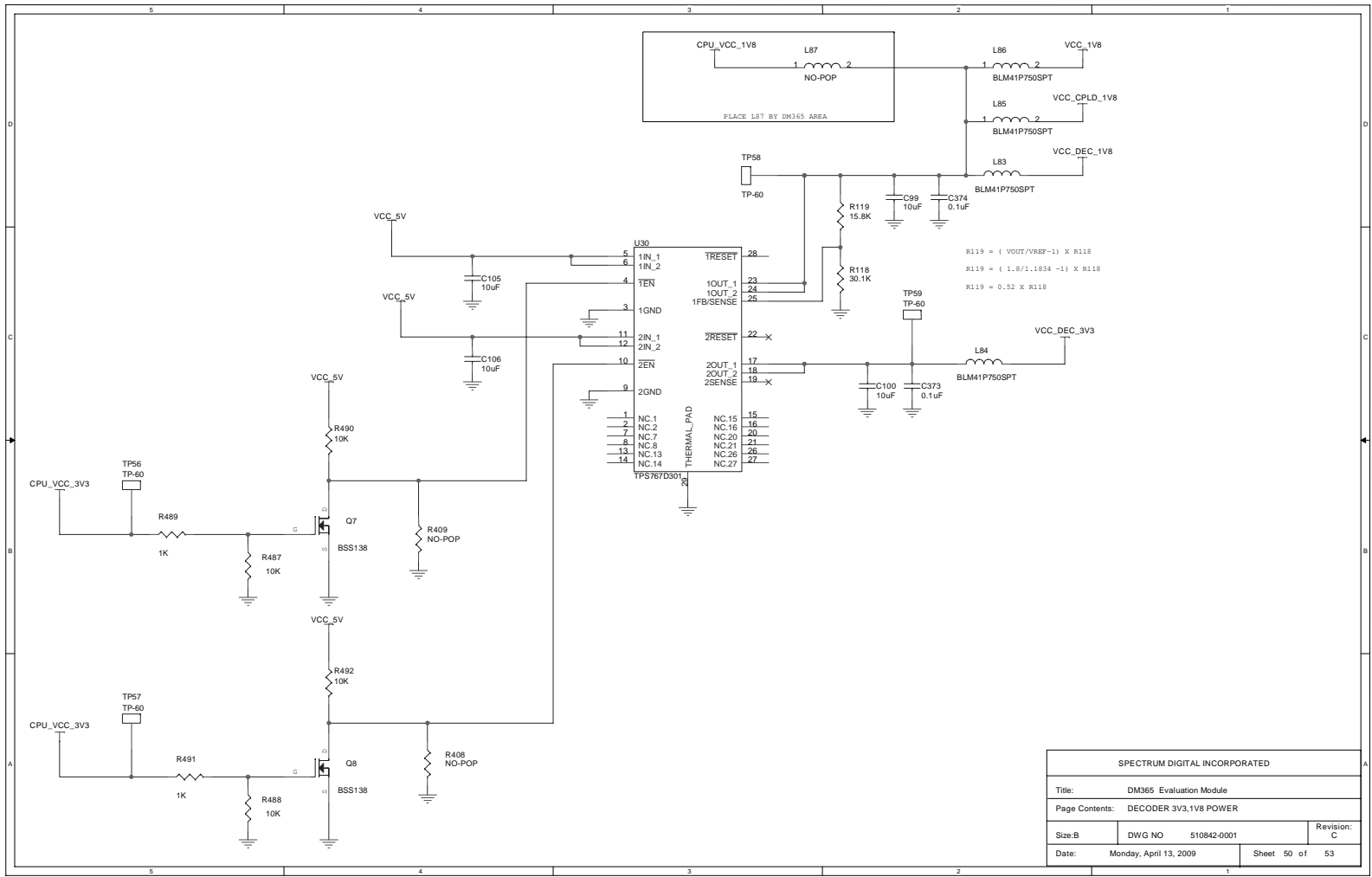

SPECTRUM DIGITAL INCORPORATED			
Title: DM365 Evaluation Module			
Page Contents: DECODER 3V3,1V8 POWER			
Size: B	DWG NO	510842-0001	Revision: C
Date: Monday, April 13, 2009	Sheet	50 of	53

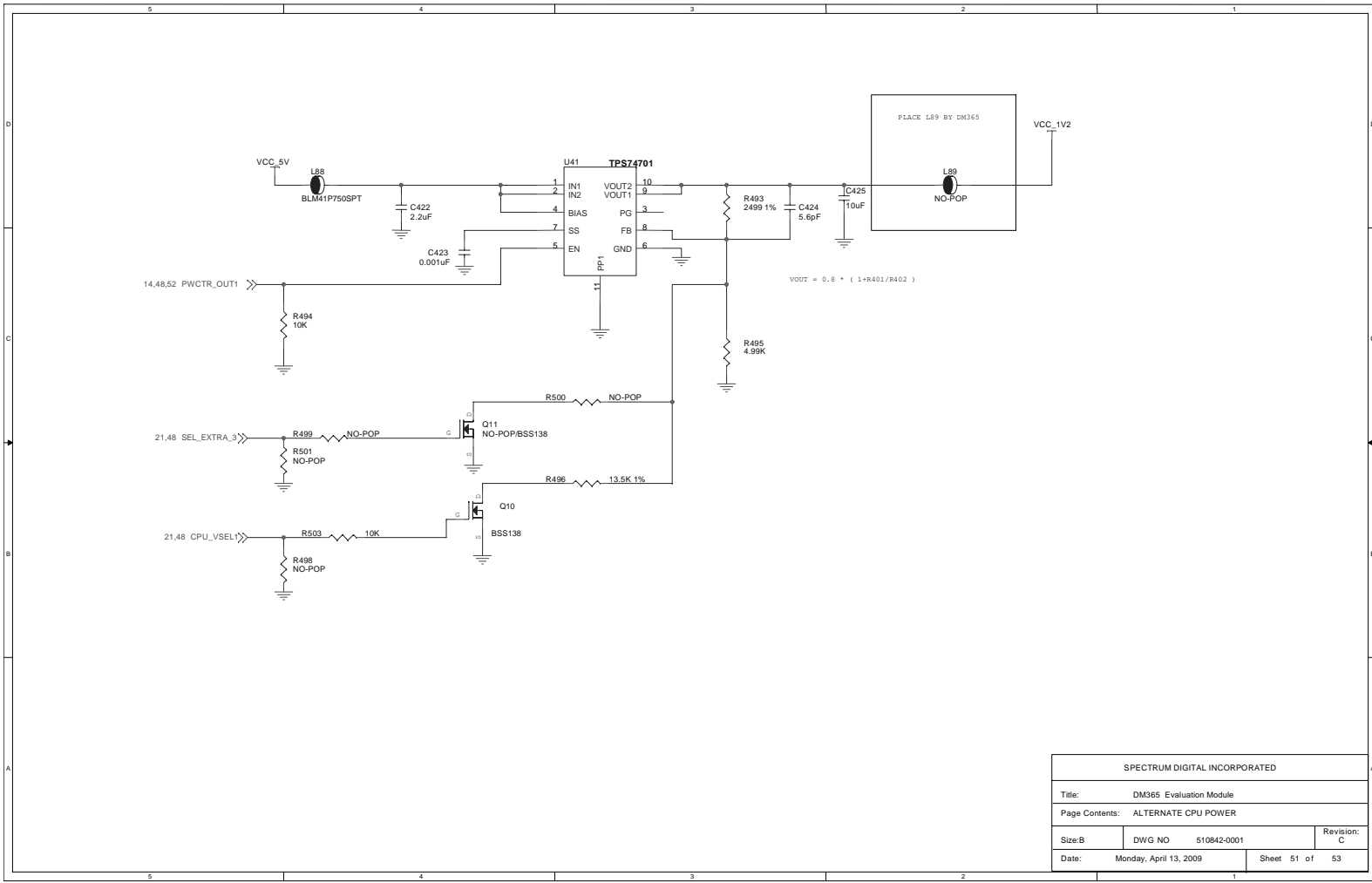

SPECTRUM DIGITAL INCORPORATED		
Title: DM365 Evaluation Module		
Page Contents: ALTERNATE CPU POWER		
Size: B	DWG NO: 510842-0001	Revision: C
Date: Monday, April 13, 2009	Sheet 51 of 53	

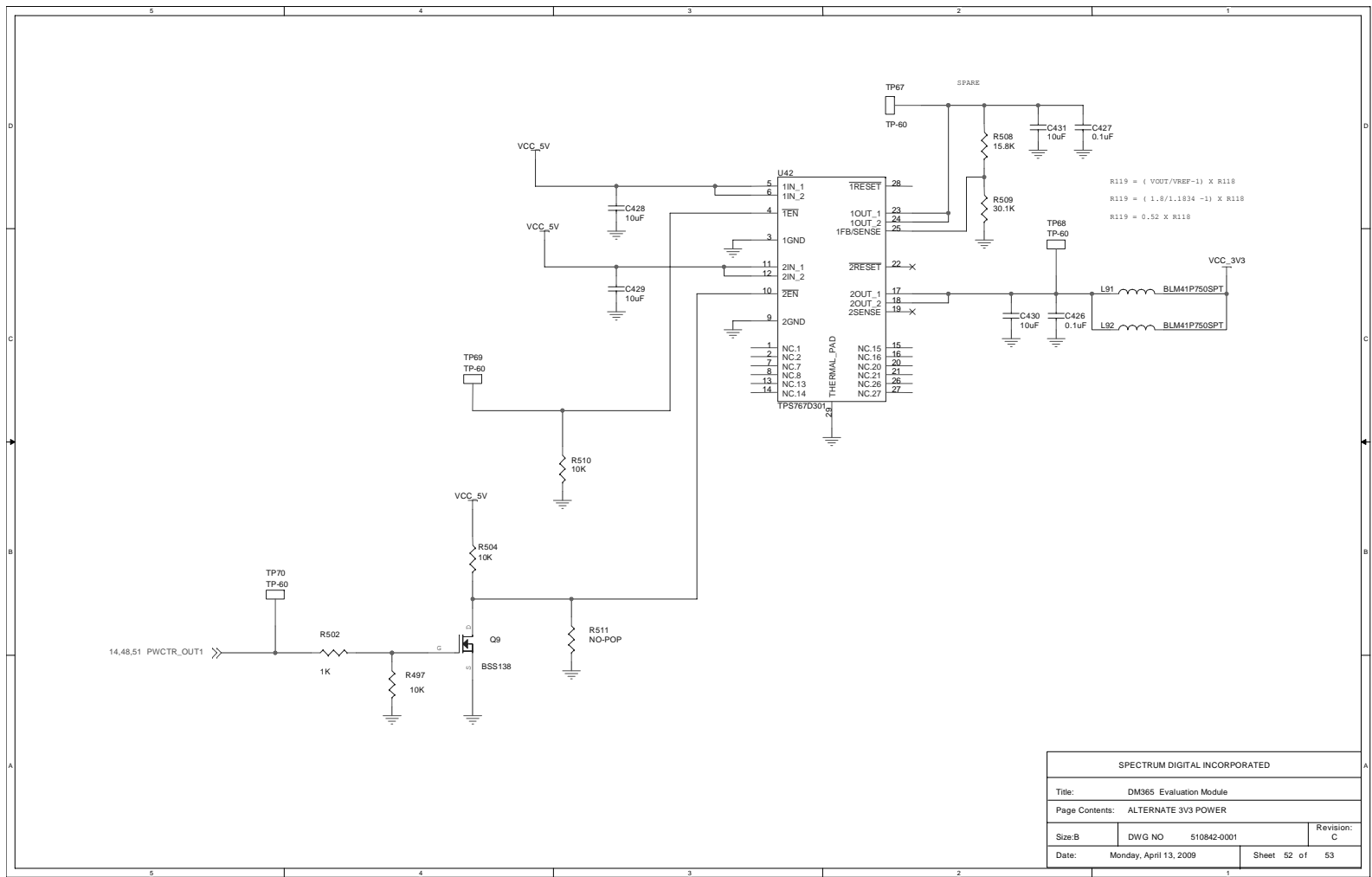

SPECTRUM DIGITAL INCORPORATED			
Title: DM365 Evaluation Module			
Page Contents: ALTERNATE 3V3 POWER			
Size: B	DWG NO	510842-0001	Revision: C
Date: Monday, April 13, 2009	Sheet 52 of 53		

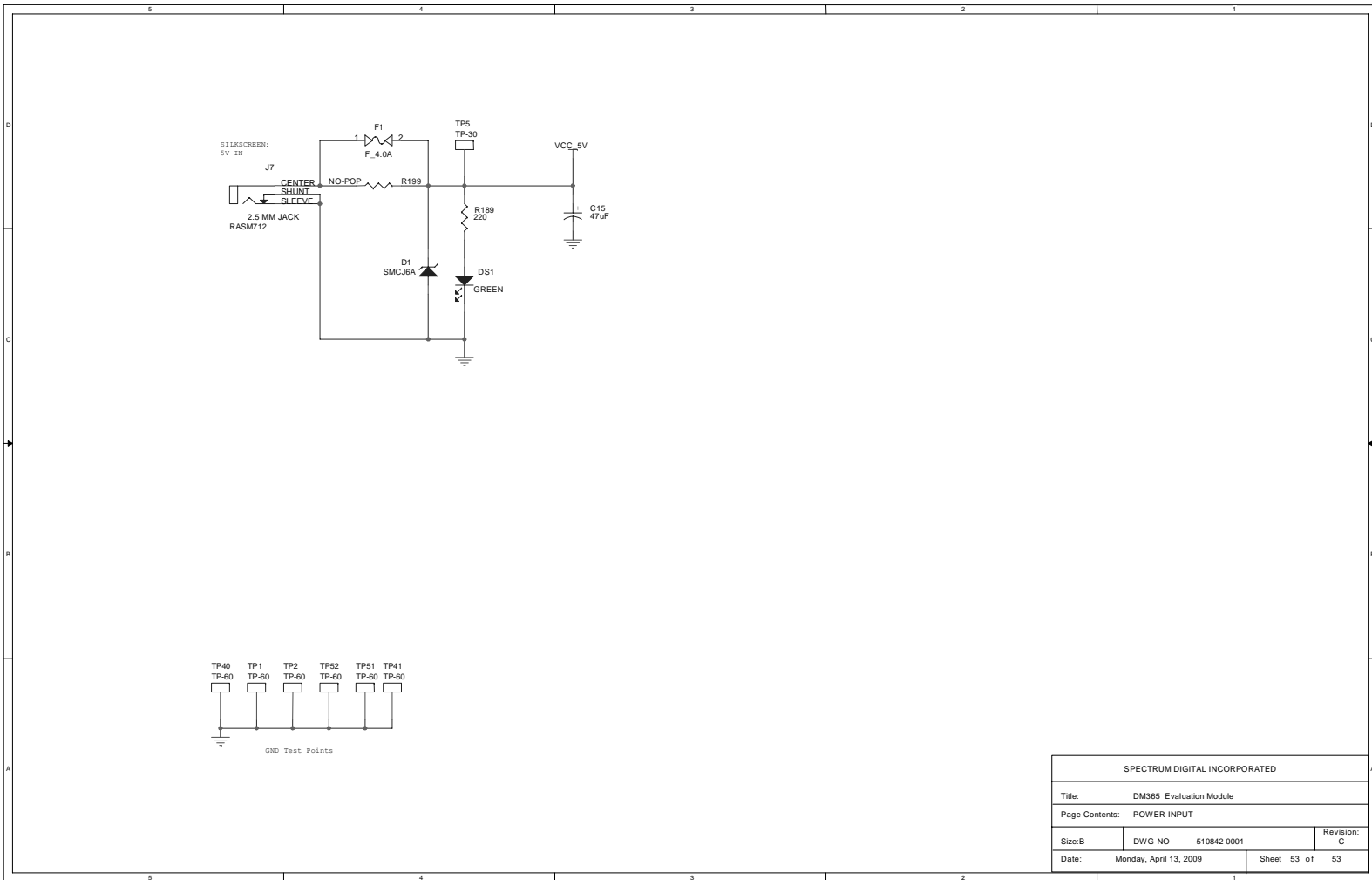

SPECTRUM DIGITAL INCORPORATED		
Title: DM365 Evaluation Module		
Page Contents: POWER INPUT		
Size: B	DWG NO 510842-0001	Revision: C
Date: Monday, April 13, 2009	Sheet 53 of	53

Appendix B

Mechanical Information

This appendix contains the mechanical information about the DM365 EVM produced by Spectrum Digital.

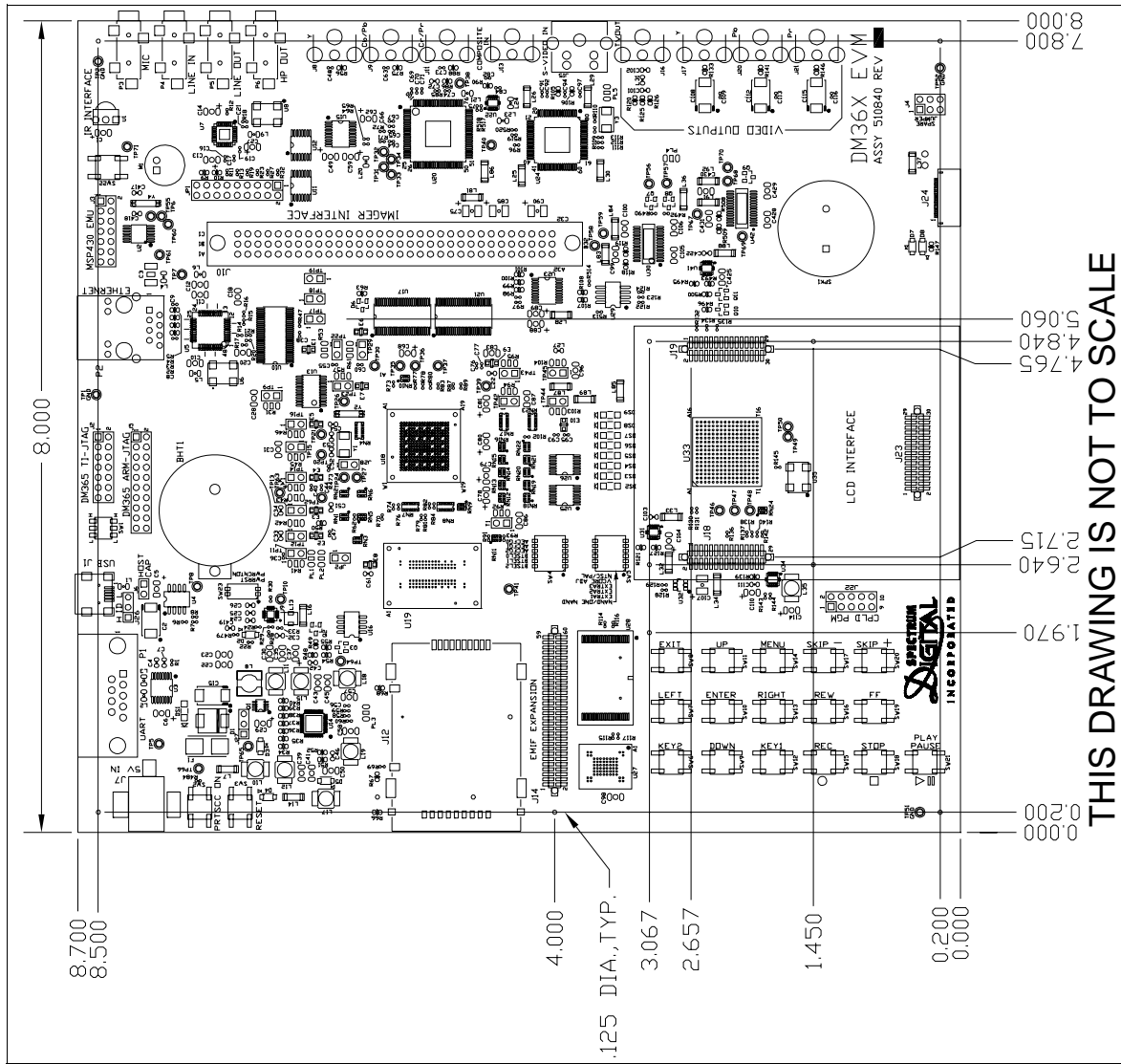

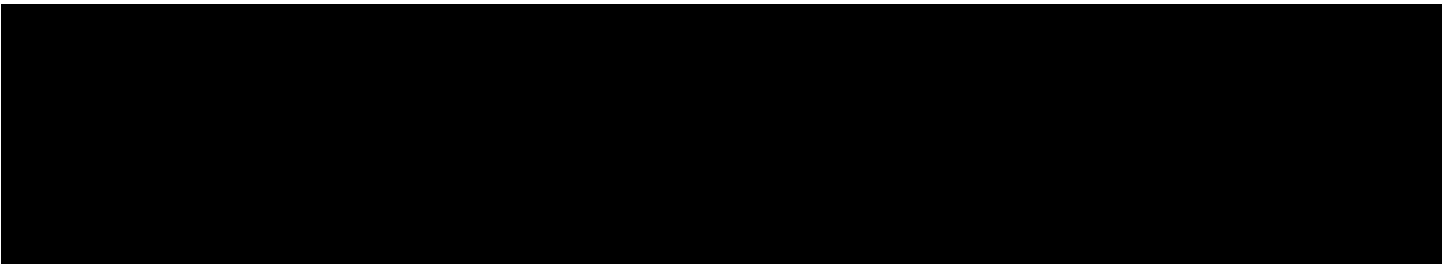

Printed in U.S.A., April 2009
510845-0001 Rev A