

swissbit®

Product Data Sheet

Industrial
SDHC Memory Card

S-220 Series
SPI, SDHC compliant



S-220 Series SDHC Memory Card

1 Feature summary

- Custom-designed, highly-integrated memory controller
 - Fully compliant with SD Memory Card specification 2.0
 - Four integrated 4KByte Sector Buffers for fast data transfer
 - SPI Mode support
- Standard SD Memory Card form factor
 - 32.0mm x 24.0mm x 2.1mm
 - Write Protect slider
- 2.7...3.6V normal operating voltage
- 2.0...3.6V basic communication (CMD0, 15, 55 ACMD41) voltage
- Low-power CMOS technology
- Patented power-off reliability
 - No data loss of older sectors
 - Max. 32 sectors data loss (old data kept) if power off during writing before card status is ready
- Wear Leveling: equal wear leveling of static and dynamic data
The wear leveling assures that dynamic data as well as static data is balanced evenly across the memory. With that the maximum write endurance of the device is guaranteed.
- Write Endurance: Due to intelligent wear leveling an even use of the entire flash is guaranteed, regardless how much "static" (OS) data is stored.
Example: If the average file size is 10MByte and the total capacity is 8GByte, 80Mio write cycles can be performed.
- High reliability
 - Best available SLC NAND Flash technology
 - Designed for embedded market
 - MTBF > 4,000,000 hours
 - Number of card insertions/removals: >10,000
 - Extended Temperature range -25° up to 85°C
 - Optional industrial Temperature range available -40° up to 85°C
- Hot swappable
- High performance
 - SD burst up to 25MB/s
 - SD Low speed 0...25MHz clock rate
 - SD High speed 25...50MHz clock rate
 - 1 or 2 channel flash
 - Flash burst up to 40MB/s per channel
- Available densities
 - 4 and 8GBytes (lower densities are in the SDHC S-200 Series)
- Controlled BOM
- Life Time Monitoring SD/SPI with standard or vendor commands



2 Order Information

2.1 Extended and Industrial Temperature range

Table 1: Product List for standard products

Capacity	Part Number
4GB	SFSD4096LgBN2TO-t-Q2-1x1-STD
8GB	SFSD8192LgBN2TO-t-N2-1x1-STD

g defines the latest product generation,

x defines the latest FW

t defines the temperature range (E=-25°C to +85°C, I=-40°C to +85°C)

2.2 Current product list

Table 2: General Product List

Capacity	Part Number
4GB	SFSD4096L1BN2TO-E-Q2-151-STD
8GB	SFSD8192L1BN2TO-E-N2-151-STD
4GB	SFSD4096L1BN2TO-I-Q2-151-STD
8GB	SFSD8192L1BN2TO-I-N2-151-STD

2.3 Offered options for customer projects

- Customer specified strings and IDs (MID, OID, PNM, PRV)
- Customer specified capacities
- Preload service
- Customized labels
- Customized colors and packages
- permanent write protected with preloaded software
- Option for special FW like:
 - write protection with password (on request)
- SMART-like read out current bad blocks and wear level distribution for life time estimation

Contents

SDHC MEMORY CARD	2
1 FEATURE SUMMARY	2
2 ORDER INFORMATION	3
2.1 INDUSTRIAL TEMPERATURE RANGE $-40^{\circ}\text{C} - +85^{\circ}\text{C}$	3
2.2 OFFERED OPTIONS FOR CUSTOMER PROJECTS	3
3 PRODUCT SPECIFICATION	5
3.1 SYSTEM PERFORMANCE	5
3.2 ENVIRONMENTAL SPECIFICATIONS.....	5
3.2.1 Recommended Operating Conditions.....	5
3.2.2 Recommended Conditions	5
3.2.3 Humidity & ESD	6
3.2.4 Durability.....	6
3.3 PHYSICAL DIMENSIONS.....	6
3.4 RELIABILITY	6
4 CAPACITY SPECIFICATION	6
5 CARD PHYSICAL	7
5.1 PHYSICAL DESCRIPTION	7
6 ELECTRICAL INTERFACE	9
6.1 ELECTRICAL DESCRIPTION	9
6.2 DC CHARACTERISTICS.....	10
6.3 SIGNAL LOADING	10
6.4 AC CHARACTERISTICS	11
7 HOST ACCESS SPECIFICATION	13
7.1 SD AND SPI BUS MODES	13
7.1.1 SD Bus Mode Protocol.....	13
7.1.2 SPI Bus Mode Protocol.....	14
7.1.3 Mode Selection	14
7.2 CARD REGISTERS	15
8 DECLARATION OF CONFORMITY	18
9 ROHS AND WEEE UPDATE FROM SWISSBIT	19
10 PART NUMBER DECODER	21
10.1 MANUFACTURER	21
10.2 MEMORY TYPE.....	21
10.3 PRODUCT TYPE.....	21
10.4 CAPACITY.....	21
10.5 PLATFORM	21
10.6 REVISION	21
10.7 MEMORY ORGANIZATION.....	21
10.8 CONTROLLER TYPE	21
10.9 CHANNELS	21
10.10 FLASH CODE	21
10.11 TEMP. OPTION	22
10.12 DIE CLASSIFICATION.....	22
10.13 PIN MODE.....	22
10.14 CONFIGURATION XYZ.....	22
10.15 OPTION	22
11 SWISSBIT LABEL SPECIFICATION	23
11.1 FRONT SIDE LABEL.....	23
11.2 BACK SIDE LASERING	23
12 REVISION HISTORY	24

3 Product Specification

The SD Memory Card is a small form factor non-volatile memory card which provides high capacity data storage. Its aim is to capture, retain and transport data, audio and images, facilitating the transfer of all types of digital information between a large variety of digital systems.

The Card operates in two basic modes:

- SD card mode
- SPI mode

The SD Memory Card also supports SD **High Speed mode** with up to 50MHz clock frequency.

The cards are compliant with

- SD Memory Card Specification Part 1, Physical layer Specification V2.00
- SD Memory Card Specification Part 2, File System Specification V2.00

The Card has an internal **intelligent controller** which manages interface protocols, data storage and retrieval as well as hardware RS-code **Error Correction Code (ECC), defect handling, diagnostics and clock control.**

The **wear leveling** mechanism assures an equal usage of the Flash memory cells to extend the life time.

The hardware RS-code ECC allows to detect and correct **4 symbols per 528 Bytes.**

The Card has a **voltage detector** and a powerful **power-loss management feature** to prevent data corruption after power-down.

The power consumption is very low.

The data retention is 10 years.

The cards are offered in 2 temperature ranges

- Extended -25°C...85°C
- Industrial -40...85°C on request

The cards are RoHS compliant and lead-free.

3.1 System Performance

Table 3: Performance

System Performance		Typ.	max	Unit
Burst Data transfer Rate (max clock 50MHz)			25 (166X) ⁽¹⁾	MB/s
Sustained Sequential Read	4GB	19 (125X) ⁽¹⁾⁽²⁾	21 (140X) ⁽¹⁾	
	8GB	19 (125X) ⁽¹⁾⁽²⁾	21 (140X) ⁽¹⁾	
Sustained Sequential Write	4GB	17 (110X) ⁽¹⁾⁽²⁾	18 (120X) ⁽¹⁾	
	8GB	17 (110X) ⁽¹⁾⁽²⁾	18 (120X) ⁽¹⁾	

1. ...X are speed grade markings where 1X = 150 kBytes/s. All values refer to Toshiba Flash chips 32Gb or larger SD Memory Card in SD mode 50MHz, cycle time 20ns, write/read file sequential.
2. Sustained Speed measured with Sandisk Mobile mate USB-SD Memory Card reader. It depends on burst speed, flash type and number, and file size

3.2 Environmental Specifications

3.2.1 Recommended Operating Conditions

Table 4: SD Memory Card Recommended Operating Conditions

Parameter	min	typ	max	Unit
Commercial Operating Temperature	0	25	70	°C
Industrial Operating Temperature	-40	25	85	°C
Power Supply VCC (3.3V)	2.7	3.3	3.6	V

Table 5: Current consumption

Current Consumption (type)	typ	max	Unit
Write	81	90	mA
Read	48	60	
Sleep Mode	0.3	0.4	

3.2.2 Recommended Conditions

Table 6: SD Memory Card Recommended Storage Conditions

Parameter	min	typ	max	Unit
Extended Storage Temperature	-40	25	100	°C

Industrial storage Temperature	-40	25	100	°C
--------------------------------	-----	----	-----	----

3.2.3 Humidity & ESD

Table 7: Humidity & ESD

Parameter	Operating	Non Operating
Humidity (non-condensing)	max 95%	
ESD according to IEC61000-4-2 Human body model ±4 kV 100 pf/1.5 kOhm Machine model ±0.25 kV 200 pf/0 Ohm	Non Contact Pads area: ±8 kV (coupling plane discharge) ±15 kV (air discharge) Human body model according to IEC61000-4-2	Contact Pads: ±4 kV, Human body model according to IEC61000-4-2

3.2.4 Durability

Table 8: Durability

Parameter	Operating	Non Operating
Salt water spray	3% NaCl/35°C; 24h acc. MIL STD Method 1009	
Solar Exposure	1000W/m2 @ 400°C	
Impermeability	IP67	
UV Light Exposure	UV: 254nm, 15Ws/cm2	
Insertions	>10,000	
Drop test	1.5m free fall	
Bending	10N	
Torque	0.15Nm or ±2.5deg	
Bump	25g; 6ms; ±3 x 4000 shocks	
Shock	1000 g max.	
Vibration (peak -to-peak)	15G max.	
Minimum moving force of WP slider	0.4N	

3.3 Physical Dimensions

Table 9: Physical Dimensions

Physical Dimensions	Value	Unit
Length	32.00±0.10	mm
Width	24.00±0.10	
Thickness	2.10±0.15	
Weight (typ.)	2	g

3.4 Reliability

Table 10: Reliability

Parameter	Value
Data Retention	10 years (JEDEC47G)

4 Capacity specification

Table 11: SD Memory Card capacity specification

Capacity	Sectors_card	Total addressable capacity (Byte)
4GB	8,087,552	4,140,826,624
8GB	16,226,304	8,307,867,648

5 Card physical

5.1 Physical description

The SD Memory Card contains a single chip controller and Flash memory module(s). The controller interfaces with a host system allowing data to be written to and read from the Flash memory module(s). Figure 1 and Figure 2 show card dimensions.

Figure 1: Mechanical Dimensions SD Memory Card

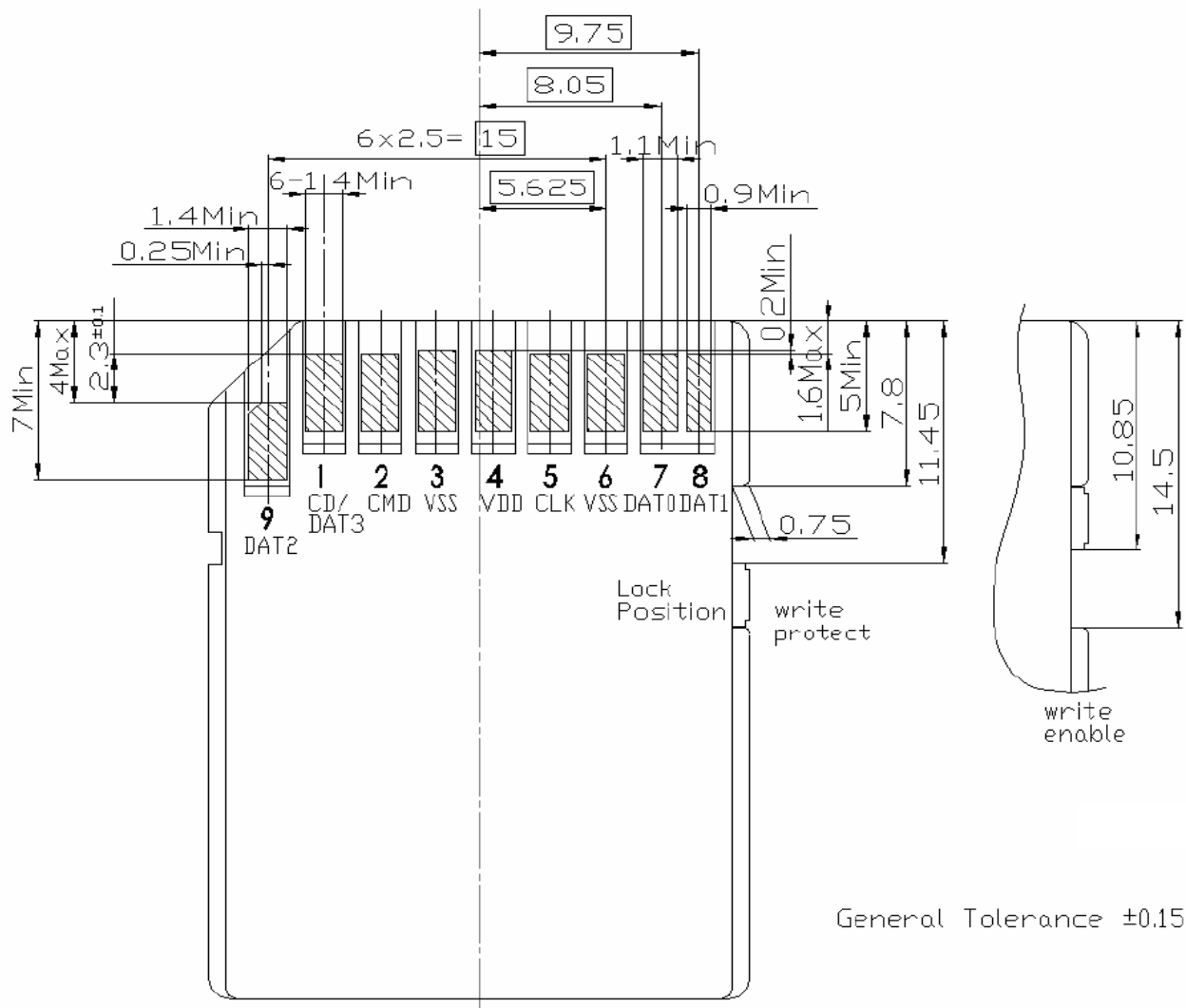
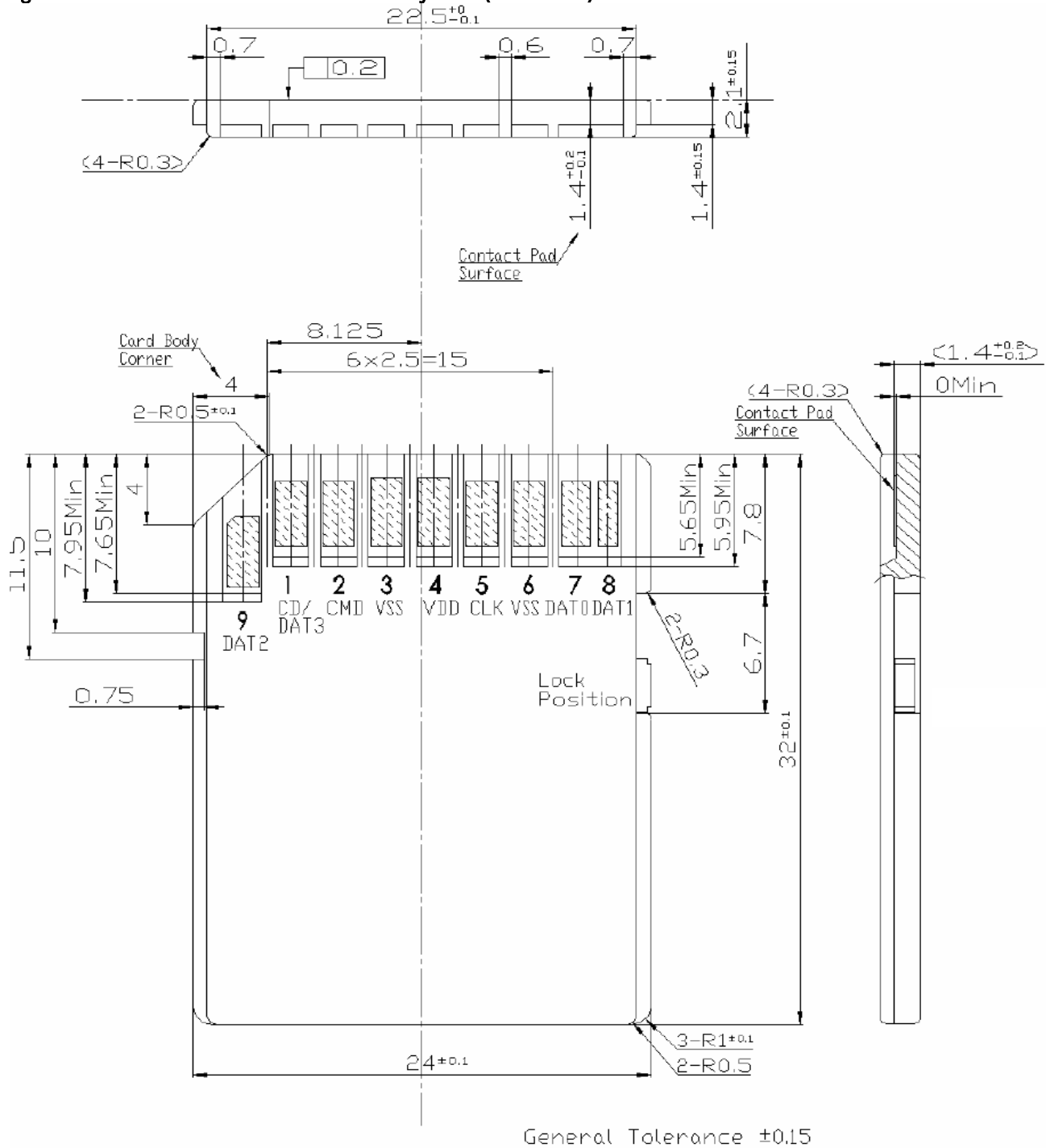

Figure 2: Mechanical Dimensions SD Memory Card (continued)



6 Electrical interface

6.1 Electrical description

Figure 3: SD Memory Card Block Diagram

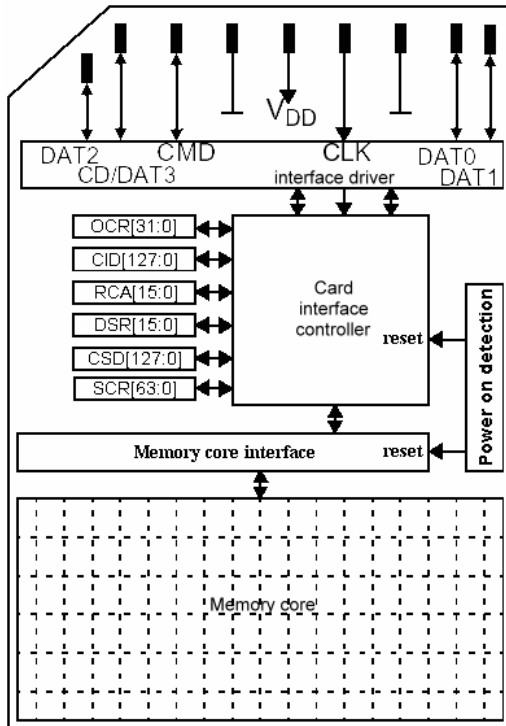

Figure 4: SD Memory Card Shape and Interface (Top View)

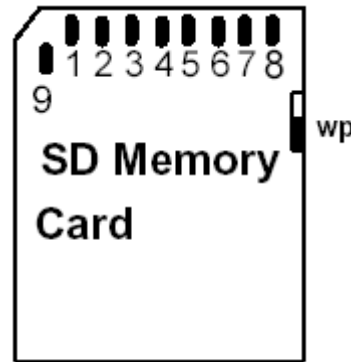

Table 12: SD Memory Card Pad Assignment

Pin #	SD Mode			SPI Mode		
	Name	Type ¹	Description	Name	Type ¹	Description
1	CD/DAT3 ²	I/O/PP ³	Card Detect/ Data Line [Bit 3]	CS	I ³	Chip Select (neg true)
2	CMD	PP	Command/Response	DI	I	Data In
3	VSS1	S	Supply voltage ground	VSS	S	Supply voltage ground
4	VDD	S	Supply voltage	VDD	S	Supply voltage
5	CLK	I	Clock	SCLK	I	Clock
6	VSS2	S	Supply voltage ground	VSS2	S	Supply voltage ground
7	DAT0	I/O/PP	Data Line [Bit 0]	DO	O/PP	Data Out
8	DAT1 ⁴	I/O/PP	Data Line [Bit 1]	RSV		
9	DAT2 ⁵	I/O/PP	Data Line [Bit 2]	RSV		

Notes:

- 1) S: power supply; I: input; O: output using push-pull drivers; PP: I/O using push-pull drivers;
- 2) The extended DAT lines (DAT1–DAT3) are input on power up. They start to operate as DAT lines after SET_BUS_WIDTH command. The Host shall keep its own DAT1–DAT3 lines in input mode, as well, while they are not used.
- 3) At power up this line has a 50kOhm pull up enabled in the card. This resistor serves two functions Card detection and Mode Selection. For Mode Selection, the host can drive the line high or let it be pulled high to select SD mode. If the host wants to select SPI mode it should drive the line low. For Card detection, the host detects that the line is pulled high. This pull-up should be disconnected by the user, during regular data transfer, with SET_CLR_CARD_DETECT (ACMD42) command
- 4) DAT1 line may be used as Interrupt Output (from the Card) in SDIO mode during all the times that it is not in use for data transfer operations (refer to "SDIO Card Specification" for further details).
- 5) DAT2 line may be used as Read Wait signal in SDIO mode (refer to "SDIO Card Specification" for further details).

6.2 DC characteristics

Measurements are at Recommended Operating Conditions unless otherwise specified.

Table 13: DC Characteristics

Symbol	Parameter	Min	Typ	Max	Unit	Notes
	Peak Voltage on all Lines	-0.3		VDD+0.3	V	
VIL	Input LOW Voltage	-0.3		0.25*VDD	V	
VIH	Input HIGH Voltage	0.625*VDD		VDD+0.3	V	
VOL	Output LOW Voltage			0.125*VDD	V	at 100µA
VOH	Output HIGH Voltage	0.75*VDD			V	at 100µA
IDD	Operating Current		35	50	mA	
	Pre-initialization Standby Current			3	mA	
	Post-initialization Standby Current		100	200	µA	
ILI	Input Leakage Current	-10		10	µA	without pull up R
ILO	Output Leakage Current	-10		10	µA	

Table 14: SD Memory Card Recommended Operating Conditions

Symbol	Parameter	Min	Typ	Max	Unit	
VDD	Supply Voltage	Normal Operating Status	2.7		3.6	V
		Basic Communication (CMD0, CMD15, CMD55, ACMD41)	2.0	3.3	3.6	V
VSS1 VSS2	Supply Voltage Differentials	-0.5		0.5	V	
-	Power Up Time (from 0V to VDD min)			250	ms	

6.3 Signal Loading

The total capacitance C_L is the sum of the bus master capacitance C_{HOST} , the bus capacitance C_{BUS} , and the capacitance C_{CARD} of the card connected to the line:

$$C_L = C_{HOST} + C_{BUS} + C_{CARD}$$

To allow the sum of the host and bus capacitances to be up to 20pF for the card, the following conditions in the table below are met by the card.

Table 15: Signal loading

Parameter	Symbol	Min	Max	Unit	Notes
Pull up resistance	R_{CMD}	10	100	kOhm	To prevent bus floating
Pull up resistance	R_{DAT}	10	100	kOhm	To prevent bus floating
Bus signal line capacitance	C_L		40	pF	Single card
Signal card capacitance	C_{card}		10	pF	Single card
Signal line inductance			16	nH	$f \leq 20$ MHz

Figure 5: Signal Loading

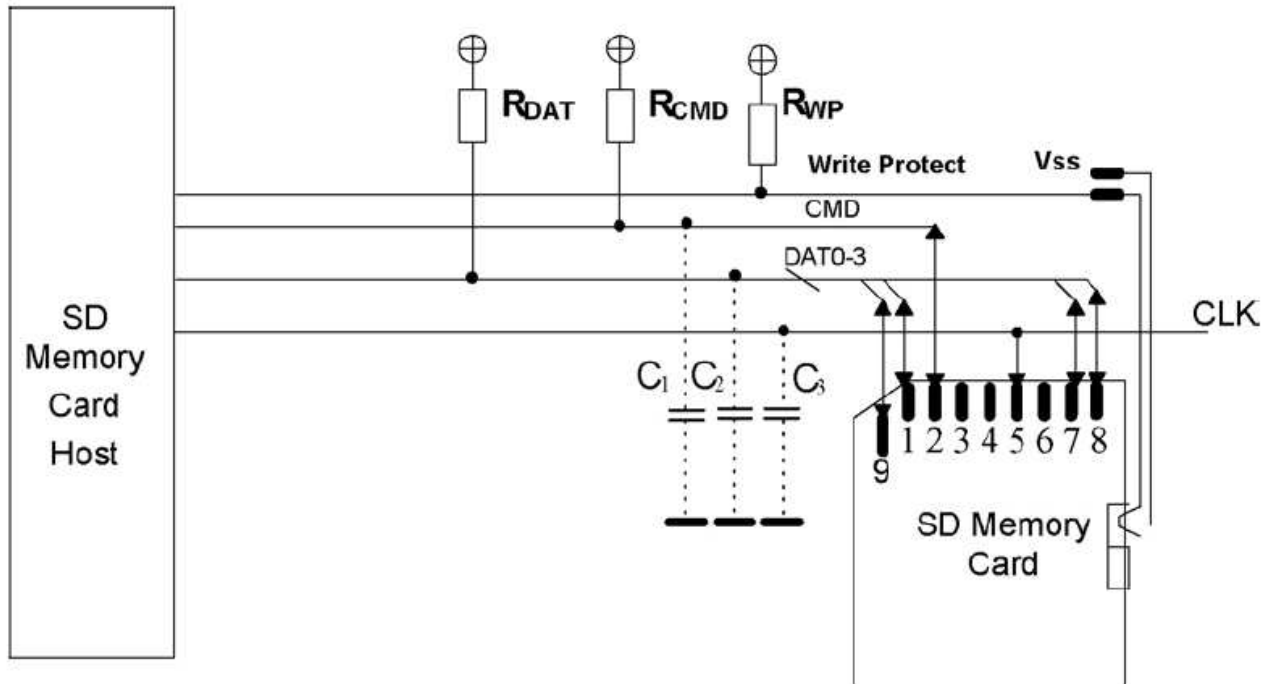

6.4 AC characteristics

Table 16: AC Characteristics Low Speed Mode

Parameter	Symbol	Min	Max	Unit	Notes
Clock frequency in data transfer mode	fPP	0	25	MHz	CL≤100pF
Clock frequency in card id mode	fOD	0	400	KHz	CL≤250pF
Clock low time	tWL	10/50		ns	CL≤100/250pF
Clock high time	tWH	10/50		ns	
Clock rise time	tTLH		10/50	ns	
Clock fall time	tTHL		10/50	ns	
CMD, DAT input setup time	tISU	5		ns	CL≤25pF
CMD, DAT input hold time	tIH	5		ns	
CMD, DAT output delay time	tODLY	0	14	ns	CL≤25pF, data transfer
CMD, DAT output delay time	tODLY	0	50	ns	CL≤25pF, identification

Notes

1. Rise and fall times are measured from 10% to 90% of voltage level.
2. CLK referenced to VIH min and VIL max.
3. CMD and DAT inputs and outputs referenced to CLK.
4. 0Hz means to stop the clock. The given minimum frequency range is for cases where a continuous clock is required
5. Specified for one card

Figure 6: AC Characteristics Low Speed Mode

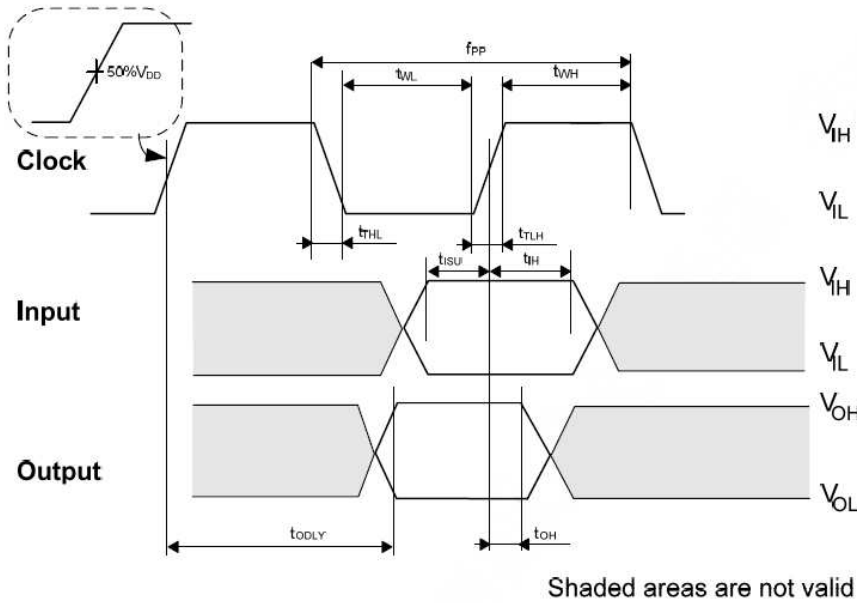

Table 17: AC Characteristics High Speed Mode

Parameter	Symbol	Min	Max	Unit	Notes
Clock frequency in data transfer mode	fPP	0	50	MHz	CL≤10pF
Clock low time	tWL	7.0		ns	
Clock high time	tWH	7.0		ns	
Clock rise time	tTLH		3	ns	
Clock fall time	tTHL		3	ns	
CMD, DAT input setup time	tISU	6		ns	
CMD, DAT input hold time	tIH	2		ns	
CMD, DAT output delay time during data transfer mode	tODLY		14	ns	
CMD, DAT output hold time	tOH	2.5		ns	

Notes

1. Rise and fall times are measured from 10% to 90% of voltage level.
2. CLK referenced to V_{IH} min and V_{IL} max.
3. CMD and DAT inputs and outputs referenced to CLK.
4. In order to satisfy severe timing, the host shall drive only one card with max 40pF total at each line.

Figure 7: AC Characteristics High Speed Mode

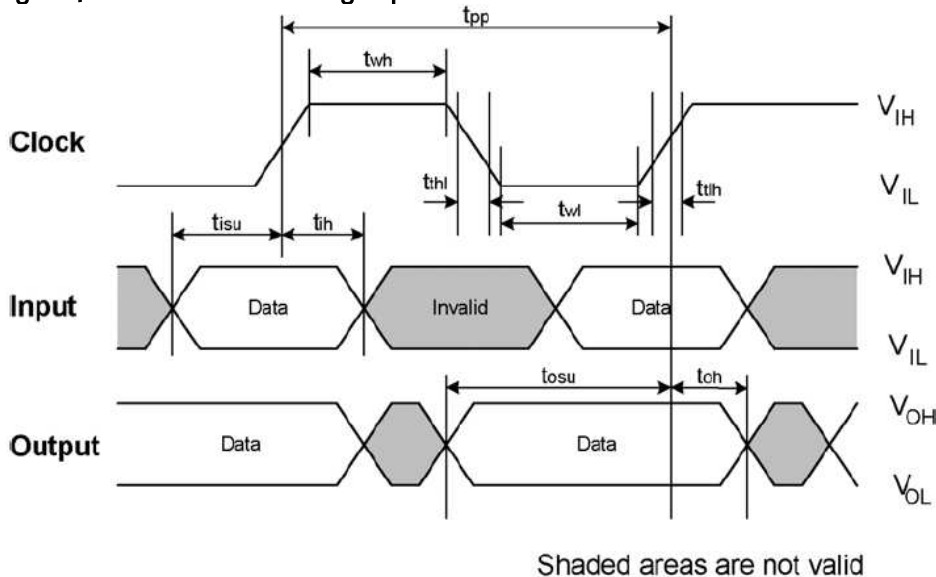

7 Host access Specification

The following chapters summarize how the host accesses the card:

- Chapter 7.1 summarizes the SD and SPI buses.
- Chapter 7.2 summarizes the registers.

7.1 SD and SPI Bus Modes

The card supports SD and the SPI Bus modes. Application can chose either one of the modes. Mode selection is transparent to the host. The card automatically detects the mode of the reset command and will expect all further communication to be in the same communication mode. The SD mode uses a 4-bit high performance data transfer, and the SPI mode provides compatible interface to MMC host systems with little redesign, but with a lower performance.

7.1.1 SD Bus Mode Protocol

The SD Bus mode has a single master (host) and multiple slaves (cards) synchronous topology. Clock, power, and ground signals are common to all cards. After power up, the SD Bus mode uses DAT0 only; after initialization, the host can change the cards' bus width from 1 bit (DAT0) to 4 bits (DAT0-DAT3). In high speed mode, only one card can be connected to the bus.

Communication over the SD bus is based on command and data bit streams which are initiated by a start bit and terminated by a stop bit.

- **Command:** a command is a token which starts an operation. A command is sent from the host either to a single card (addressed command) or to all connected cards (broadcast command). A command is transferred serially on the CMD line.
- **Response:** a response is a token which is sent from an addressed card, or (synchronously) from all connected cards, to the host as an answer to a previously received command. A response is transferred serially on the CMD line.
- **Data:** data can be transferred from the card to the host or vice versa. Data is transferred via the data lines.

The SD bus signals are listed in Table 18, and the SD bus topology is illustrated in Figure 8: SD Bus Topology.

Table 18: SD Bus Signals

Signal	Description
CLK	Host to card clock signal
CMD	Bidirectional Command/Response signal
DAT0-DAT3	4 Bidirectional data signals
Vdd, Vss	Power and Ground

Figure 8: SD Bus Topology

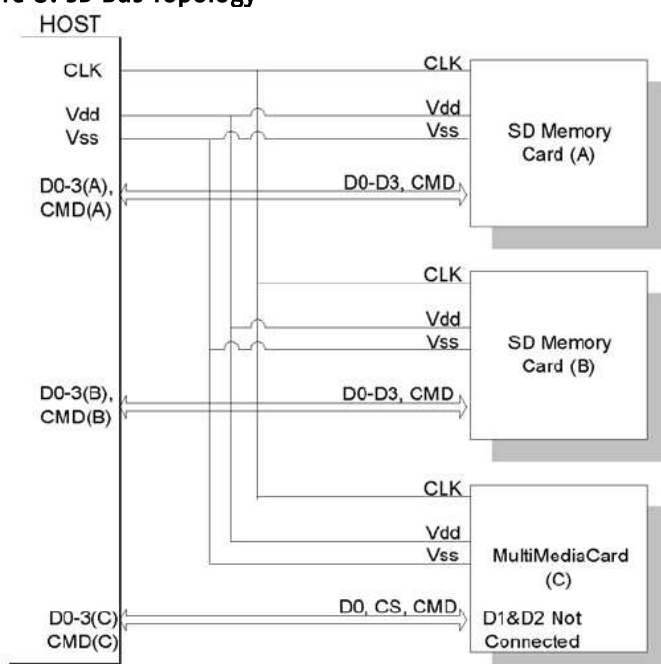

7.1.2 SPI Bus Mode Protocol

The Serial Parallel Interface (SPI) Bus is a general purpose synchronous serial interface. The SPI mode consists of a secondary communication protocol. The interface is selected during the first reset command after power up (CMD0) and it cannot be changed once the card is powered on.

While the SD channel is based on command and data bit streams which are initiated by a start bit and terminated by a stop bit, the SPI channel is byte oriented. Every command or data block is built of 8-bit bytes and is byte aligned to the CS signal.

The card identification and addressing methods are replaced by a hardware Chip Select (CS) signal. There are no broadcast commands. For every command, a card (slave) is selected by asserting (active low) the CS signal. The CS signal must be continuously active for the duration of the SPI transaction (command, response and data). The only exception occurs during card programming, when the host can de-assert the CS signal without affecting the programming process.

The bidirectional CMD and DAT lines are replaced by unidirectional *dataIn* and *dataOut* signals.

The SPI bus signals are listed Table 19 and the SPI bus topology is illustrated in Figure 9.

Table 19: SPI Bus Signals

Signal	Description
/CS	Host to card chip select
CLK	Host to card clock signal
Data In	Host to card data signal
Data Out	Card to host data signal
Vdd, Vss	Power and ground

Figure 9: SPI bus topology

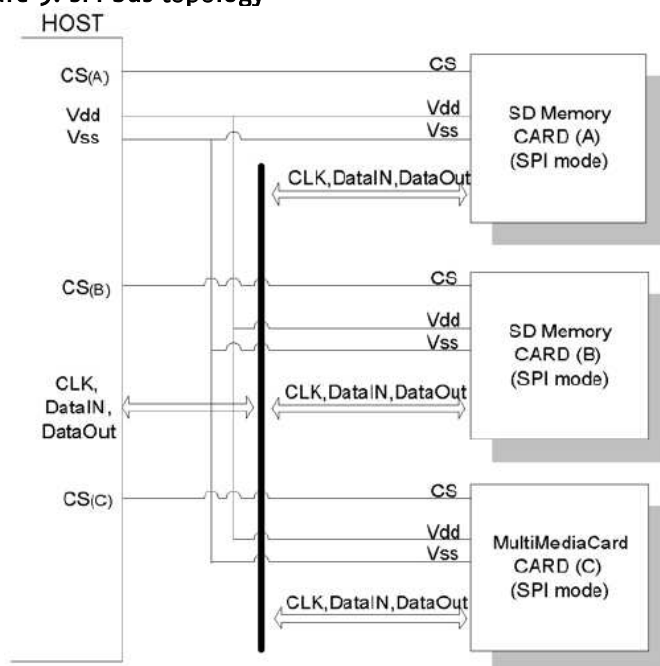

7.1.3 Mode Selection

The SD Memory Card wakes up in the SD mode. It will enter SPI mode if the CS signal is asserted (negative) during the reception of the reset command (CMD0) and the card is in *idle_state*. If the card recognizes that the SD mode is required it will not respond to the command and remain in the SD mode.

If SPI mode is required the card will switch to SPI and respond with the SPI mode R1 response.

The only way to return to the SD mode is by entering the power cycle. In SPI mode the SD Memory Card protocol state machine is not observed. All the SD Memory Card commands supported in SPI mode are always available. During the initialization sequence, if the host gets Illegal Command indication for ACMD41 sent to the card, it may assume that the card is MultiMediaCard. In that case it should re-start the card as MultiMediaCard using CMD0 and CMD1.

7.2 Card Registers

The SD Memory Card has five registers. Refer to Table 20 to Table 25 for detail.

Table 20: SD Memory Card registers

Register Name	Bit Width	Description	Function
CID	128	Card Identification information	This register contains the card identification information used during the Card Identification phase.
OCR	32	Operation Conditions Registers	This register describes the operating voltage range and contains the status bit in the power supply.
CSD	128	Card specific information	This register provides information on how to access the card content. Some fields of this register are writeable by PROGRAM_CSD (CMD27).
SCR	64	SD Memory Card's Special features	This register provides information on special features.
RCA	16	Relative Card Address	This register carries the card address is SD Memory Card mode.

Table 21: CID register

Register Name	Bit Width	Description	typ. value
MID	8	Manufacture ID	0x5d
OID	16	OEM/Application ID	0x5342
PNM	40	Product Name	"L3BNc" c=number of channels
PRV	8	Product Version	0x01 can change
PSN	32	Product Serial Number	xxxxxxxx
—	4	Reserved	0x0
MDT	12	Manufacture Date	oxyym
CRC	7	Check sum of CID contents	chksm
—	1	Not used; always=1	1

Table 22: OCR register

OCR bit position	VDD voltage window	typ. value	OCR bit position	VDD voltage window	typ. value
0-3	Reserved	0	15	2.7-2.8	1
4	1.6-1.7	0	16	2.8-2.9	1
5	1.7-1.8	0	17	2.9-3.0	1
6	1.8-1.9	0	18	3.0-3.1	1
7	1.9-2.0	0	19	3.1-3.2	1
8	2.0-2.1	0	20	3.2-3.3	1
9	2.1-2.2	0	21	3.3-3.4	1
10	2.2-2.3	0	22	3.4-3.5	1
11	2.3-2.4	0	23	3.5-3.6	1
12	2.4-2.5	0	24-30	Reserved	
13	2.5-2.6	0	30	Card Capacity Status (CCS)	*1)
14	2.6-2.7	0	31	o=busy; 1=ready	*2)

Notes

1. This bit is valid only when the card power up status bit is set.
2. This bit is set to LOW if the card has not finished the power up routine.

Table 23: CSD register

Register Name	Bit Width	Description	typ. Value
	>2Gb		>2Gb
CSD_STRUCTURE	2	CSD structure	01
–	6	Reserved	000000
TAAC	8	Data read access time 1	00001110
NSAC	8	Data read access time 2 (CLK cycle)	00000000
TRAN_SPEED	8	Data transfer rate	00110010
CCC	12	Card command classes	010110110101
READ_BLK_LEN	4	Read data block length	1001
READ_BLK_PARTIAL	1	Partial blocks for read allowed	0
WRITE_BLK_MISALIGN	1	Write block misalignment	0
READ_BLK_MISALIGN	1	Read block misalignment	0
DSR_IMP	1	DSR implemented	0
–	6	Reserved	000000
C_SIZE	22	Device size	xxx*)
–	1	Reserved	0
ERASE_BLK_EN	1	Erase single block enable	1
SECTOR_SIZE	7	Erase sector size	1111111
WP_GRP_SIZE	7	Write protect group size	0000000
WP_GRP_ENABLE	1	Write protect group enable	0
–	2	Reserved	00
R2W_FACTOR	3	Write speed factor	010
WRITE_BLK_LEN	4	Write data block length	1001
WRITE_BLK_PARTIAL	1	Partial blocks for write allowed	0
–	5	Reserved	00000
FILE_FORMAT_GRP	1	File format group	0 W(1)
COPY	1	Copy flag	0 W(1)
PERM_WRITE_PROTECT	1	Permanent write protection	0 W(1)
TMP_WRITE_PROTECT	1	Temporary write protection	0 W
FILE_FORMAT	2	File format	00 W(1)
–	2	Reserved	00 W
CRC	7	Checksum of CSD contents	xxxxxxx W
–	1	Always=1	1

*) Drive Size and block sizes vary with card capacity

>2Gb memory capacity = (C_SIZE+1) * 512kByte

W value can be changed with CMD27 (PROGRAM_CSD)

W(1) value can be changed ONCE with CMD27 (PROGRAM_CSD)

Table 24: SCR register

Field	Bit Width	typ Value
SCR_STRUCTURE	4	0000
SD_SPEC	4	0010
DATA_STAT_AFTER_ERASE	1	1
SD_SECURITY	3	011
SD_BUS_WIDTHS	4	0101
Reserved	16	0
Reserved	32	0

Table 25: RCA register

Field	Bit Width	typ Value
RCA	16	0x0000*)

*) After Initialization the card can change the RCA register.

8 Declaration of Conformity

Product Type: SD Memory Card
Brand Name: SWISSMEMORY™ SD Memory Card
Model Designation: SFSDxxxxLxBNxxx-x-xx-xxx-xxx
Manufacturer: Swissbit AG
Industriestrasse 4
CH-9552 Bronschhofen
Switzerland

The product complies with the requirements of the following directives:

Electromagnetic compatibility 2004/108/EC

Emission: EN5022:2006 class B
Immunity: IEC61000-4-2: 2001
EN61000-6-2: 2005 (Electronic Discharge 15kV extended limit)
IEC61000-4-3: 2006

The product was tested according all EMC requirements necessary for -mark

Year of the first marking: 2008

Silvio Muschter, CTO

Bronschhofen, December 1, 2009

9 RoHS and WEEE update from Swissbit

Dear Valued Customer,

We at Swissbit place great value on the environment and thus pay close attention to the diverse aspects of manufacturing environmentally and health friendly products. The European Parliament and the Council of the European Union have published two Directives defining a European standard for environmental protection. This states that CompactFlash Cards must comply with both Directives in order for them to be sold on the European market:

- **RoHS** – Restriction of Hazardous Substances
- **WEEE** – Waste Electrical and Electronic Equipment

Swissbit would like to take this opportunity to inform our customers about the measures we have implemented to adapt all our products to the European norms.

What is the WEEE Directive (2002/96/EC)?

The Directive covers the following points:

- Prevention of WEEE
- Recovery, recycling and other measures leading to a minimization of wastage of electronic and electrical equipment
- Improvement in the quality of environmental performance of all operators involved in the EEE life cycle, as well as measures to incorporate those involved at the EEE waste disposal points

What are the key elements?

The WEEE Directive covers the following responsibilities on the part of producers:

Producers must draft a disposal or recovery scheme to dispose of EEE correctly.
Producers must be registered as producers in the country in which they distribute the goods.
They must also supply and publish information about the EEE categories.
Producers are obliged to finance the collection, treatment and disposal of WEEE.

Inclusion of WEEE logos on devices

In reference to the Directive, the WEEE logo must be printed directly on all devices that have sufficient space. «In exceptional cases where this is necessary because of the size of the product, the symbol of the WEEE Directive shall be printed on the packaging, on the instructions of use and on the warranty» (WEEE Directive 2002/96/EC)

When does the WEEE Directive take effect?

The Directive came into effect internationally on 13 August, 2005.

What is RoHS (2002/95/EC)?

The goals of the Directive are to:

- Place less of a burden on human health and to protect the environment by restricting the use of hazardous substances in new electrical and electronic devices
- To support the WEEE Directive (see above)

RoHS enforces the restriction of the following 6 hazardous substances in electronic and electrical devices:

- Lead (Pb) – no more than 0.1% by weight in homogeneous materials
- Mercury (Hg) – no more than 0.1% by weight in homogeneous materials
- Cadmium (Cd) – no more than 0.01% by weight in homogeneous materials
- Chromium (Cr6+) – no more than 0.1% by weight in homogeneous materials
- PBB, PBDE – no more than 0.1% by weight in homogeneous materials

Swissbit is obliged to minimize the hazardous substances in the products.

According to part of the Directive, manufacturers are obliged to make a self-declaration for all devices with RoHS. Swissbit carried out intensive tests to comply with the self-declaration. We have also already taken steps to have the analyses of the individual components guaranteed by third-party companies.

Swissbit carried out the following steps during the year with the goal of offering our customers products that are fully compliant with the RoHS Directive.

- **Preparing all far-reaching directives, logistical enhancements and alternatives regarding the full understanding and introduction of the RoHS Directive's standards**
- **Checking the components and raw materials:**
 - Replacing non-RoHS-compliant components and raw materials in the supply chain
 - Cooperating closely with suppliers regarding the certification of all components and raw materials used by Swissbit
- **Modifying the manufacturing processes and procedures**
 - Successfully adapting and optimizing the new management-free integration process in the supply chain
 - Updating existing production procedures and introducing the new procedures to support the integration process and the sorting of materials
- **Carrying out the quality process**
 - Performing detailed function and safety tests to ensure the continuous high quality of the Swissbit product line

When does the RoHS Directive take effect?

As of 1 July, 2006, only new electrical and electronic devices with approved quantities of RoHS will be put on the market.

When will Swissbit be offering RoHS-approved products?

Swissbit's RoHS-approved products are available now. Please contact your Swissbit contact person to find out more about exchanging your existing products for RoHS-compliant devices.

For your attention

We understand that packaging and accessories are not EEE material and are therefore not subject to the WEEE or RoHS Directives.

Contact details:

Swissbit AG
Industriestrasse 4
CH 9552 Bronschhofen
Tel: +41 71 913 03 03 – Fax: +41 71 913 03 15
E-mail: industrial@swissbit.com – Website: www.swissbit.com

10 Part Number Decoder

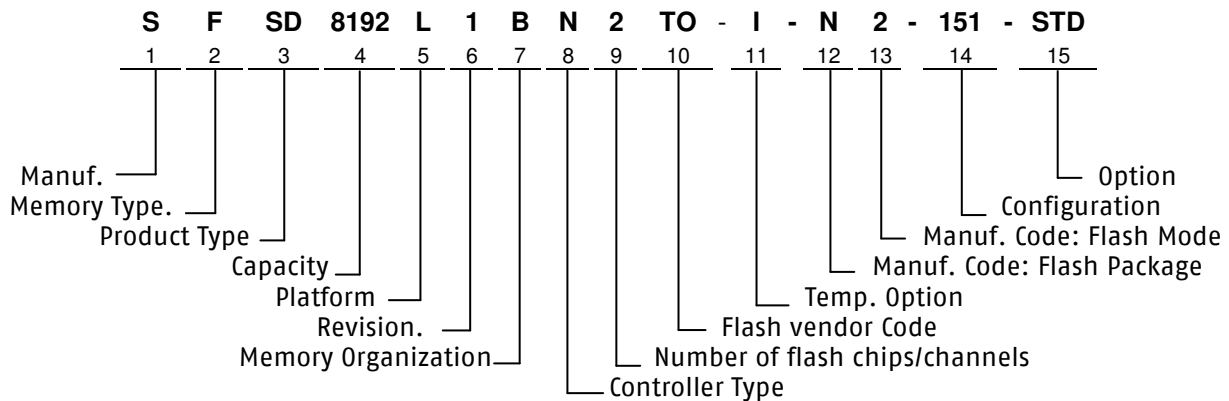

10.1 Manufacturer

Swissbit code	S
---------------	---

10.2 Memory Type

Flash	F
-------	---

10.3 Product Type

SD Memory Card	SD
----------------	----

10.4 Capacity

4 GB	4096
8 GB	8192
16 GByte	16GB
32 GByte	32GB

10.5 Platform

SD Memory Card	L
----------------	---

10.6 Revision

10.7 Memory Organization

x8	B
x16	C

10.8 Controller type

SD Memory Card controller	S-2x0 series	N
---------------------------	--------------	---

10.9 Channels

1 Flash Channel	1
2 Flash Channel	2

10.10 Flash Code

Samsung	SA
Toshiba	TO

10.11 Temp. Option

Industrial Temp. Range -40°C – 85°C	I
Extended Temp. Range -25°C – 85°C	E

10.12 DIE Classification

SLC MONO (single die package)	M
SLC DDP (dual die package)	D
SLC QDP (quad die package)	Q
SLC ODP (octal die package)	N

10.13 PIN Mode

Normal nCE & R/nB	0
Dual nCE & Dual R/nB	1
Quad nCE & Quad R/nB	2

10.14 Configuration XYZ

X → Configuration

Configuration	X
default	1

Y → FW Revision

FW Revision	Y
Revision 1	1
Revision 2	2
Revision 3	3
Revision 4	4
Revision 5	5

Z → optional

Optional	Z
optional	1

10.15 Option

Swissbit / Standard	STD
---------------------	-----

11 Swissbit Label specification

11.1 Front side label

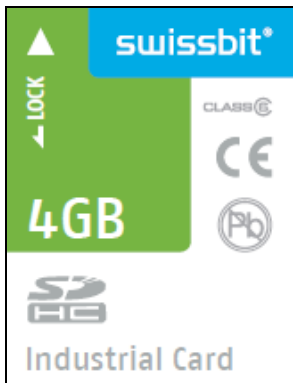

4GB SDHC Memory Card – class 6

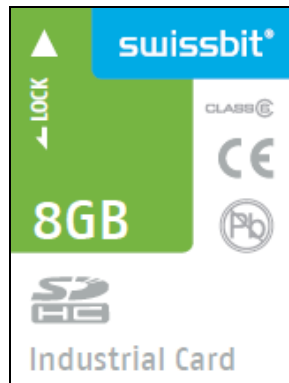

8GB SDHC Memory Card – class 6

11.2 Back side lasering

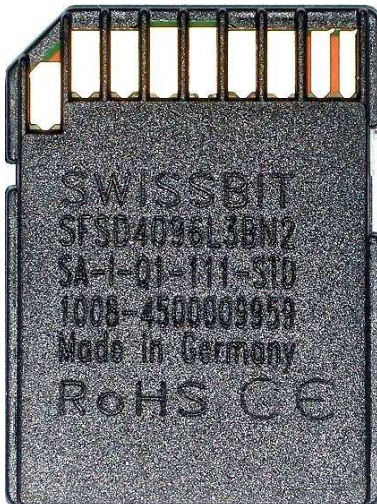

SWISSBIT

SFSD4096L3BN2
 SA-I-Q1-111-STD
 1008-4500009959
 Made in Germany
 RoHS CE

Part-
 number
 Date-Lot/Serial

12 Revision History

Table 26: Document Revision History

Date	Revision	Revision Details
April 13, 2010	1.00	S-220 cards with Toshiba flash
September 28, 2010	1.01	SDHC 4GB PN with Q2 instead of Q1, higher storage temperature for extended cards
January 03, 2012	1.02	Performance value updated, label and lasering update
April 27, 2012	1.10	SDA Correction, CI update

Disclaimer:

No part of this document may be copied or reproduced in any form or by any means, or transferred to any third party, without the prior written consent of an authorized representative of Swissbit AG ("SWISSBIT"). The information in this document is subject to change without notice. SWISSBIT assumes no responsibility for any errors or omissions that may appear in this document, and disclaims responsibility for any consequences resulting from the use of the information set forth herein. SWISSBIT makes no commitments to update or to keep current information contained in this document. The products listed in this document are not suitable for use in applications such as, but not limited to, aircraft control systems, aerospace equipment, submarine cables, nuclear reactor control systems and life support systems. Moreover, SWISSBIT does not recommend or approve the use of any of its products in life support devices or systems or in any application where failure could result in injury or death. If a customer wishes to use SWISSBIT products in applications not intended by SWISSBIT, said customer must contact an authorized SWISSBIT representative to determine SWISSBIT willingness to support a given application. The information set forth in this document does not convey any license under the copyrights, patent rights, trademarks or other intellectual property rights claimed and owned by SWISSBIT. The information set forth in this document is considered to be "Proprietary" and "Confidential" property owned by SWISSBIT.

ALL PRODUCTS SOLD BY SWISSBIT ARE COVERED BY THE PROVISIONS APPEARING IN SWISSBIT'S TERMS AND CONDITIONS OF SALE ONLY, INCLUDING THE LIMITATIONS OF LIABILITY, WARRANTY AND INFRINGEMENT PROVISIONS. SWISSBIT MAKES NO WARRANTIES OF ANY KIND, EXPRESS, STATUTORY, IMPLIED OR OTHERWISE, REGARDING INFORMATION SET FORTH HEREIN OR REGARDING THE FREEDOM OF THE DESCRIBED PRODUCTS FROM INTELLECTUAL PROPERTY INFRINGEMENT, AND EXPRESSLY DISCLAIMS ANY SUCH WARRANTIES INCLUDING WITHOUT LIMITATION ANY EXPRESS, STATUTORY OR IMPLIED WARRANTIES OF MERCHANTABILITY OR FITNESS FOR A PARTICULAR PURPOSE.

©2012 SWISSBIT AG All rights reserved.