

Optional:
 Deutsch Connector
 P/N: DT04-4P-E004
 W4P Wedgelock
 0460-215-16141 Terminals

PIN	WIRE COLOR	FUNCTION	WIRE GA.	WIRE TYPE
1	Black	Ground	14	GXL
2	Red	Power	14	GXL
3	Yellow	Secondary Signal	18	GXL
4	White	Primary Signal	14	GXL

MAGNETIC PROXIMITY SENSOR

Part No.: 049

High Power

Sensing Position: Top

For Use with Noram Part No. 059

PROPERTY OF NORAM

NOTES

25 AMP Load Rate

Switch: Magnasphere 250 MA@30 vdc

Housing Materials: ABS

Contact Form: NC (Form B)

NORAM

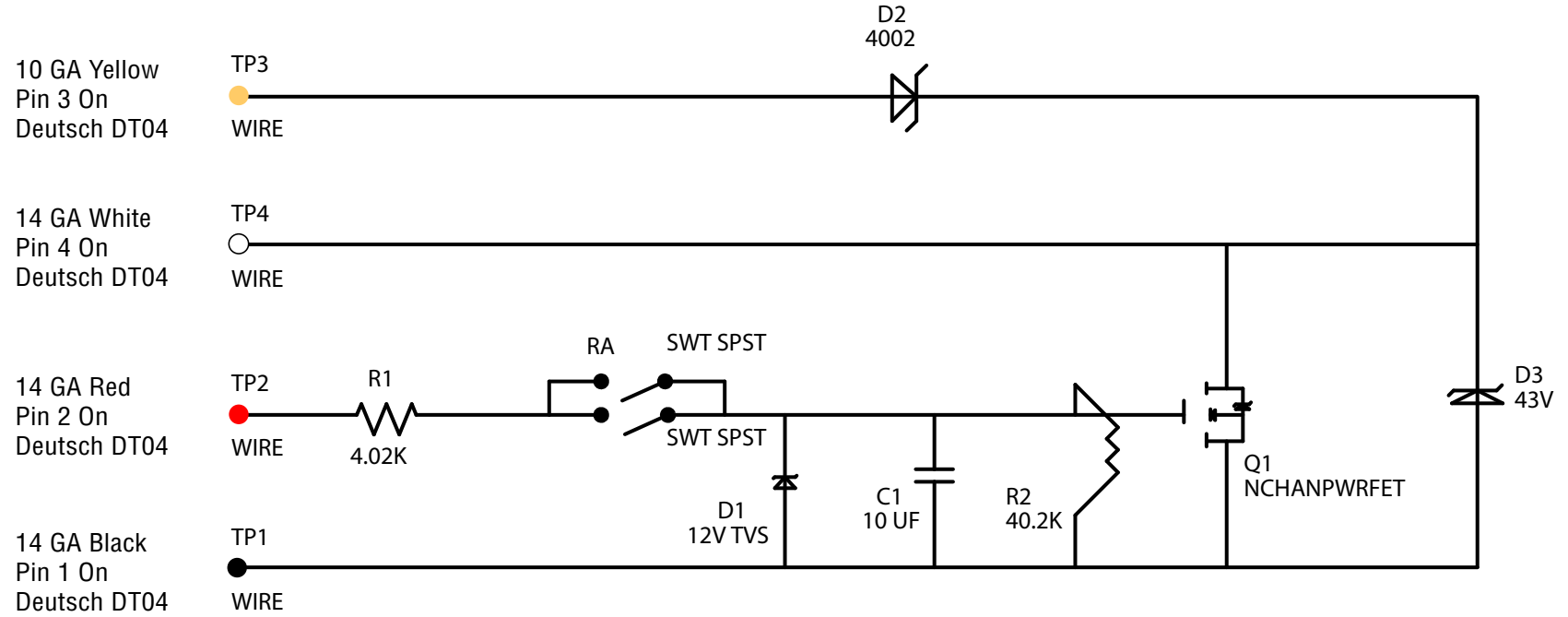

MAGNETIC PROXIMITY SENSOR

Part No.: 049

High Power

Sensing Position: Top

For Use with Noram Part No. 059

PROPERTY OF NORAM

