



MAGNASPHERE® HSS®



MAGNASPHERE has Created the L2 Series HSS® “High Security Sensor” – **The Next Generation Sensors That Meet UL 634 Level 2 High Security Standards** for SCIFs, Safes and Vaults and All Other High Level Secure Applications.



THE INSIDER THREAT

IS REAL. Experts agree that the most devastating threats to government and corporate security have come from employees who were deemed trusted insiders. Armed with simple magnets unscrupulous insiders can disable even triple-balanced BMS magnetic contacts while the system is unarmed, and enter undetected at a later time, leaving no evidence of tamper.

The MAGNASPHERE HSS meets the UL 634 Level 2 High Security Standard.

MAGNASPHERE L2 HSS Technology

- Resistant to External and INTERNAL magnetic defeat
- Built-in EOL resistors available
- Unique cross hole mounting feature eliminates need for L and Z brackets on most installations
- Retro-fit for existing BMS devices
- No adjustment required for installation
- Industry’s most secure removal tamper sensor / circuit
- MAGNASPHERE switch technology resists permanent contact welding (lightning, power surges, stun guns)
- Single and dual alarm contacts available
- American made using award-winning MAGNASPHERE switch technology
- Compatible with control panel models that accept contact inputs
- Competitively priced
- INTRINSICALLY SAFE, Simple Apparatus (see page 4)



MAGNASPHERE® HSS®

L2 HSS DIMENSIONS

- [L] 4.25" (107.9 mm)
- [H] 1.5" (38.1 mm)
- [D] 1.0" (25.4 mm)
- [S] 3.5" (88.9 mm)
- [S1] 0.75" (19.1 mm)
- [P] 0.84" (21.3 mm)
- [P1] 0.52" (13.2 mm)
- [E] 3.03" (76.9 mm)
- [C] 36.0" (914.4 mm) x 0.30" (7.6 mm)
Stainless Steel Cable
- [A] 0.125" (3.18 mm)
Actuation Gap
(recommended for maximum internal magnetic non-defeat characteristics)

CONSTRUCTION AND TECHNICAL SPECIFICATIONS

- Aluminum Case: Silver-Gray Anodized
- Wire Lead Type: Solid Color-Coded Lead Wires, 22 AWG
- Hermetically Sealed Switch Contacts
- Fully Epoxy Potted Assembly
- Single Alarm Contact Version (L2 S): Closed or Open Loop
- Dual Alarm Contact Version (L2 D): Closed Loop
- Removal Tamper Circuit: Closed Loop
- Max Current: 0.25 A Resistive
- Max Voltage: 30 VDC
- Max Power: 0.250 W
- Operating Temperature: -40° C to +80° C
- Suitable for Indoor and Outdoor Use
- Intended for Connection to UL Listed Compatible Control Panels

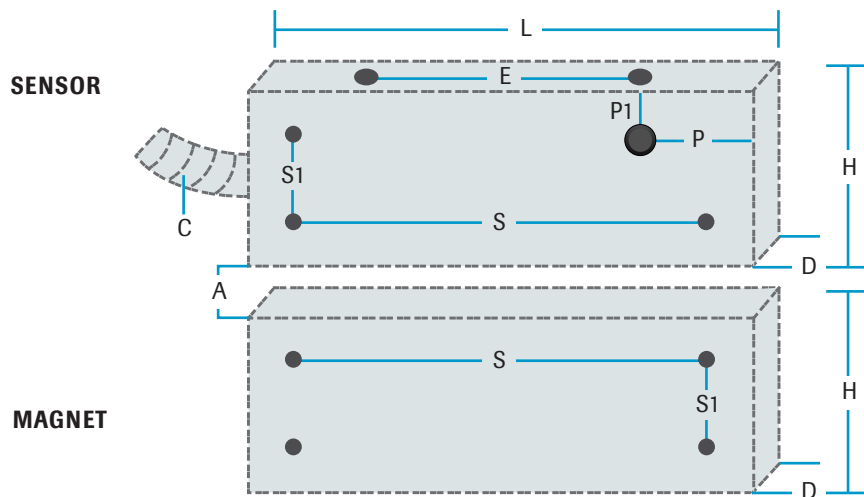

PATENTED DESIGN

- #5332992 #5530428
- #5673021 #5880659
- #5977873 #6087936
- #6506987 #6603378
- #6803845 #7023308
- #7291794 #RE39731
- #7944334 #8228191
- & Other Patents Pending

MAGNASPHERE® Corp. provides superior performing magnetic contact sensor technology for the residential, commercial, and federal government security markets. The HSS's leading-edge technology aims to set new industry standards for high security sensors while providing an affordable and more effective alternative to reed-based security contacts.

To learn more about the MAGNASPHERE® L2 HSS High Security Sensor visit www.MAGNASPHERE.com or call 262-347-0711.



How the HSS Magnet / Removal Tamper Circuit Works

The MAGNASPHERE HSS Incorporates the Most Secure Anti-Tamper Features of Any Device Available.

In addition to the sensors inside that will detect the presence of a stronger defeat magnet placed on any surface of the HSS, the removal tamper circuit will alarm BEFORE the HSS can be removed.

You will notice that the mounting hole on the upper right face of the HSS sensor is larger than the other mounting holes and slightly off set towards the center of the sensor. A tamper proof MAGNASPHERE switch is positioned inside the unit facing the bore of this mounting hole.

Whether you use the four mounting holes on the face of the sensor (in-swinging doors), or the two mounting holes on the bottom of the sensor (out-swinging doors), the upper right mounting hole with the removal tamper switch will be used.

Once the unit has been mounted, the removal tamper magnet (included) is inserted into this mounting hole. It will be attracted to the mounting screw and will activate the removal tamper switch. The mounting hole cover cap (included) is then inserted and locked into position.

In order to access that mounting screw to remove the sensor, the locking cap must be pried out, and a steel rod or magnet inserted into the hole to extract the tamper magnet. Removal of the tamper magnet will cause the removal tamper switch to alarm.

The HSS also includes anti-rotation pins that will prevent an intruder from removing the non-removal tamper mounting screws and twisting the HSS into a position where another door actuating magnet could be placed, simulating a secure position.

Unique Cross-Hole Mounting Feature Eliminates Need for L or Z Brackets on Most Out-Swinging Doors

A Unique Feature of the MAGNASPHERE HSS is the Two Mounting Holes Located on the Bottom Surface of the Sensor that Faces the Actuating Magnet.

Using these mounting holes allows the installation of the sensor directly to the door stop, eliminating the need for an L bracket.

The actuation magnet is then mounted directly to the surface of the door so that it lines up beneath the door stop mounted sensor, eliminating the need for a Z bracket.

Depending on the “play” in the door to stop fit, it may be necessary to use a magnet spacer(s) (available from MAGNASPHERE) to insure proper alignment between sensor and magnet.

On in-swinging doors (flush to frame), the HSS sensor is mounted directly to the door frame, and the actuation magnet is mounted directly to the door.



Model L2 S Series

HSS PART NUMBERING SYSTEM L2S-XXX

Single Alarm Contact Either Closed or Open Loop, with Tamper Circuit, Closed Loop.

All Circuits Shown with Magnet Actuator in Secure Position.

For Built-in EOL Resistor Configurations and Values not Shown. Contact Magnasphere Corp.

Model L2S-000

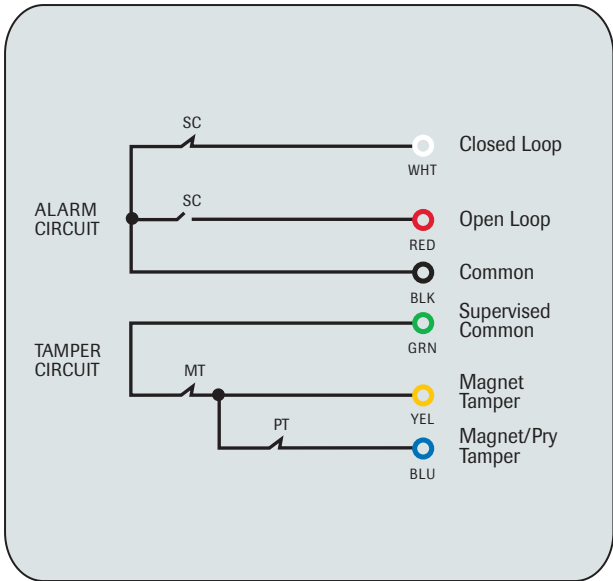

Model L2S-001

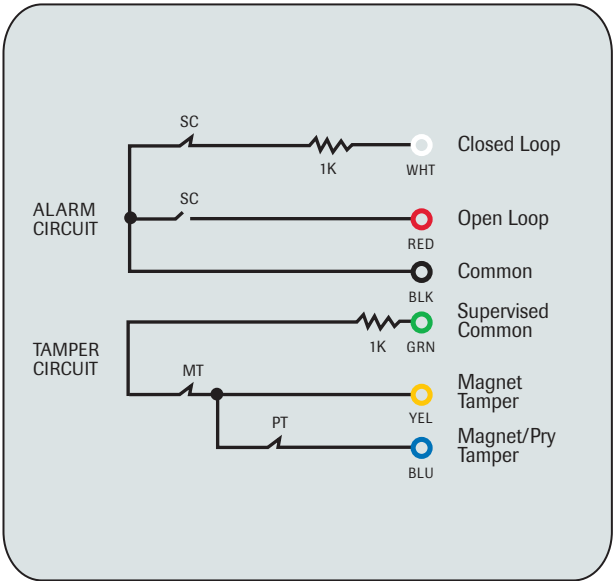

Model L2S-003

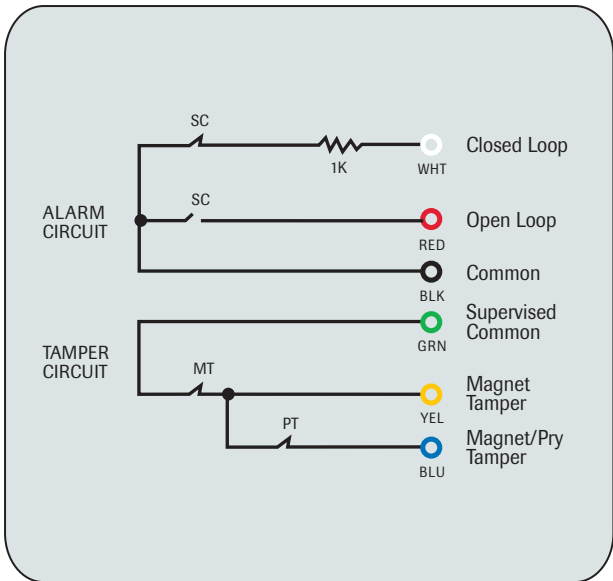

Model L2S-002

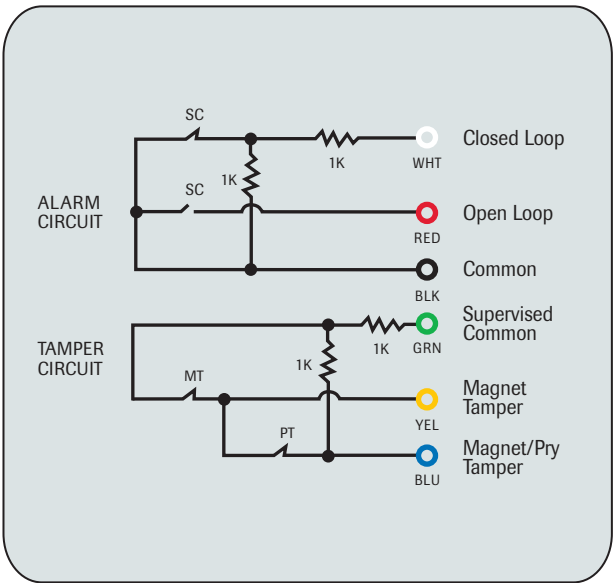

Model L2S-004

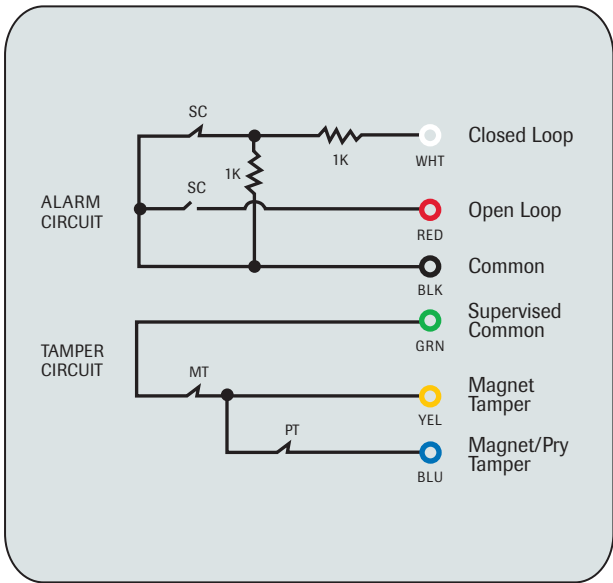



Model L2 D Series

HSS PART NUMBERING SYSTEM L2D-XXX

Dual Alarm Contacts Both Closed Loop, with Tamper Circuit, Closed Loop.

All Circuits Shown with Magnet Actuator in Secure Position.

For Built-in EOL Resistor Configurations and Values not Shown. Contact MagnaspHERE Corp.

Model L2D-000

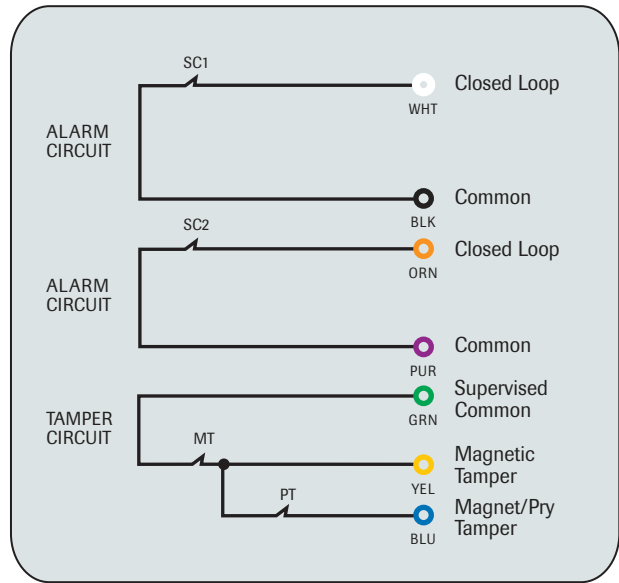

Model L2D-001

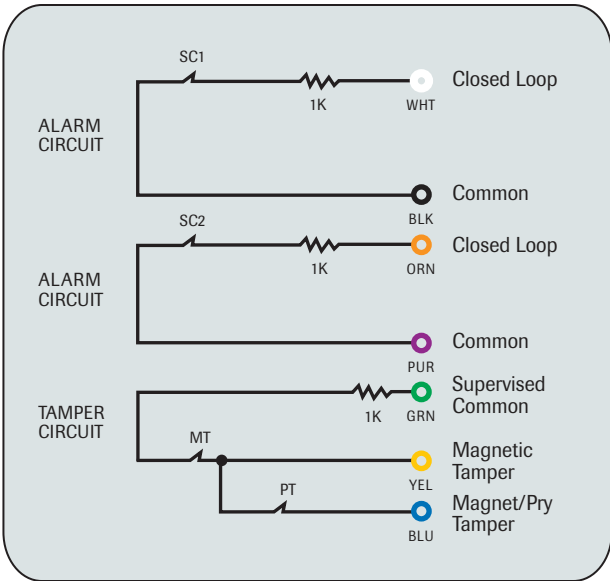

Model L2D-003

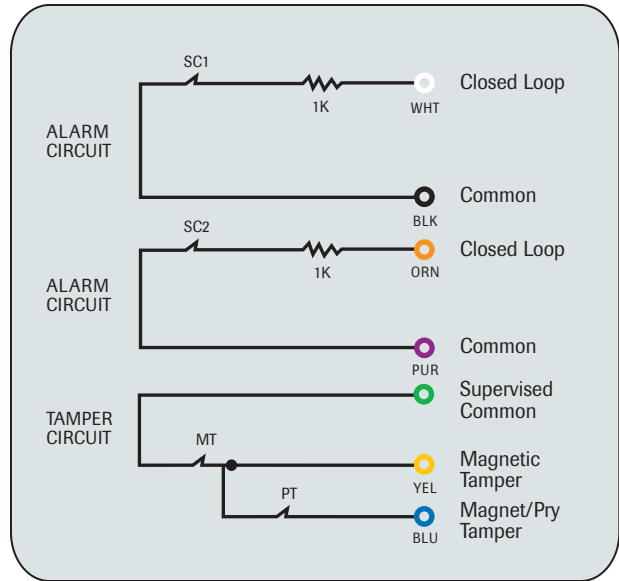

Model L2D-002

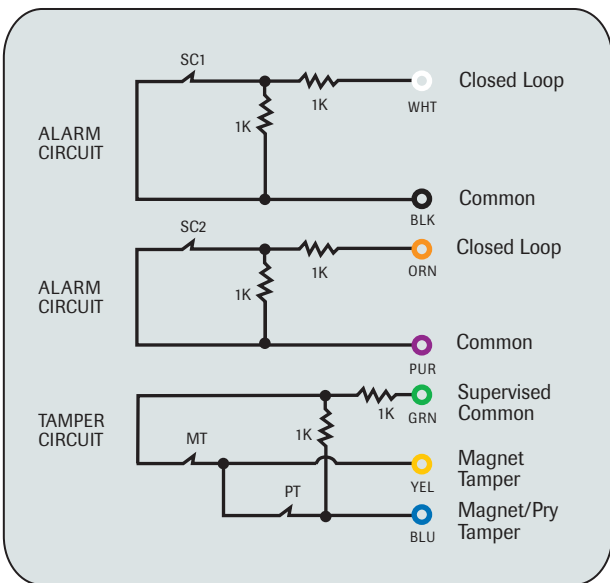

Model L2D-004

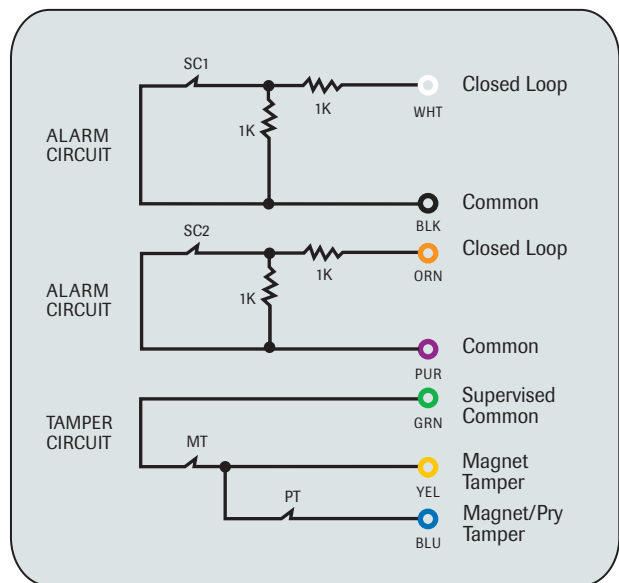



MAGNASPHERE[®] HSS[®]

The MAGNASPHERE HSS High Security Sensor conforms to the requirements of

UL Standard 913

Standard for Intrinsically Safe Apparatus and Associated Apparatus for Use in Class I, II, III, Division 1, Hazardous (Classified) Locations

for use in Hazardous locations as an INTRINSICALLY SAFE SIMPLE APPARATUS*.

INTRINSICALLY SAFE

The Construction of the HSS devices incorporates robust, hermetically sealed MAGNASPHERE switch technology, complete epoxy encapsulation of all electrical, components and magnetic actuation.

The MAGNASPHERE HSS models L2S and L2D used as intrinsically safe simple apparatus in hazardous locations MUST be used in conjunction with a Div. 1 Class 1 Group B Intrinsically Safe Barrier listed by a Nationally Recognized Testing Laboratory (NRTL).

The necessary consideration of the appropriate use of the apparatus in the hazardous locations is addressed in the instructions for the barrier (or device) providing power to this apparatus and to the hazardous location.



* Reference UL Standard 913 (includes UL 60079-11, the US adoption of the IEC 60079-11 standard for intrinsic safety, taking a national deviation [identified in the standards DV or DR] to correspond to the definition in the national electrical code). Sections: 3.1.1, 5.4 and associated DV and DR deviations.