

74HC373-Q100; 74HCT373-Q100

Octal D-type transparent latch; 3-state

Rev. 1 — 10 August 2012

Product data sheet

1. General description

The 74HC373-Q100; 74HCT373-Q100 is a high-speed Si-gate CMOS device and is pin compatible with Low-power Schottky TTL. It is specified in compliance with JEDEC standard no. 7A.

The 74HC373-Q100; 74HCT373-Q100 is an octal D-type transparent latch featuring separate D-type inputs for each latch and 3-state outputs for bus-oriented applications. A latch enable (LE) input and an output enable (\overline{OE}) input are common to all latches.

The 74HC373-Q100; 74HCT373-Q100 consists of eight D-type transparent latches with 3-state true outputs. When LE is HIGH, data at the Dn inputs enters the latches. In this condition the latches are transparent, i.e. a latch output changes state each time its corresponding D input changes.

When LE is LOW, the latches store the information that was present at the D inputs a set-up time preceding the HIGH-to-LOW transition of LE. When \overline{OE} is LOW, the contents of the 8 latches are available at the outputs. When \overline{OE} is HIGH, the outputs go to the high-impedance OFF-state. Operation of the \overline{OE} input does not affect the state of the latches.

The 74HC373-Q100; 74HCT373-Q100 is functionally identical to:

- 74HC573-Q100; 74HCT573-Q100: but different pin arrangement

This product has been qualified to the Automotive Electronics Council (AEC) standard Q100 (Grade 1) and is suitable for use in automotive applications.

2. Features and benefits

- Automotive product qualification in accordance with AEC-Q100 (Grade 1)
 - ◆ Specified from $-40\text{ }^{\circ}\text{C}$ to $+85\text{ }^{\circ}\text{C}$ and from $-40\text{ }^{\circ}\text{C}$ to $+125\text{ }^{\circ}\text{C}$
- Input levels:
 - ◆ For 74HC373-Q100: CMOS level
 - ◆ For 74HCT373-Q100: TTL level
- 3-state non-inverting outputs for bus-oriented applications
- Common 3-state output enable input
- Functionally identical to the 74HC573-Q100; 74HCT573-Q100
- ESD protection:
 - ◆ MIL-STD-883, method 3015 exceeds 2000 V
 - ◆ HBM JESD22-A114F exceeds 2000 V
 - ◆ MM JESD22-A115-A exceeds 200 V (C = 200 pF, R = 0 Ω)
- Multiple package options



3. Ordering information

Table 1. Ordering information

Type number	Package			Version
	Temperature range	Name	Description	
74HC373D-Q100 74HCT373D-Q100	-40 °C to +125 °C	SO20	plastic small outline package; 20 leads; body width 7.5 mm	SOT163-1
74HC373PW-Q100 74HCT373PW-Q100	-40 °C to +125 °C	TSSOP20	plastic thin shrink small outline package; 20 leads; body width 4.4 mm	SOT360-1
74HC373BQ-Q100 74HCT373BQ-Q100	-40 °C to +125 °C	DHVQFN20	plastic dual in-line compatible thermal enhanced very thin quad flat package; no leads; 20 terminals; body 2.5 × 4.5 × 0.85 mm	SOT764-1

4. Functional diagram

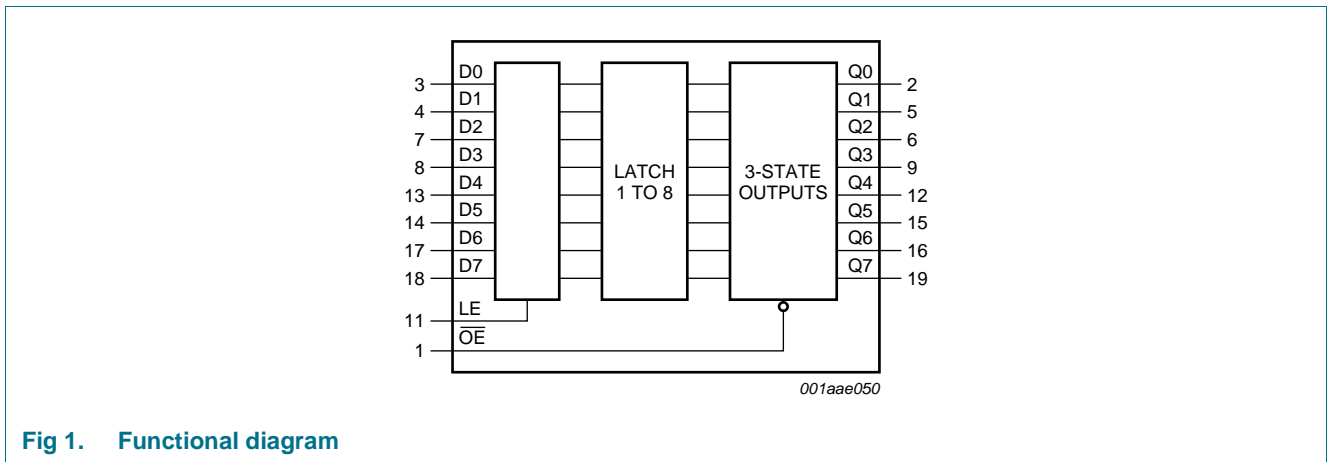

Fig 1. Functional diagram

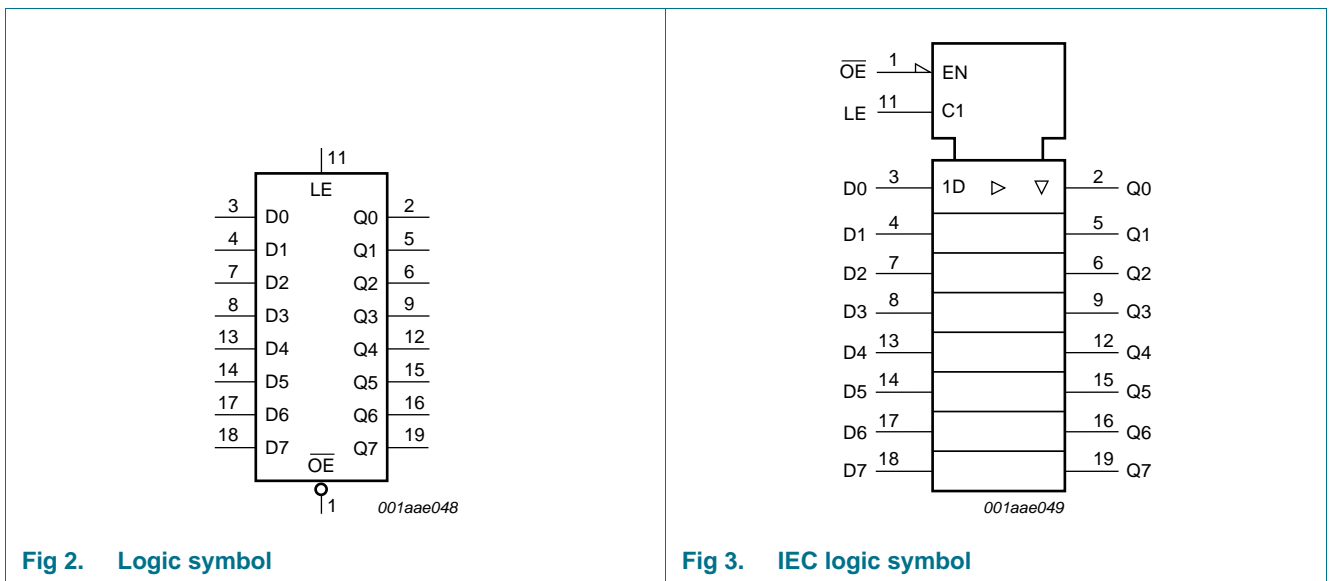
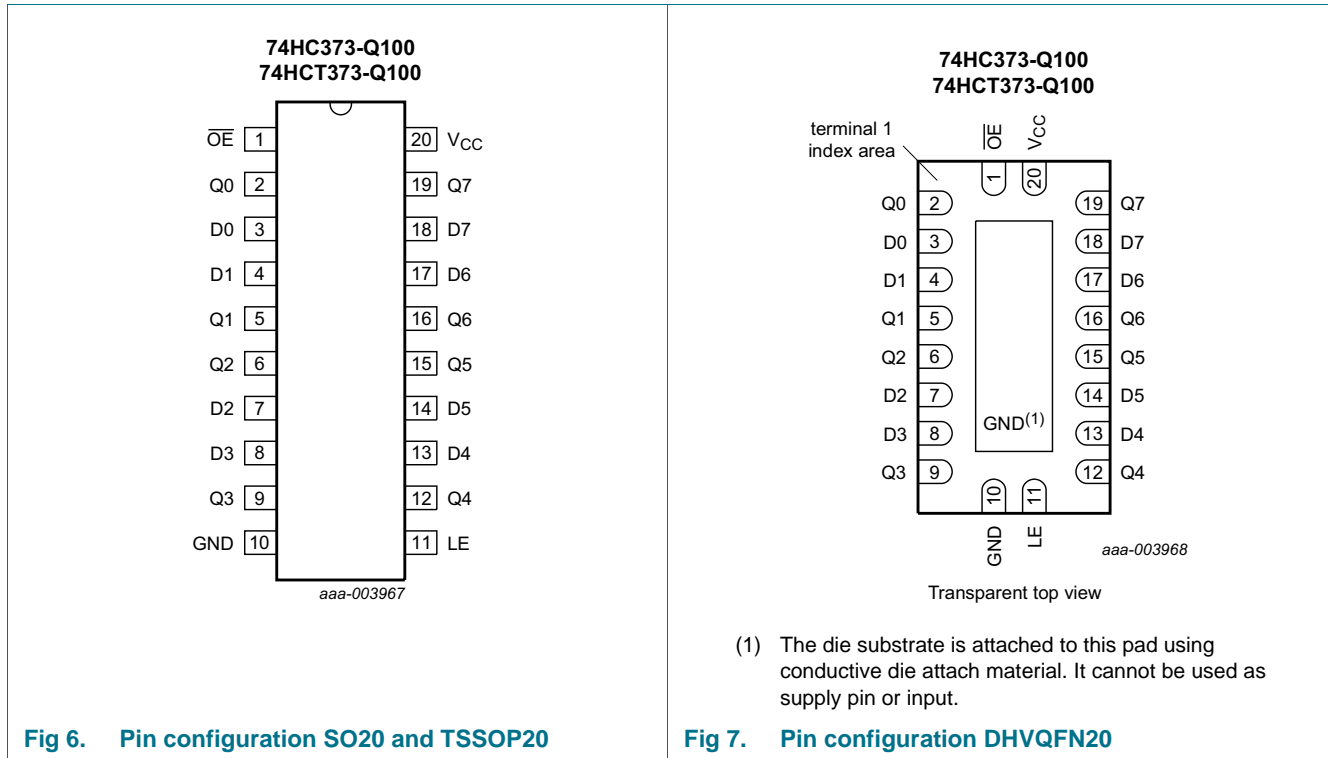

Fig 2. Logic symbol

Fig 3. IEC logic symbol

5. Pinning information

5.1 Pinning



5.2 Pin description

Table 2. Pin description

Symbol	Pin	Description
\overline{OE}	1	3-state output enable input (active LOW)
Q0, Q1, Q2, Q3, Q4, Q5, Q6, Q7	2, 5, 6, 9, 12, 15, 16, 19	3-state latch output
D0, D1, D2, D3, D4, D5, D6, D7	3, 4, 7, 8, 13, 14, 17, 18	data input
GND	10	ground (0 V)
LE	11	latch enable input (active HIGH)
V _{CC}	20	supply voltage

6. Functional description

6.1 Function table

Table 3. Function table^[1]

Operating mode	Control		Input	Internal latches	Output
	OE	LE	Dn		Qn
Enable and read register (transparent mode)	L	H	L	L	L
			H	H	H
Latch and read register	L	L	l	L	L
			h	H	H
Latch register and disable outputs	H	X	X	X	Z

- [1] H = HIGH voltage level;
 h = HIGH voltage level one set-up time prior to the HIGH-to-LOW LE transition;
 L = LOW voltage level;
 l = LOW voltage level one set-up time prior to the HIGH-to-LOW LE transition;
 X = don't care;
 Z = high-impedance OFF-state.

7. Limiting values

Table 4. Limiting values

In accordance with the Absolute Maximum Rating System (IEC 60134). Voltages are referenced to GND (ground = 0 V).

Symbol	Parameter	Conditions	Min	Max	Unit	
V _{CC}	supply voltage		-0.5	+7	V	
I _{IK}	input clamping current	V _I < -0.5 V or V _I > V _{CC} + 0.5 V	-	±20	mA	
I _{OK}	output clamping current	V _O < -0.5 V or V _O > V _{CC} + 0.5 V	-	±20	mA	
I _O	output current	V _O = -0.5 V to (V _{CC} + 0.5 V)	-	±35	mA	
I _{CC}	supply current		-	+70	mA	
I _{GND}	ground current		-	-70	mA	
T _{stg}	storage temperature		-65	+150	°C	
P _{tot}	total power dissipation	SO20 package	[1]	-	500	mW
		TSSOP20 package	[2]	-	500	mW
		DHVQFN20 package	[3]	-	500	mW

- [1] For SO20: P_{tot} derates linearly with 8 mW/K above 70 °C.
 [2] For TSSOP20 packages: P_{tot} derates linearly with 5.5 mW/K above 60 °C.
 [3] For DHVQFN20 package: P_{tot} derates linearly with 4.5 mW/K above 60 °C.

8. Recommended operating conditions

Table 5. Recommended operating conditions

Voltages are referenced to GND (ground = 0 V)

Symbol	Parameter	Conditions	74HC373-Q100			74HCT373-Q100			Unit
			Min	Typ	Max	Min	Typ	Max	
V _{CC}	supply voltage		2.0	5.0	6.0	4.5	5.0	5.5	V
V _I	input voltage		0	-	V _{CC}	0	-	V _{CC}	V
V _O	output voltage		0	-	V _{CC}	0	-	V _{CC}	V
T _{amb}	ambient temperature		-40	+25	+125	-40	+25	+125	°C
Δt/ΔV	input transition rise and fall rate	V _{CC} = 2.0 V	-	-	625	-	-	-	ns/V
		V _{CC} = 4.5 V	-	1.67	139	-	1.67	139	ns/V
		V _{CC} = 6.0 V	-	-	83	-	-	-	ns/V

9. Static characteristics

Table 6. Static characteristics 74HC373-Q100

At recommended operating conditions; voltages are referenced to GND (ground = 0 V).

Symbol	Parameter	Conditions	Min	Typ	Max	Unit
T_{amb} = 25 °C						
V _{IH}	HIGH-level input voltage	V _{CC} = 2.0 V	1.5	1.2	-	V
		V _{CC} = 4.5 V	3.15	2.4	-	V
		V _{CC} = 6.0 V	4.2	3.2	-	V
V _{IL}	LOW-level input voltage	V _{CC} = 2.0 V	-	0.8	0.5	V
		V _{CC} = 4.5 V	-	2.1	1.35	V
		V _{CC} = 6.0 V	-	2.8	1.8	V
V _{OH}	HIGH-level output voltage	V _I = V _{IH} or V _{IL}	-	-	-	
		I _O = -20 μA; V _{CC} = 2.0 V	1.9	2.0	-	V
		I _O = -20 μA; V _{CC} = 4.5 V	4.4	4.5	-	V
		I _O = -20 μA; V _{CC} = 6.0 V	5.9	6.0	-	V
		I _O = -6.0 mA; V _{CC} = 4.5 V	3.98	4.32	-	V
		I _O = -7.8 mA; V _{CC} = 6.0 V	5.48	5.81	-	V
V _{OL}	LOW-level output voltage	V _I = V _{IH} or V _{IL}	-	-	-	
		I _O = 20 μA; V _{CC} = 2.0 V	-	0	0.1	V
		I _O = 20 μA; V _{CC} = 4.5 V	-	0	0.1	V
		I _O = 20 μA; V _{CC} = 6.0 V	-	0	0.1	V
		I _O = 6.0 mA; V _{CC} = 4.5 V	-	0.15	0.26	V
		I _O = 7.8 mA; V _{CC} = 6.0 V	-	0.16	0.26	V
I _I	input leakage current	V _I = V _{CC} or GND; V _{CC} = 6.0 V	-	-	±0.1	μA
I _{OZ}	OFF-state output current	V _I = V _{IH} or V _{IL} ; V _{CC} = 6.0 V; V _O = V _{CC} or GND	-	-	±0.5	μA
I _{CC}	supply current	V _{CC} = 6.0 V; I _O = 0 A; V _I = V _{CC} or GND	-	-	8.0	μA
C _I	input capacitance		-	3.5	-	pF

Table 6. Static characteristics 74HC373-Q100 ...continued

At recommended operating conditions; voltages are referenced to GND (ground = 0 V).

Symbol	Parameter	Conditions	Min	Typ	Max	Unit
T_{amb} = -40 °C to +85 °C						
V _{IH}	HIGH-level input voltage	V _{CC} = 2.0 V	1.5	-	-	V
		V _{CC} = 4.5 V	3.15	-	-	V
		V _{CC} = 6.0 V	4.2	-	-	V
V _{IL}	LOW-level input voltage	V _{CC} = 2.0 V	-	-	0.5	V
		V _{CC} = 4.5 V	-	-	1.35	V
		V _{CC} = 6.0 V	-	-	1.8	V
V _{OH}	HIGH-level output voltage	V _I = V _{IH} or V _{IL}				
		I _O = -20 μA; V _{CC} = 2.0 V	1.9	-	-	V
		I _O = -20 μA; V _{CC} = 4.5 V	4.4	-	-	V
		I _O = -20 μA; V _{CC} = 6.0 V	5.9	-	-	V
		I _O = -6.0 mA; V _{CC} = 4.5 V	3.84	-	-	V
		I _O = -7.8 mA; V _{CC} = 6.0 V	5.34	-	-	V
V _{OL}	LOW-level output voltage	V _I = V _{IH} or V _{IL}				
		I _O = 20 μA; V _{CC} = 2.0 V	-	-	0.1	V
		I _O = 20 μA; V _{CC} = 4.5 V	-	-	0.1	V
		I _O = 20 μA; V _{CC} = 6.0 V	-	-	0.1	V
		I _O = 6.0 mA; V _{CC} = 4.5 V	-	-	0.33	V
		I _O = 7.8 mA; V _{CC} = 6.0 V	-	-	0.33	V
I _I	input leakage current	V _I = V _{CC} or GND; V _{CC} = 6.0 V	-	-	±1.0	μA
I _{oz}	OFF-state output current	V _I = V _{IH} or V _{IL} ; V _{CC} = 6.0 V; V _O = V _{CC} or GND	-	-	±5.0	μA
I _{CC}	supply current	V _{CC} = 6.0 V; I _O = 0 A; V _I = V _{CC} or GND		-	80	μA
T_{amb} = -40 °C to +125 °C						
V _{IH}	HIGH-level input voltage	V _{CC} = 2.0 V	1.5	-	-	V
		V _{CC} = 4.5 V	3.15	-	-	V
		V _{CC} = 6.0 V	4.2	-	-	V
V _{IL}	LOW-level input voltage	V _{CC} = 2.0 V	-	-	0.5	V
		V _{CC} = 4.5 V	-	-	1.35	V
		V _{CC} = 6.0 V	-	-	1.8	V
V _{OH}	HIGH-level output voltage	V _I = V _{IH} or V _{IL}				
		I _O = -20 μA; V _{CC} = 2.0 V	1.9	-	-	V
		I _O = -20 μA; V _{CC} = 4.5 V	4.4	-	-	V
		I _O = -20 μA; V _{CC} = 6.0 V	5.9	-	-	V
		I _O = -6.0 mA; V _{CC} = 4.5 V	3.7	-	-	V
		I _O = -7.8 mA; V _{CC} = 6.0 V	5.2	-	-	V

Table 6. Static characteristics 74HC373-Q100 ...continued

At recommended operating conditions; voltages are referenced to GND (ground = 0 V).

Symbol	Parameter	Conditions	Min	Typ	Max	Unit
V _{OL}	LOW-level output voltage	V _I = V _{IH} or V _{IL}				
		I _O = 20 μA; V _{CC} = 2.0 V	-	-	0.1	V
		I _O = 20 μA; V _{CC} = 4.5 V	-	-	0.1	V
		I _O = 20 μA; V _{CC} = 6.0 V	-	-	0.1	V
		I _O = 6.0 mA; V _{CC} = 4.5 V	-	-	0.4	V
		I _O = 7.8 mA; V _{CC} = 6.0 V	-	-	0.4	V
I _I	input leakage current	V _I = V _{CC} or GND; V _{CC} = 6.0 V	-	-	±1.0	μA
I _{OZ}	OFF-state output current	V _I = V _{IH} or V _{IL} ; V _{CC} = 6.0 V; V _O = V _{CC} or GND	-	-	±10.0	μA
I _{CC}	supply current	V _{CC} = 6.0 V; I _O = 0 A; V _I = V _{CC} or GND	-	-	160	μA

Table 7. Static characteristics 74HCT373-Q100

At recommended operating conditions; voltages are referenced to GND (ground = 0 V).

Symbol	Parameter	Conditions	Min	Typ	Max	Unit
T_{amb} = 25 °C						
V _{IH}	HIGH-level input voltage	V _{CC} = 4.5 V to 5.5 V	2.0	1.6	-	V
V _{IL}	LOW-level input voltage	V _{CC} = 4.5 V to 5.5 V	-	1.2	0.8	V
V _{OH}	HIGH-level output voltage	V _I = V _{IH} or V _{IL}				
		I _O = -20 μA; V _{CC} = 4.5 V	4.4	4.5	-	V
		I _O = -6.0 mA; V _{CC} = 4.5 V	3.98	4.32	-	V
V _{OL}	LOW-level output voltage	V _I = V _{IH} or V _{IL}				
		I _O = 20 μA; V _{CC} = 4.5 V	-	0.0	0.1	V
		I _O = 6.0 mA; V _{CC} = 4.5 V	-	0.16	0.26	V
I _I	input leakage current	V _I = V _{CC} or GND; V _{CC} = 5.5 V	-	-	±0.1	μA
I _{OZ}	OFF-state output current	V _I = V _{IH} or V _{IL} ; V _{CC} = 5.5 V; V _O = V _{CC} or GND per input pin; other inputs at V _{CC} or GND; I _O = 0 A	-	-	±0.5	μA
I _{CC}	supply current	V _I = V _{CC} or GND; I _O = 0 A; V _{CC} = 5.5 V	-	-	8.0	μA
ΔI _{CC}	additional supply current	V _I = V _{CC} - 2.1 V; other inputs at V _{CC} or GND; V _{CC} = 4.5 V to 5.5 V; I _O = 0 A				
		Dn	-	30	108	μA
		LE	-	150	540	μA
		$\overline{\text{OE}}$	-	100	360	μA
C _I	input capacitance		-	3.5	-	pF
T_{amb} = -40 °C to +85 °C						
V _{IH}	HIGH-level input voltage	V _{CC} = 4.5 V to 5.5 V	2.0	-	-	V
V _{IL}	LOW-level input voltage	V _{CC} = 4.5 V to 5.5 V	-	-	0.8	V

Table 7. Static characteristics 74HCT373-Q100 ...continued

At recommended operating conditions; voltages are referenced to GND (ground = 0 V).

Symbol	Parameter	Conditions	Min	Typ	Max	Unit
V _{OH}	HIGH-level output voltage	V _I = V _{IH} or V _{IL}				
		I _O = -20 μA; V _{CC} = 4.5 V	4.4	-	-	V
		I _O = -6.0 μA; V _{CC} = 4.5 V	3.84	-	-	V
V _{OL}	LOW-level output voltage	V _I = V _{IH} or V _{IL}				
		I _O = 20 μA; V _{CC} = 4.5 V	-	-	0.1	V
		I _O = 6.0 mA; V _{CC} = 4.5 V	-	-	0.33	V
I _I	input leakage current	V _I = V _{CC} or GND; V _{CC} = 5.5 V	-	-	±1.0	μA
I _{OZ}	OFF-state output current	V _I = V _{IH} or V _{IL} ; V _{CC} = 5.5 V; V _O = V _{CC} or GND per input pin; other inputs at V _{CC} or GND; I _O = 0 A	-	-	±5.0	μA
I _{CC}	supply current	V _I = V _{CC} or GND; I _O = 0 A; V _{CC} = 5.5 V	-	-	80	μA
ΔI _{CC}	additional supply current	V _I = V _{CC} - 2.1 V; other inputs at V _{CC} or GND; V _{CC} = 4.5 V to 5.5 V; I _O = 0 A				
		Dn	-	-	135	μA
		LE	-	-	675	μA
		$\overline{\text{OE}}$	-	-	450	μA
T_{amb} = -40 °C to +125 °C						
V _{IH}	HIGH-level input voltage	V _{CC} = 4.5 V to 5.5 V	2.0	-	-	V
V _{IL}	LOW-level input voltage	V _{CC} = 4.5 V to 5.5 V	-	-	0.8	V
V _{OH}	HIGH-level output voltage	V _I = V _{IH} or V _{IL}				
		I _O = -20 μA; V _{CC} = 4.5 V	4.4	-	-	V
		I _O = -6.0 mA; V _{CC} = 4.5 V	3.7	-	-	V
V _{OL}	LOW-level output voltage	V _I = V _{IH} or V _{IL}				
		I _O = 20 μA; V _{CC} = 4.5 V	-	-	0.1	V
		I _O = 6.0 mA; V _{CC} = 4.5 V	-	-	0.4	V
I _I	input leakage current	V _I = V _{CC} or GND; V _{CC} = 5.5 V	-	-	±1.0	μA
I _{OZ}	OFF-state output current	V _I = V _{IH} or V _{IL} ; V _{CC} = 5.5 V; V _O = V _{CC} or GND per input pin; other inputs at V _{CC} or GND; I _O = 0 A	-	-	±10	μA
I _{CC}	supply current	V _I = V _{CC} or GND; I _O = 0 A; V _{CC} = 5.5 V	-	-	160	μA
ΔI _{CC}	additional supply current	V _I = V _{CC} - 2.1 V; other inputs at V _{CC} or GND; V _{CC} = 4.5 V to 5.5 V; I _O = 0 A				
		Dn	-	-	147	μA
		LE	-	-	735	μA
		$\overline{\text{OE}}$	-	-	490	μA

10. Dynamic characteristics

Table 8. Dynamic characteristics 74HC373-Q100

Voltages are referenced to GND (ground = 0 V); $C_L = 50$ pF unless otherwise specified; for test circuit see [Figure 12](#).

Symbol	Parameter	Conditions	Min	Typ	Max	Unit	
$T_{amb} = 25$ °C							
t_{pd}	propagation delay	Dn to Qn; see Figure 8	[1]				
		$V_{CC} = 2.0$ V	-	41	150	ns	
		$V_{CC} = 4.5$ V	-	15	30	ns	
		$V_{CC} = 5$ V; $C_L = 15$ pF	-	12	-	ns	
		$V_{CC} = 6.0$ V	-	12	26	ns	
		LE to Qn; see Figure 9					
		$V_{CC} = 2.0$ V	-	50	175	ns	
		$V_{CC} = 4.5$ V	-	18	35	ns	
		$V_{CC} = 5$ V; $C_L = 15$ pF	-	15	-	ns	
$V_{CC} = 6.0$ V	-	14	30	ns			
t_{en}	enable time	\overline{OE} to Qn; see Figure 10	[2]				
		$V_{CC} = 2.0$ V	-	44	150	ns	
		$V_{CC} = 4.5$ V	-	16	30	ns	
		$V_{CC} = 6.0$ V	-	13	26	ns	
t_{dis}	disable time	\overline{OE} to Qn; see Figure 10	[3]				
		$V_{CC} = 2.0$ V	-	47	150	ns	
		$V_{CC} = 4.5$ V	-	17	30	ns	
		$V_{CC} = 6.0$ V	-	14	26	ns	
t_t	transition time	Qn; see Figure 8 and Figure 9	[4]				
		$V_{CC} = 2.0$ V	-	14	60	ns	
		$V_{CC} = 4.5$ V	-	5	12	ns	
		$V_{CC} = 6.0$ V	-	4	10	ns	
t_W	pulse width	LE HIGH; see Figure 9					
		$V_{CC} = 2.0$ V	80	17	-	ns	
		$V_{CC} = 4.5$ V	16	6	-	ns	
		$V_{CC} = 6.0$ V	14	5	-	ns	
t_{su}	set-up time	Dn to LE; see Figure 11					
		$V_{CC} = 2.0$ V	50	14	-	ns	
		$V_{CC} = 4.5$ V	10	5	-	ns	
		$V_{CC} = 6.0$ V	9	4	-	ns	
t_h	hold time	Dn to LE; see Figure 11					
		$V_{CC} = 2.0$ V	+5	-8	-	ns	
		$V_{CC} = 4.5$ V	+5	-3	-	ns	
		$V_{CC} = 6.0$ V	+5	-2	-	ns	
C_{PD}	power dissipation capacitance	per latch; $V_I = GND$ to V_{CC}	[5]	-	45	-	pF

Table 8. Dynamic characteristics 74HC373-Q100 ...continued

Voltages are referenced to GND (ground = 0 V); $C_L = 50$ pF unless otherwise specified; for test circuit see [Figure 12](#).

Symbol	Parameter	Conditions	Min	Typ	Max	Unit
$T_{amb} = -40$ °C to $+85$ °C						
t_{pd}	propagation delay	Dn to Qn; see Figure 8				[1]
		$V_{CC} = 2.0$ V	-	-	190	ns
		$V_{CC} = 4.5$ V	-	-	38	ns
		$V_{CC} = 6.0$ V	-	-	33	ns
		LE to Qn; see Figure 9				
		$V_{CC} = 2.0$ V	-	-	220	ns
		$V_{CC} = 4.5$ V	-	-	44	ns
		$V_{CC} = 6.0$ V	-	-	37	ns
		t_{en}	enable time	\overline{OE} to Qn; see Figure 10		
$V_{CC} = 2.0$ V	-			-	190	ns
$V_{CC} = 4.5$ V	-			-	38	ns
$V_{CC} = 6.0$ V	-			-	33	ns
t_{dis}	disable time	\overline{OE} to Qn; see Figure 10				[3]
		$V_{CC} = 2.0$ V	-	-	190	ns
		$V_{CC} = 4.5$ V	-	-	38	ns
		$V_{CC} = 6.0$ V	-	-	33	ns
t_t	transition time	Qn; see Figure 8 and Figure 9				[4]
		$V_{CC} = 2.0$ V	-	-	75	ns
		$V_{CC} = 4.5$ V	-	-	15	ns
		$V_{CC} = 6.0$ V	-	-	13	ns
t_W	pulse width	LE HIGH; see Figure 9				
		$V_{CC} = 2.0$ V	100	-	-	ns
		$V_{CC} = 4.5$ V	20	-	-	ns
		$V_{CC} = 6.0$ V	17	-	-	ns
t_{su}	set-up time	Dn to LE; see Figure 11				
		$V_{CC} = 2.0$ V	65	-	-	ns
		$V_{CC} = 4.5$ V	13	-	-	ns
		$V_{CC} = 6.0$ V	11	-	-	ns
t_h	hold time	Dn to LE; see Figure 11				
		$V_{CC} = 2.0$ V	5	-	-	ns
		$V_{CC} = 4.5$ V	5	-	-	ns
		$V_{CC} = 6.0$ V	5	-	-	ns

Table 8. Dynamic characteristics 74HC373-Q100 ...continued

Voltages are referenced to GND (ground = 0 V); $C_L = 50$ pF unless otherwise specified; for test circuit see [Figure 12](#).

Symbol	Parameter	Conditions	Min	Typ	Max	Unit
$T_{amb} = -40$ °C to $+125$ °C						
t_{pd}	propagation delay	Dn to Qn; see Figure 8	[1]			
		$V_{CC} = 2.0$ V	-	-	225	ns
		$V_{CC} = 4.5$ V	-	-	45	ns
		$V_{CC} = 6.0$ V	-	-	38	ns
		LE to Qn; see Figure 9				
		$V_{CC} = 2.0$ V	-	-	265	ns
		$V_{CC} = 4.5$ V	-	-	53	ns
		$V_{CC} = 6.0$ V	-	-	45	ns
		t_{en}	enable time	\overline{OE} to Qn; see Figure 10	[2]	
$V_{CC} = 2.0$ V	-			-	225	ns
$V_{CC} = 4.5$ V	-			-	45	ns
$V_{CC} = 6.0$ V	-			-	38	ns
t_{dis}	disable time	\overline{OE} to Qn; see Figure 10	[3]			
		$V_{CC} = 2.0$ V	-	-	225	ns
		$V_{CC} = 4.5$ V	-	-	45	ns
		$V_{CC} = 6.0$ V	-	-	38	ns
t_t	transition time	Qn; see Figure 8 and Figure 9	[4]			
		$V_{CC} = 2.0$ V	-	-	90	ns
		$V_{CC} = 4.5$ V	-	-	18	ns
		$V_{CC} = 6.0$ V	-	-	15	ns
t_W	pulse width	LE HIGH; see Figure 9				
		$V_{CC} = 2.0$ V	120	-	-	ns
		$V_{CC} = 4.5$ V	24	-	-	ns
		$V_{CC} = 6.0$ V	20	-	-	ns
t_{su}	set-up time	Dn to LE; see Figure 11				
		$V_{CC} = 2.0$ V	75	-	-	ns
		$V_{CC} = 4.5$ V	15	-	-	ns
		$V_{CC} = 6.0$ V	13	-	-	ns

Table 8. Dynamic characteristics 74HC373-Q100 ...continued

Voltages are referenced to GND (ground = 0 V); $C_L = 50$ pF unless otherwise specified; for test circuit see [Figure 12](#).

Symbol	Parameter	Conditions	Min	Typ	Max	Unit
t_h	hold time	Dn to LE; see Figure 11				
		$V_{CC} = 2.0$ V	5	-	-	ns
		$V_{CC} = 4.5$ V	5	-	-	ns
		$V_{CC} = 6.0$ V	5	-	-	ns

[1] t_{pd} is the same as t_{PLH} and t_{PHL} .

[2] t_{en} is the same as t_{PZH} and t_{PZL} .

[3] t_{dis} is the same as t_{PLZ} and t_{PHZ} .

[4] t_t is the same as t_{THL} and t_{TLH} .

[5] C_{PD} is used to determine the dynamic power dissipation (P_D in μ W).

$P_D = C_{PD} \times V_{CC}^2 \times f_i \times N + \Sigma(C_L \times V_{CC}^2 \times f_o)$ where:

f_i = input frequency in MHz;

f_o = output frequency in MHz;

C_L = output load capacitance in pF;

V_{CC} = supply voltage in V;

N = number of inputs switching;

$\Sigma(C_L \times V_{CC}^2 \times f_o)$ = sum of outputs.

Table 9. Dynamic characteristics 74HCT373-Q100

Voltages are referenced to GND (ground = 0 V); $C_L = 50$ pF unless otherwise specified; for test circuit see [Figure 12](#).

Symbol	Parameter	Conditions	Min	Typ	Max	Unit	
$T_{amb} = 25$ °C							
t_{pd}	propagation delay	Dn to Qn; see Figure 8	[1]				
		$V_{CC} = 4.5$ V	-	17	30	ns	
		$V_{CC} = 5$ V; $C_L = 15$ pF	-	14	-	ns	
		LE to Qn; see Figure 9					
		$V_{CC} = 4.5$ V	-	16	32	ns	
		$V_{CC} = 5$ V; $C_L = 15$ pF	-	13	-	ns	
t_{en}	enable time	\overline{OE} to Qn; see Figure 10	[2]				
		$V_{CC} = 4.5$ V	-	19	32	ns	
t_{dis}	disable time	\overline{OE} to Qn; see Figure 10	[3]				
		$V_{CC} = 4.5$ V	-	18	30	ns	
t_t	transition time	Qn; see Figure 8 and Figure 9	[4]				
		$V_{CC} = 4.5$ V	-	5	12	ns	
t_W	pulse width	LE HIGH; see Figure 9					
		$V_{CC} = 4.5$ V	16	4	-	ns	
t_{su}	set-up time	Dn to LE; see Figure 11					
		$V_{CC} = 4.5$ V	12	6	-	ns	
t_h	hold time	Dn to LE; see Figure 11					
		$V_{CC} = 4.5$ V	4	-1	-	ns	
C_{PD}	power dissipation capacitance	per latch; $V_1 = GND$ to ($V_{CC} - 1.5$ V)	[5]	-	41	-	pF

Table 9. Dynamic characteristics 74HCT373-Q100 ...continued

Voltages are referenced to GND (ground = 0 V); $C_L = 50$ pF unless otherwise specified; for test circuit see [Figure 12](#).

Symbol	Parameter	Conditions	Min	Typ	Max	Unit
$T_{amb} = -40$ °C to $+85$ °C						
t_{pd}	propagation delay	Dn to Qn; see Figure 8	[1]			
		$V_{CC} = 4.5$ V	-	-	38	ns
		LE to Qn; see Figure 9				
		$V_{CC} = 4.5$ V	-	-	40	ns
t_{en}	enable time	\overline{OE} to Qn; see Figure 10	[2]			
		$V_{CC} = 4.5$ V	-	-	40	ns
t_{dis}	disable time	\overline{OE} to Qn; see Figure 10	[3]			
		$V_{CC} = 4.5$ V	-	-	38	ns
t_t	transition time	Qn; see Figure 8 and Figure 9	[4]			
		$V_{CC} = 4.5$ V	-	-	15	ns
t_W	pulse width	LE HIGH; see Figure 9				
		$V_{CC} = 4.5$ V	20	-	-	ns
t_{su}	set-up time	Dn to LE; see Figure 11				
		$V_{CC} = 4.5$ V	15	-	-	ns
t_h	hold time	Dn to LE; see Figure 11				
		$V_{CC} = 4.5$ V	4	-	-	ns
$T_{amb} = -40$ °C to $+125$ °C						
t_{pd}	propagation delay	Dn to Qn; see Figure 8	[1]			
		$V_{CC} = 4.5$ V	-	-	45	ns
		LE to Qn; see Figure 9				
		$V_{CC} = 4.5$ V	-	-	48	ns
t_{en}	enable time	\overline{OE} to Qn; see Figure 10	[2]			
		$V_{CC} = 4.5$ V	-	-	48	ns
t_{dis}	disable time	\overline{OE} to Qn; see Figure 10	[3]			
		$V_{CC} = 4.5$ V	-	-	45	ns
t_t	transition time	Qn; see Figure 8 and Figure 9	[4]			
		$V_{CC} = 4.5$ V	-	-	18	ns
t_W	pulse width	LE HIGH; see Figure 9				
		$V_{CC} = 4.5$ V	24	-	-	ns
t_{su}	set-up time Dn to LE	Dn to LE; see Figure 11				
		$V_{CC} = 4.5$ V	18	-	-	ns

Table 9. Dynamic characteristics 74HCT373-Q100 ...continued

Voltages are referenced to GND (ground = 0 V); $C_L = 50 \text{ pF}$ unless otherwise specified; for test circuit see [Figure 12](#).

Symbol	Parameter	Conditions	Min	Typ	Max	Unit
t_h	hold time Dn to LE	Dn to LE; see Figure 11 $V_{CC} = 4.5 \text{ V}$	4	-	-	ns

- [1] t_{pd} is the same as t_{PLH} and t_{PHL} .
- [2] t_{en} is the same as t_{PZH} and t_{PZL} .
- [3] t_{dis} is the same as t_{PLZ} and t_{PHZ} .
- [4] t_i is the same as t_{THL} and t_{TLH} .
- [5] C_{PD} is used to determine the dynamic power dissipation (P_D in μW).
 $P_D = C_{PD} \times V_{CC}^2 \times f_i \times N + \sum(C_L \times V_{CC}^2 \times f_o)$ where:
 f_i = input frequency in MHz;
 f_o = output frequency in MHz;
 C_L = output load capacitance in pF;
 V_{CC} = supply voltage in V;
 N = number of inputs switching;
 $\sum(C_L \times V_{CC}^2 \times f_o)$ = sum of outputs.

11. Waveforms

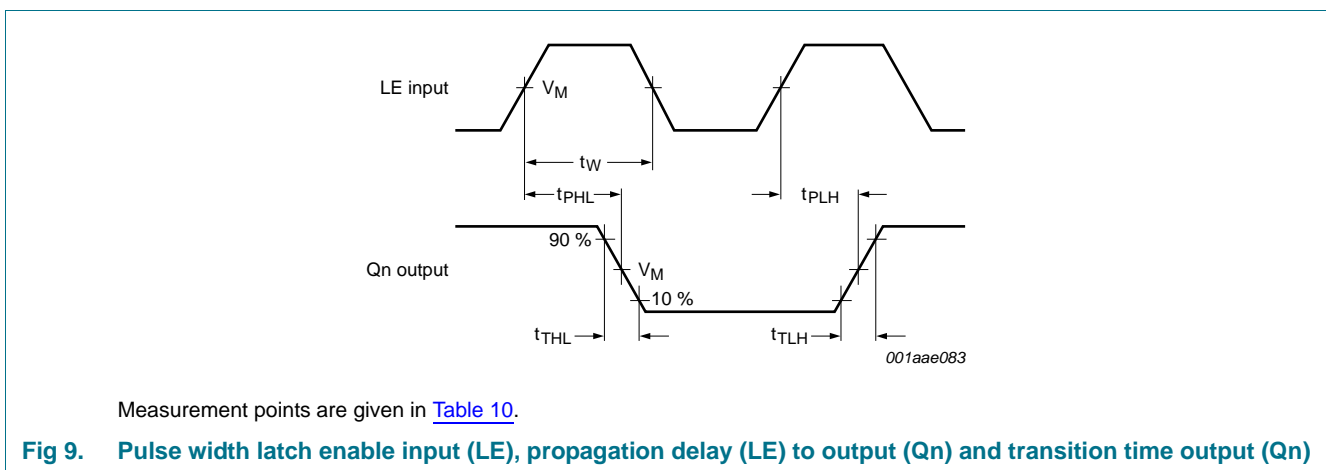
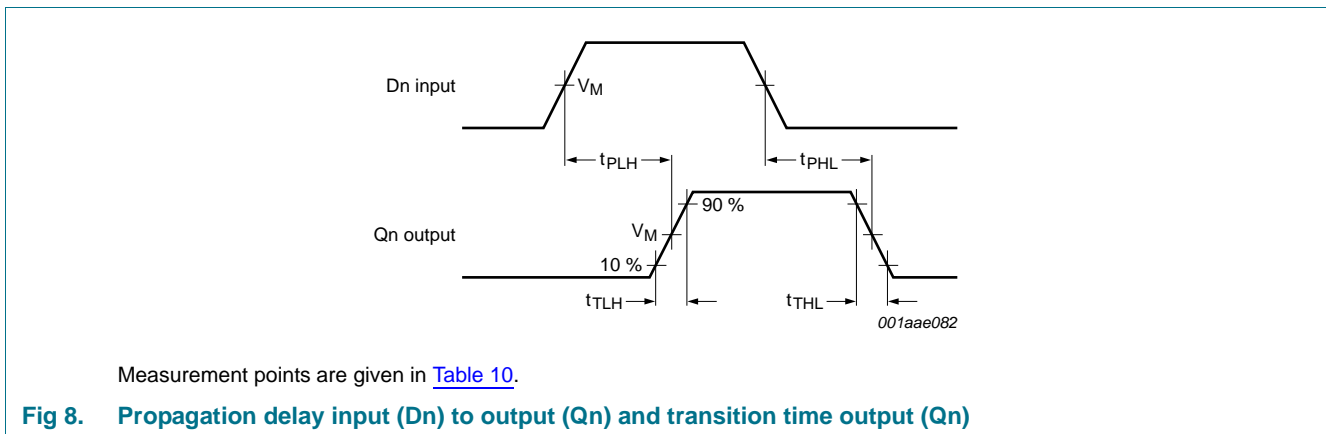

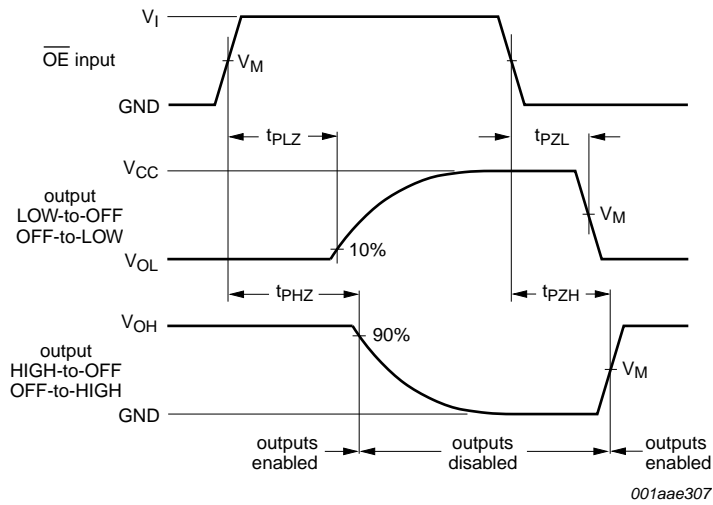

Measurement points are given in [Table 10](#).

Fig 10. 3-state enable and disable time

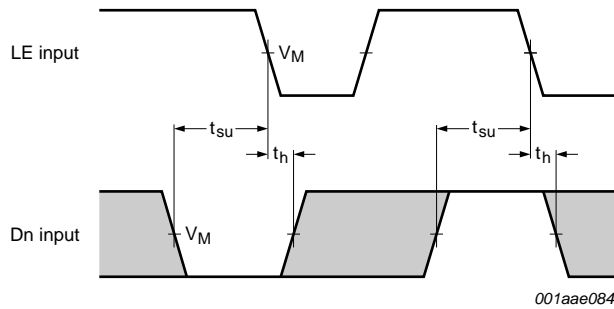

Measurement points are given in [Table 10](#).

Fig 11. Set-up and hold time data input (Dn) to latch enable input (LE)

Table 10. Measurement points

Type	Input	Output
	V_M	V_M
74HC373-Q100	$0.5V_{CC}$	$0.5V_{CC}$
74HCT373-Q100	1.3 V	1.3 V

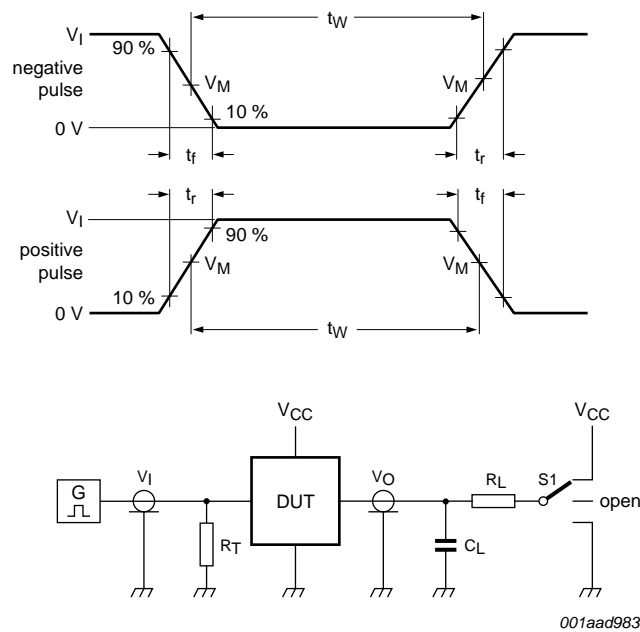

001aad983

Test data is given in [Table 11](#).

Definitions test circuit:

R_T = Termination resistance should be equal to output impedance Z_o of the pulse generator

C_L = Load capacitance including jig and probe capacitance

R_L = Load resistor

S1 = Test selection switch

Fig 12. Test circuit for measuring switching times

Table 11. Test data

Type	Input		Load		S1 position		
	V_I	t_r, t_f	C_L	R_L	t_{PHL}, t_{PLH}	t_{PZH}, t_{PHZ}	t_{PZL}, t_{PLZ}
74HC373-Q100	V_{CC}	6 ns	15 pF, 50 pF	1 k Ω	open	GND	V_{CC}
74HCT373-Q100	3 V	6 ns	15 pF, 50 pF	1 k Ω	open	GND	V_{CC}

12. Package outline

SO20: plastic small outline package; 20 leads; body width 7.5 mm

SOT163-1

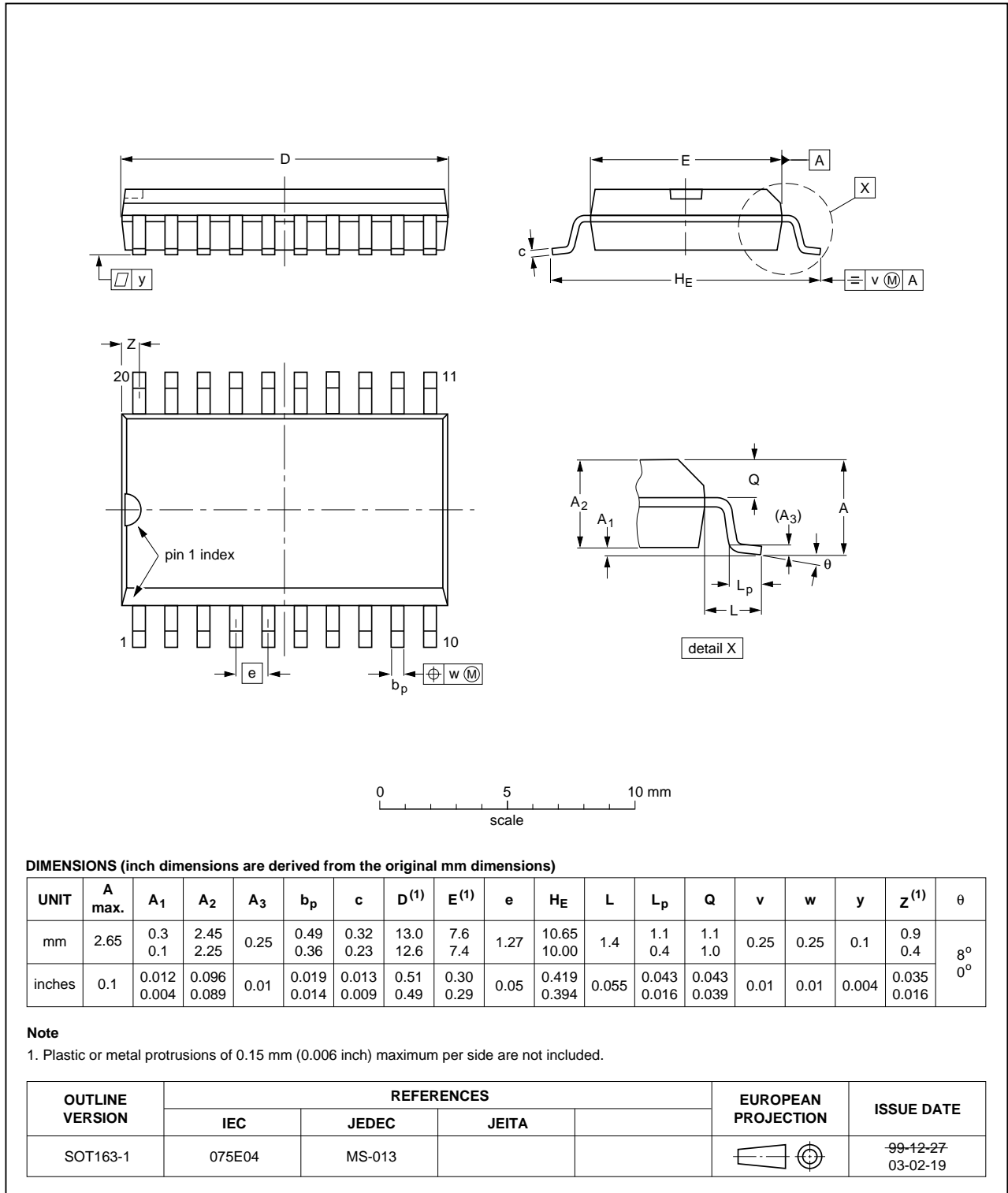

Fig 13. Package outline SOT163-1 (SO20)

TSSOP20: plastic thin shrink small outline package; 20 leads; body width 4.4 mm

SOT360-1

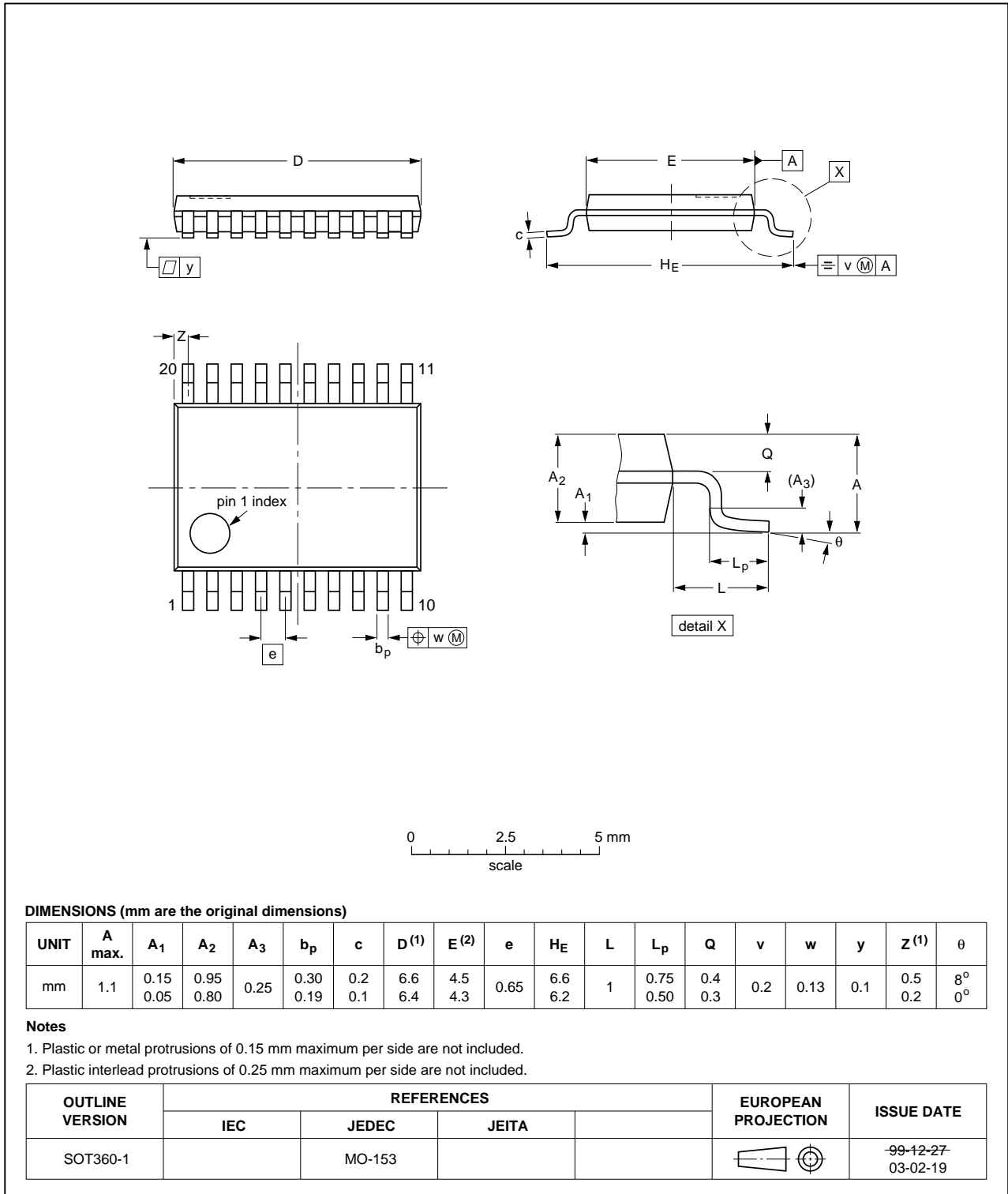

Fig 14. Package outline SOT360-1 (TSSOP20)

DHVQFN20: plastic dual in-line compatible thermal enhanced very thin quad flat package; no leads; 20 terminals; body 2.5 x 4.5 x 0.85 mm

SOT764-1

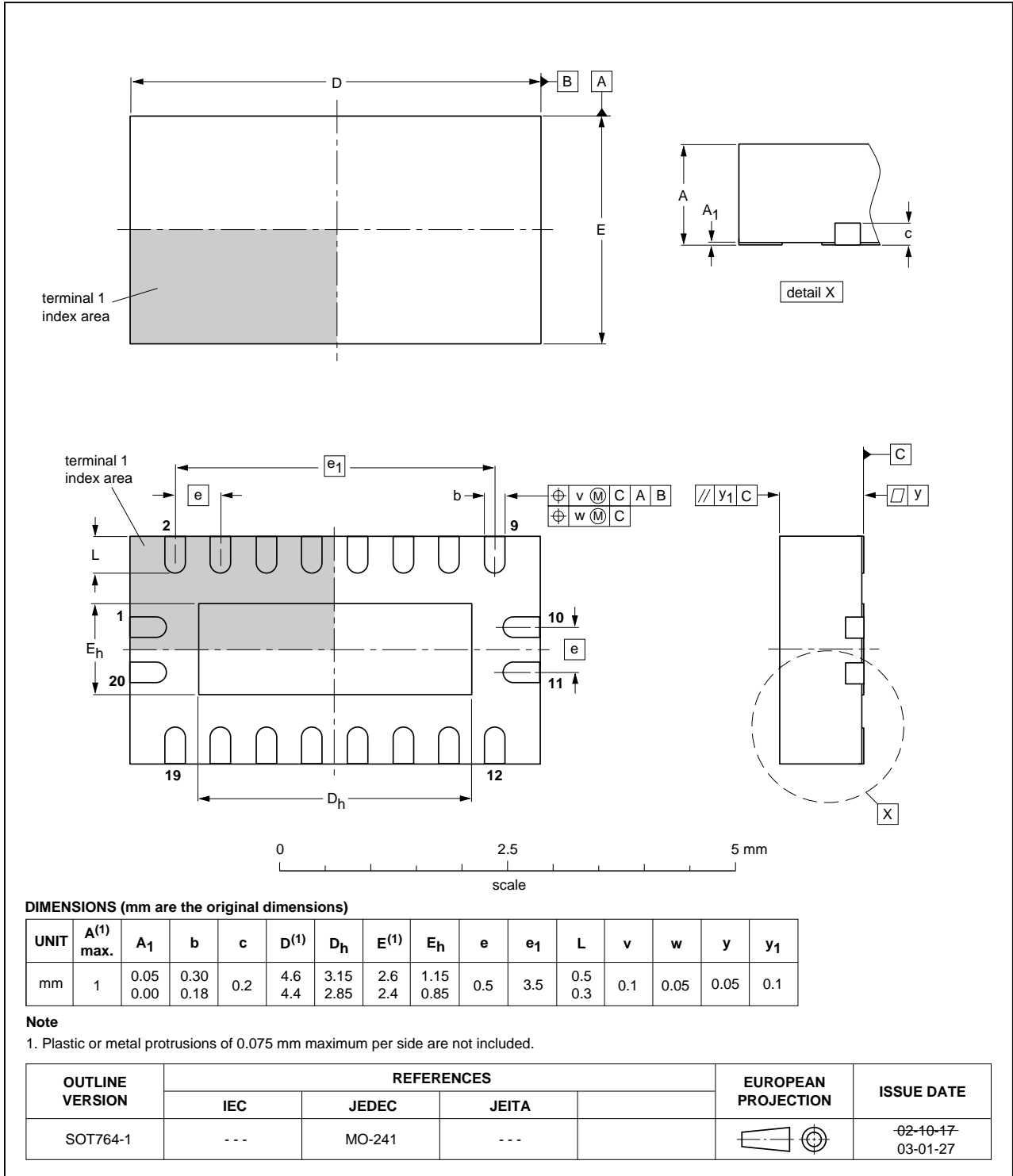

Fig 15. Package outline SOT764-1 (DHVQFN20)

13. Abbreviations

Table 12. Abbreviations

Acronym	Description
CMOS	Complementary Metal Oxide Semiconductor
ESD	ElectroStatic Discharge
HBM	Human Body Model
MM	Machine Model
TTL	Transistor-Transistor Logic
MIL	Military

14. Revision history

Table 13. Revision history

Document ID	Release date	Data sheet status	Change notice	Supersedes
74HC_HCT373_Q100 v.1	20120810	Product data sheet	-	-

15. Legal information

15.1 Data sheet status

Document status ^{[1][2]}	Product status ^[3]	Definition
Objective [short] data sheet	Development	This document contains data from the objective specification for product development.
Preliminary [short] data sheet	Qualification	This document contains data from the preliminary specification.
Product [short] data sheet	Production	This document contains the product specification.

[1] Please consult the most recently issued document before initiating or completing a design.

[2] The term 'short data sheet' is explained in section "Definitions".

[3] The product status of device(s) described in this document may have changed since this document was published and may differ in case of multiple devices. The latest product status information is available on the Internet at URL <http://www.nxp.com>.

15.2 Definitions

Draft — The document is a draft version only. The content is still under internal review and subject to formal approval, which may result in modifications or additions. NXP Semiconductors does not give any representations or warranties as to the accuracy or completeness of information included herein and shall have no liability for the consequences of use of such information.

Short data sheet — A short data sheet is an extract from a full data sheet with the same product type number(s) and title. A short data sheet is intended for quick reference only and should not be relied upon to contain detailed and full information. For detailed and full information see the relevant full data sheet, which is available on request via the local NXP Semiconductors sales office. In case of any inconsistency or conflict with the short data sheet, the full data sheet shall prevail.

Product specification — The information and data provided in a Product data sheet shall define the specification of the product as agreed between NXP Semiconductors and its customer, unless NXP Semiconductors and customer have explicitly agreed otherwise in writing. In no event however, shall an agreement be valid in which the NXP Semiconductors product is deemed to offer functions and qualities beyond those described in the Product data sheet.

15.3 Disclaimers

Limited warranty and liability — Information in this document is believed to be accurate and reliable. However, NXP Semiconductors does not give any representations or warranties, expressed or implied, as to the accuracy or completeness of such information and shall have no liability for the consequences of use of such information. NXP Semiconductors takes no responsibility for the content in this document if provided by an information source outside of NXP Semiconductors.

In no event shall NXP Semiconductors be liable for any indirect, incidental, punitive, special or consequential damages (including - without limitation - lost profits, lost savings, business interruption, costs related to the removal or replacement of any products or rework charges) whether or not such damages are based on tort (including negligence), warranty, breach of contract or any other legal theory.

Notwithstanding any damages that customer might incur for any reason whatsoever, NXP Semiconductors' aggregate and cumulative liability towards customer for the products described herein shall be limited in accordance with the *Terms and conditions of commercial sale* of NXP Semiconductors.

Right to make changes — NXP Semiconductors reserves the right to make changes to information published in this document, including without limitation specifications and product descriptions, at any time and without notice. This document supersedes and replaces all information supplied prior to the publication hereof.

Suitability for use in automotive applications — This NXP Semiconductors product has been qualified for use in automotive applications. Unless otherwise agreed in writing, the product is not designed, authorized or warranted to be suitable for use in life support, life-critical or safety-critical systems or equipment, nor in applications where failure or malfunction of an NXP Semiconductors product can reasonably be expected to result in personal injury, death or severe property or environmental damage. NXP Semiconductors and its suppliers accept no liability for inclusion and/or use of NXP Semiconductors products in such equipment or applications and therefore such inclusion and/or use is at the customer's own risk.

Applications — Applications that are described herein for any of these products are for illustrative purposes only. NXP Semiconductors makes no representation or warranty that such applications will be suitable for the specified use without further testing or modification.

Customers are responsible for the design and operation of their applications and products using NXP Semiconductors products, and NXP Semiconductors accepts no liability for any assistance with applications or customer product design. It is customer's sole responsibility to determine whether the NXP Semiconductors product is suitable and fit for the customer's applications and products planned, as well as for the planned application and use of customer's third party customer(s). Customers should provide appropriate design and operating safeguards to minimize the risks associated with their applications and products.

NXP Semiconductors does not accept any liability related to any default, damage, costs or problem which is based on any weakness or default in the customer's applications or products, or the application or use by customer's third party customer(s). Customer is responsible for doing all necessary testing for the customer's applications and products using NXP Semiconductors products in order to avoid a default of the applications and the products or of the application or use by customer's third party customer(s). NXP does not accept any liability in this respect.

Limiting values — Stress above one or more limiting values (as defined in the Absolute Maximum Ratings System of IEC 60134) will cause permanent damage to the device. Limiting values are stress ratings only and (proper) operation of the device at these or any other conditions above those given in the Recommended operating conditions section (if present) or the Characteristics sections of this document is not warranted. Constant or repeated exposure to limiting values will permanently and irreversibly affect the quality and reliability of the device.

Terms and conditions of commercial sale — NXP Semiconductors products are sold subject to the general terms and conditions of commercial sale, as published at <http://www.nxp.com/profile/terms>, unless otherwise agreed in a valid written individual agreement. In case an individual agreement is concluded only the terms and conditions of the respective agreement shall apply. NXP Semiconductors hereby expressly objects to applying the customer's general terms and conditions with regard to the purchase of NXP Semiconductors products by customer.

No offer to sell or license — Nothing in this document may be interpreted or construed as an offer to sell products that is open for acceptance or the grant, conveyance or implication of any license under any copyrights, patents or other industrial or intellectual property rights.

Export control — This document as well as the item(s) described herein may be subject to export control regulations. Export might require a prior authorization from competent authorities.

Translations — A non-English (translated) version of a document is for reference only. The English version shall prevail in case of any discrepancy between the translated and English versions.

15.4 Trademarks

Notice: All referenced brands, product names, service names and trademarks are the property of their respective owners.

16. Contact information

For more information, please visit: <http://www.nxp.com>

For sales office addresses, please send an email to: salesaddresses@nxp.com

17. Contents

1	General description	1
2	Features and benefits	1
3	Ordering information	2
4	Functional diagram	2
5	Pinning information	4
5.1	Pinning	4
5.2	Pin description	4
6	Functional description	5
6.1	Function table	5
7	Limiting values	5
8	Recommended operating conditions	6
9	Static characteristics	6
10	Dynamic characteristics	10
11	Waveforms	15
12	Package outline	18
13	Abbreviations	21
14	Revision history	21
15	Legal information	22
15.1	Data sheet status	22
15.2	Definitions	22
15.3	Disclaimers	22
15.4	Trademarks	23
16	Contact information	23
17	Contents	24

Please be aware that important notices concerning this document and the product(s) described herein, have been included in section 'Legal information'.

© NXP B.V. 2012.

All rights reserved.

For more information, please visit: <http://www.nxp.com>

For sales office addresses, please send an email to: salesaddresses@nxp.com

Date of release: 10 August 2012

Document identifier: 74HC_HCT373_Q100