

APPLICATIONS

- **Powered Speaker Products**
- **Sound Bars**
- **Docking Stations**
- **Internet Radio**
- **MP3 Players**
- **Stereo Headsets (wired or wireless)**
- **Televisions**
- **Home Theatre**
- **Other audio products**

KEY FEATURES

- **Input**
 - I2S, 2-channels
 - TDM, up to 8-channels
- **Output**
 - 2.2.1 (2.1 + crossover) or any subset
 - I2S x 3; 6-channels
 - TDM x 1; up to 8-channel frame
- **DC Blocking**
- **AGC supports special modes**
 - Night, Commercial, Dynamic Loudness
- **Psychoacoustics**
 - High Frequency Restoration
 - Spatialization
 - Virtual Bass
- **Dynamic Bass and Treble**
- **Parametric Equalization**
- **User Controlled Graphic Equalization**
- **Profiles: Single-pin control with tone feedback**
- **Digital volume control with Mute**
- **Compression: Soft Clipper**
- **Advanced noise-shaping Bi-quad structure**
- **Self-booting**
- **Optional microcontroller can dynamically reconfigure system via I2C or SPI**
- **Low power: 1.8V Core, 1.8V – 3.3V IO, ~22 mW @ 48ksp/s, ~50 uW standby**
- **Cost effective**
 - Microcontroller-less system; QF3DFX + EEPROM + 4 switches

DESCRIPTION

A powerful 3-channel audio filter and effects system-on-a-chip designed for seamless insertion in an audio serial digital data path. The QF3DFX is easily configured using the Quickfilter's QFPro™ Design Software (QFPro) with royalty free user tunable advanced audio algorithms for psychoacoustic effects. The QF3DFX can be configured to interface with I2S or TDM based audio systems. The QF3DFX can operate over a broad range of data rates up to 48ksp/s and can support data resolutions of 16 or 24 bits. The QF3DFX is self-booting and provides pin control for volume up, volume down, mute and profiles supporting cost sensitive designs with minimal external requirements. The QF3DFX automatically powers down when audio data is not present.

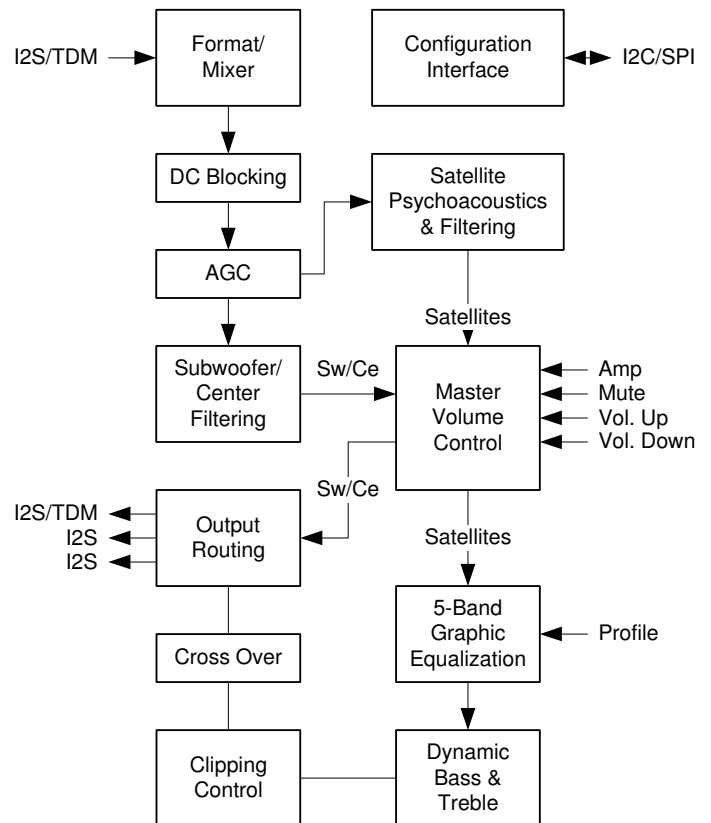

1 CONTENTS

2 PINOUT AND PIN DESCRIPTIONS..... 4

3 CLOCKING AND RESET 5

3.1 Clocking 5

3.2 Power Ramping and Reset 5

4 GENERAL DESCRIPTION..... 6

4.1 General 6

4.2 Format/Mixer 6

4.3 DC Blocking, DCB 7

4.4 Automatic Gain Control, AGC 7

4.5 Subwoofer/Center, Sw/Ce 7

4.6 High Frequency Restoration, HFR 7

4.7 Spatialization, SP 7

4.8 Virtual Bass, VB 8

4.9 Parametric Equalization, PEQ..... 8

4.10 Master Volume Control, MVC 8

4.11 5-Band Graphic Equalizer, GEQ 8

4.12 Dynamic Bass and Treble, DYB/DYT 9

4.13 Clipping Control 9

4.14 Crossover 9

4.15 Output Routing and Amplitude 9

4.16 Configuration Interface 9

5 CONFIGURATION INTERFACE 10

5.1 Serial Peripheral Interface (SPI) Protocol..... 12

5.1.1 Mode of Operation..... 12

5.1.2 Data Format..... 12

5.1.3 Address Spaces..... 13

5.1.4 SPI Access to EEPROM..... 16

5.2 SIB Slave 18

5.3 SIB Master/Boot..... 22

5.3.1 Introduction 22

5.3.2 Auto Loader Features..... 22

5.3.3 Supported EEPROM Characteristics:..... 22

5.3.4 EEPROM Access Flow 22

5.3.5 EEPROM Header Format..... 25

5.3.6 Data Format..... 28

5.3.7 Direct Register Addressing mode..... 29

5.3.8 Coefficient Addressing Mode Format 29

5.3.9 Page turn instruction 29

5.3.10 Stop Data Load (normal termination mode)..... 29

5.3.11 Status Register..... 29

6 DATA INTERFACE PROTOCOL..... 30

6.1 Introduction 30

6.2 Modes of Operation..... 30

| | | |
|-----------|--|-----------|
| 6.2.1 | <i>I2S, Left-Justified, Right-Justified</i> | 30 |
| 6.2.2 | <i>TDM Mode</i> | 31 |
| 6.3 | <i>Input Mixer</i> | 34 |
| 6.4 | <i>Output Mixer</i> | 35 |
| 6.5 | <i>dSDOn Output Enable Logic</i> | 35 |
| 6.5.1 | <i>DIN_PT Control</i> | 35 |
| 6.5.2 | <i>FILT_EN Control</i> | 35 |
| 6.5.3 | <i>Normal Operation</i> | 35 |
| 6.5.3.1 | <i>dSDO1</i> | 35 |
| 6.5.3.2 | <i>dSDO2 and dSDO3</i> | 36 |
| 7 | CONFIGURATION REGISTERS | 37 |
| 7.1 | <i>Register Summary</i> | 37 |
| 7.2 | <i>Register Definitions</i> | 39 |
| 8 | ELECTRICAL SPECIFICATION | 56 |
| 8.1 | <i>Absolute Maximum Ratings</i> | 56 |
| 8.2 | <i>Recommended Operating Conditions</i> | 56 |
| 8.3 | <i>Typical Performance Characteristics</i> | 57 |
| 8.3.1 | <i>DC Electrical Characteristics</i> | 57 |
| 8.4 | <i>AC Electrical Characteristics</i> | 59 |
| 8.4.1 | <i>SPI Configuration Timing Requirements</i> | 59 |
| 8.4.2 | <i>SIB Timing Requirements</i> | 60 |
| 8.4.3 | <i>Audio Data Path Timing Requirements</i> | 61 |
| 8.4.4 | <i>Miscellaneous Timing Requirements</i> | 62 |
| 9 | CONNECTION DIAGRAMS | 63 |
| 9.1 | <i>Electrical Connections</i> | 63 |
| 9.2 | <i>Example Systems</i> | 64 |
| 9.2.1 | <i>SPI-Based Microcontroller</i> | 64 |
| 9.2.2 | <i>SIB-Based Microcontroller</i> | 65 |
| 9.2.3 | <i>SPI-Based Microcontroller with QF3DFX Boot EEPROM</i> | 66 |
| 10 | PACKAGING INFORMATION | 67 |
| 10.1 | <i>Package Assembly</i> | 67 |
| 11 | ORDERING INFORMATION | 68 |

2 PINOUT AND PIN DESCRIPTIONS

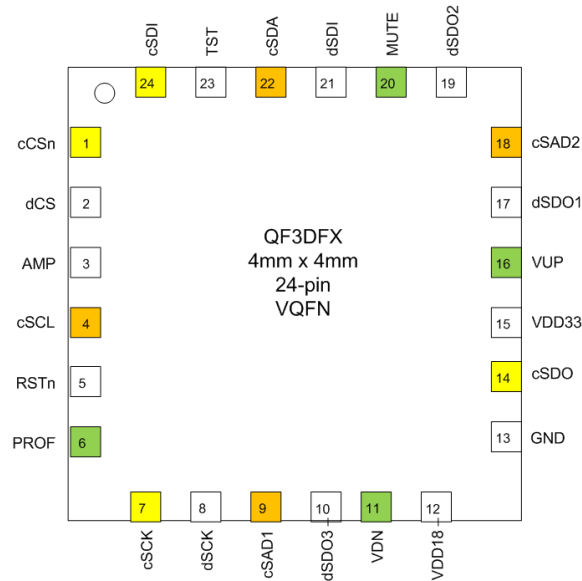

Figure 2-1 - 24 Pin QFN Package Pinout

| Pin | Signal Name | I/O | Type | Description |
|-----|-------------|-----|---------|---|
| 1 | cCSn | I | Digital | SPI configuration chip select; active low; default internal pull-up |
| 2 | dCS | I | Digital | I2S / TDM chip select; configurable as active low or high |
| 3 | AMP | I | Digital | Will Reduce overall amp gain by programmed value if asserted |
| 4 | cSCL | I/O | Digital | I2C configuration Clock |
| 5 | RSTn | I | Digital | Chip reset; active low; default internal pull-up |
| 6 | PROF | I | Digital | Round robin cycles through profiles |
| 7 | cSCK | I | Digital | SPI configuration input clock; rising capture edge |
| 8 | dSCK | I | Digital | I2S / TDM data input clock; either rising or falling capture edge |
| 9 | cSAD1 | I | Digital | I2C configuration address 1 |
| 10 | dSDO3 | O | Digital | I2S data output |
| 11 | VDN | I | Digital | Volume Down |
| 12 | VDD18 | N/A | Power | Digital Core voltage; 1.8V Fixed |
| 13 | GND | N/A | Return | Digital power supply return pin |
| 14 | cSDO | O | Digital | SPI configuration serial data output |
| 15 | VDD33 | N/A | Power | Digital I/O voltage; 1.8V – 3.3V |
| 16 | VUP | I | Digital | Volume Up |
| 17 | dSDO1 | O | Digital | I2S / TDM data output |
| 18 | cSAD2 | I | Digital | I2C configuration address 2 |
| 19 | dSDO2 | O | Digital | I2S data output |
| 20 | MUTE | I | Digital | Mute |
| 21 | dSDI | I | Digital | I2S / TDM serial data input |
| 22 | cSDA | I/O | Digital | I2C configuration Data |
| 23 | TST | I | Digital | Test Mode – Tie to GND or let float |
| 24 | cSDI | I | Digital | SPI configuration data input |

Table 2-1 Pin Descriptions

3 CLOCKING AND RESET

3.1 Clocking

There are minimal clocking requirements for the QF3DFX. The internal design is fully static; there is no internal dynamic circuitry. None of the clocks need to be continuously running.

cSCK and cSCL have no particular requirements aside from standard minimum high and low and max frequency limitations, usually due to their respective protocols. Both clocks can operate down to DC. Additional details can be found in the Timing Requirements section.

dSCK and dCS work together, and are typically generated from a crystal or other stable timebase. This is usually a requirement of the ADC's and DAC's they connect to. They do not need to be free running or continuously operating for the QF3DFX to operate. It is perfectly acceptable to freeze dSCK and dCS for power savings reasons, for example, and once they begin operating again, the QF3DFX will pick up exactly where it left off in the signal processing flow. Care should be taken that no clock glitches occur that may cause spurious data to enter the chip.

3.2 Power Ramping and Reset

The QF3DFX contains state logic that must be correctly initialized upon power-up before being used. This initialization is accomplished by having RSTn be asserted after V_{DD33} and V_{DD18} have reached valid operating levels as shown below. RSTn does not have to be high prior to being asserted. The low level alone will perform the initialization. There is no restriction on the relationship of the VDD33 ramp to the VDD18 ramp. Either may be ramped before the other or they may ramp together. However, both VDD33 and VDD18 must be at valid levels for the RSTn assertion to be recognized.

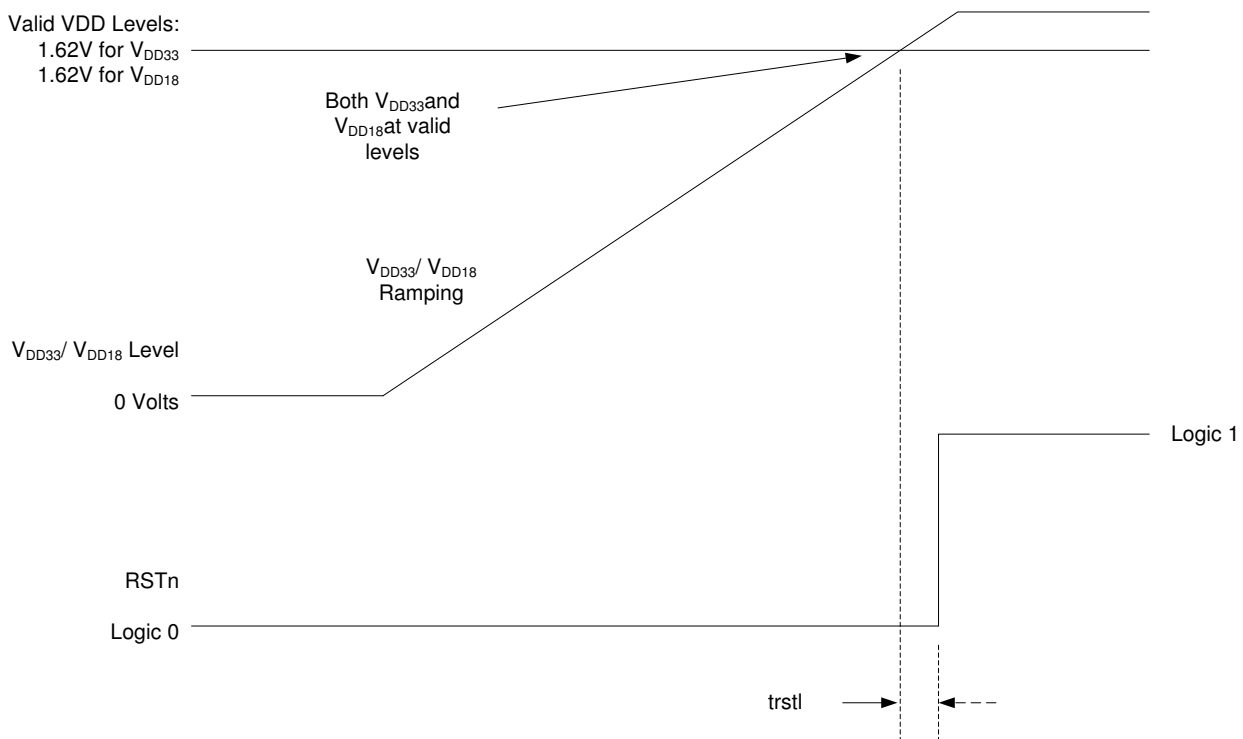

Figure 3-1 - Power-up Sequence and Reset

4 GENERAL DESCRIPTION

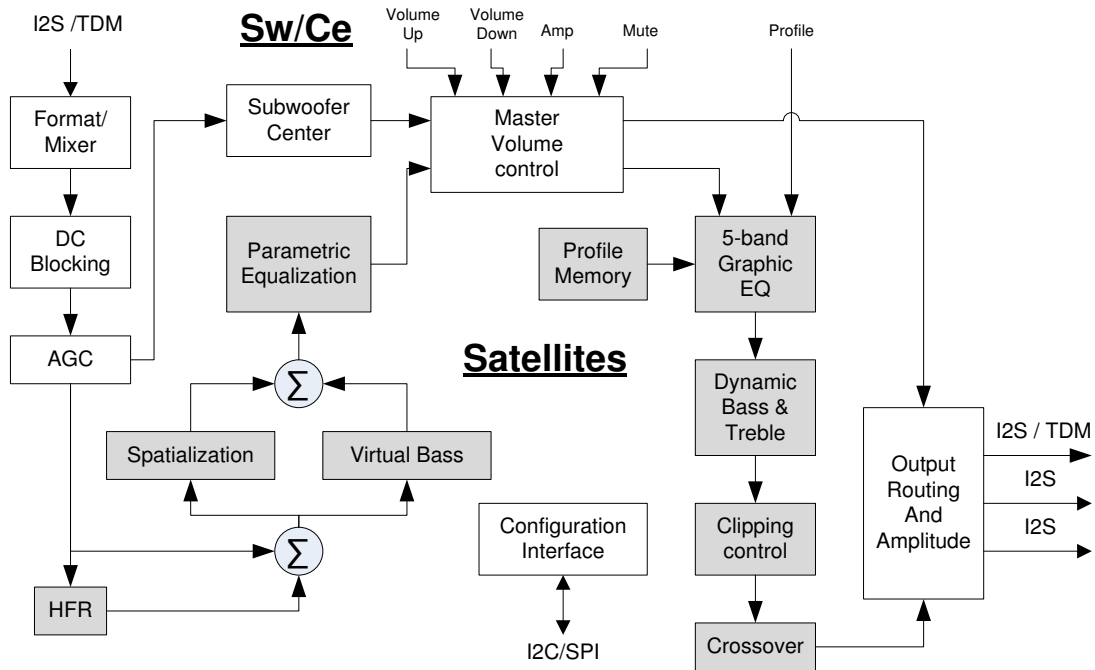

Figure 4-1 - Functional Block Diagram

4.1 General

The QF3DFX is internally a three channel audio filtering and effects system. The serial data interface can accept as input either 2 channels of I2S or up to 8 channels of TDM. The 3 internal audio channels are created by scaling and summing these incoming channels. All 3 channels receive DC blocking and automatic gain control. The Subwoofer/Center, Sw/Ce, channel is directed to a series of filters for band limiting and parametric equalization. The two satellite channels pass through psychoacoustic effects blocks consisting of high frequency restoration, virtual bass and spatialization. The satellite channels then pass through parametric equalization and enter a master volume block. The volume can be controlled externally via 3 pins; there is also provision for external amplifier thermal feedback compensation. The graphical equalization can also be externally controlled with one pin, profiles, with a provision for tone acknowledgement of the selected profile. Both the volume and graphical equalization can take on more elaborate forms of presentation in systems utilizing a microcontroller. Dynamic bass and treble are available for the satellite channels. Numerous forms of soft signal management are available to control clipping. The satellite channels have a crossover option creating 2 additional channels. The output is capable of routing any internal channel to any output port or slot position. Each output can have a unique gain value applied and, optionally, inverted.

Several QF3DFX devices can be used in series to process all the channels of a TDM stream or in parallel utilizing I2S.

4.2 Format/Mixer

Serial audio streams of 16 or 24-bit data of I2S, Left Justified, Right Justified, or TDM are supported. The input block creates 3-channels of audio data from these sources. For I2S data, the 2 satellite channels can be summed and reduced, user programmable, to form the 3rd channel. For TDM data, any of the channels within the TDM stream can be scaled and mixed to any of the 3 internal channels (2 satellite channels and 1 subwoofer/center channel).

The serial audio data can be in 2's complement or offset binary format with MSB first.

The QF3DFX utilizes the incoming bit clock and framing signal to exit power down mode and process the incoming serial audio data stream. The QF3DFX returns to power down mode when these are not active.

If desired, the QF3DFX can be bypassed. The bypass function simply routes the input (dSDI) to the output (dSDO1).

4.3 DC Blocking, DCB

This block provides the classic audio DC blocking filtering and is used to meet the overall system DC blocking rejection requirements.

4.4 Automatic Gain Control, AGC

The function of the of the AGC is to keep the input signal energy between the high and low threshold values, each with programmable gain, attack time and release time. The satellite channels share common configuration settings and the Sw/Ce channel has independent settings.

The attack time parameter controls how fast the signal is lowered when it is above high threshold while the release time parameter controls how fast the signal is raised when below the low threshold. The AGC can be programmed to ignore energy levels that are below the noise threshold value. The AGC is fully capable of supporting dynamic range compression.

The averaging time is programmable to support special modes such as Night mode and Commercial mode. Night mode prevents loud audio content when listening to audio at low levels. The AGC works to quickly reduce loud sounds only and does not increase quiet sounds. Commercial content has a higher energy value than the program content and is perceived as having more volume. The AGC works to quickly lower the commercial volume only without effecting program volume.

4.5 Subwoofer/Center, Sw/Ce

The Sw/Ce block provides an equalizing function for Sw/Ce channel processing. It is comprised of 7 biquad IIR filters for band limiting and parametric equalization. The Sw/Ce block output gain is independently adjustable for balancing with the satellite channel gain.

QFPro's parametric equalization design tool can be used to dynamically view composite results while selecting filter types (including custom; imported) and adjusting corresponding parameters.

4.6 High Frequency Restoration, HFR

The HFR block uses psychoacoustic techniques to help restore high frequency content that may have been lost due to audio compression or other processing. Many audio compression algorithms, such as that used with MP3 encoding, limit the high frequency content in order to reduce file size and transmission overhead. For reduced bit rate compressed audio, frequencies as low as 10 kHz may be removed. The HFR block restores this lost data. The HFR block can also be used on full-band audio to emphasize high frequency content, to compensate for speaker performance, as a system designer preference or to satisfy market requirements.

Using QFPro, this function is programmable and includes gain control for mixing the resulting effect back with the primary audio data. A common setting is applied to both satellite channels.

4.7 Spatialization, SP

The SP block uses a psychoacoustic algorithm to enhance the sense of stereo separation in an audio signal. Many audio platforms have speakers that are in close proximity, and therefore do not have the desired stereo separation or a sense of spaciousness. The SP block enhances the stereo separation that is present in audio data to increase the apparent speaker separation.

In conjunction with QFPro, the Spatialization function is highly configurable with fully independent main and effect processing for enhanced audio separation.

4.8 Virtual Bass, VB

With smaller enclosures come corresponding smaller speakers which often do not reproduce bass frequencies well. By using Quickfilter's VB psychoacoustic effects block, more apparent bass can be added to the satellite channels.

Common settings are utilized for both satellite channels. Using QFPro, this function is highly programmable and includes gain control for mixing the resulting effect back with the primary audio data.

4.9 Parametric Equalization, PEQ

The Parametric Equalizer is used to correct or adjust system and speaker related performance attributes and is comprised of ten 2nd-order IIR (biquad) filters in series. A common set of filter coefficients is applied to both satellite channels.

QFPro's parametric equalization design tool can be used to dynamically view composite results while selecting filter types (including custom; imported) and adjusting corresponding parameters.

4.10 Master Volume Control, MVC

The MVC comprises volume, mute, and amplifier protection features for both the satellite and Sw/Ce channels.

A single master gain value gets applied to each of the three channels. This gain can be varied from +24 to -102 dB (plus mute) in 1 dB steps. A user can sequence nonlinearly through this range two ways:

- A 100-step user-programmable table of volume levels. An index pointer can sequence up and down through this table under the control of the VUP and VDN pins, permitting the volume to increase and decrease in steps defined by the developer.
- Directly by a SPI or SIB bus master.

The MVC block also includes a user programmable slew rate to manage user-controlled volume changes.

Volume Up, Volume Down, and Mute can be controlled via the VUP, VDN, and MUTE pins, if desired. This method of controlling volume is useful if there is no external microcontroller in the system. At Power-on Reset, each pin is configured with an internal pull-up resistor enabled. Therefore, the only external hardware required to implement these functions is a momentary switch that, when closed, will drive the pin level to ground. Internal logic provides a debounce function; there is no need for external debouncing circuitry. If Autorepeat is enabled through QFPro, holding the VUP pin or VDN pin low for approximately two seconds will cause the gain to change repeatedly up or down, as appropriate. Repeatedly toggling the MUTE pin low (default state is high) will alternately mute and un-mute all three channels simultaneously.

An amplifier protection pin, AMP, is provided to aid in the protection of amplifiers that don't have thermal or other protection from very loud signals. At Power-on Reset, this pin is configured with an internal pull-down resistor enabled. If the pin is held high for at least 30 ns, the volume is decreased by 3 dB (default value). Other attenuation values can be programmed as well. The reduced volume will remain until AMP is deasserted.

Volume changes brought about by VUP, VDN, MUTE, or PROF pushbutton presses or their corresponding register accesses will be slew rate controlled to minimize popping sounds. The AMP pin is slew rate controlled as well.

4.11 5-Band Graphic Equalizer, GEQ

The GEQ is a 5-band graphic equalizer that can be controlled by the product's end user. Each of the 5 parallel bands is composed of a 2nd order IIR filter whose gain can be independently varied from +15 dB to -15 dB. Each profile consists of a set of gains (five per profile) for 1 to 8 profiles as established by the developer.

The product's end user can control the GEQ by choosing one of up to eight unique profiles. This is accomplished by either the PROF pin or other interfaces supported by a microcontroller, SPI or SIB bus master, directly setting the internal GEQ registers.

The PROF pin method of controlling frequency response is useful if there is no external microcontroller in the system. Each time the PROF pin is momentarily toggled low, the profile pointer advances to the next profile in a round-robin fashion. The PROF pin is configured similar to the volume pins described above. There is an option for a tone to be generated as the profile pointer advances to the next profile, with a unique pitch signifying the transition from the last profile in the sequence back to the first.

4.12 Dynamic Bass and Treble, DYB/DYT

Dynamic bass compensates for the increased difficulty in hearing bass as the volume is decreased. The DYB block compensate for this by boosting lower frequencies as their energy level or amplitude decreases.

Dynamic treble compensates for the increased difficulty in hearing treble as the volume is decreased. The DYT block will boost the higher frequencies.

Dynamic bass and dynamic treble can be independently enabled and, using QFPro, are highly programmable with respect to operating frequency range and corresponding amplitudes.

4.13 Clipping Control

A user-programmable soft clipper algorithm is available in the QF3DFX. This algorithm applies attenuation to each sample in a non-linear fashion based on that sample's incoming amplitude. After this attenuation, the entire waveform can be gain compensated to create a signal that sounds louder than the original, but with no greater amplitude than the original.

4.14 Crossover

The crossover block will split each staelite channel into two frequency bands by way of a high pass filter and a low pass filter. This allows the user to better match the low and high frequencies to the speakers (e.g. woofers and tweeters). The filters will be in the form of a crossover filter in which each will share the same corner frequency. The block is comprised of eight 2nd order filters capable of many types of crossover structures including the classic Linkwitz-Riley filter with independent gain settings.

4.15 Output Routing and Amplitude

For the I2S or TDM outputs, any of the 5 internal channels (2.2.1; 2.1+ crossover) may be directed to any of the available 6 output I2S channels or 8 TDM slots including directing a single channel to multiple slots and ports.

The amplitude of each the 5 internal channels can be independently set and optionally inverted, allowing for the creation of digital differential outputs.

4.16 Configuration Interface

The Configuration Interface is used to read and write the register and memory spaces. It supports both SIB and SPI protocols. The SIB can function as both a master and a slave. The SPI operates only as a slave. There are 2 address pins available for SIB system requirements.

The Configuration Interface supports self booting (configure and run) from an external SIB-based EEPROM. The EEPROM is also utilized to save user controlled volume and profile setting for reinstatement at power up.

The external SIB EEPROM is a standard 16-bit format device.

The SPI Interface is capable of operating up to 25 MHz, while the I2C interface can run up to 400 kHz. Both interfaces can run with a clock frequency down to DC.

5 CONFIGURATION INTERFACE

The configuration interface consists of a SPI interface and a standard 2-wire interface, referred to in this document as the Serial Interface Bus (SIB), with the following features:

- SIB Interface
 - Pins are cSCL and cSDA and are I2C compatible
 - Both a master and a slave
 - Boot interface that supports a variety of EEPROMs
 - Schmitt trigger input levels are always enabled on the SIB pins
- SPI Interface
 - Slave Only
- SPI to SIB Bridge
 - Can program the SIB EEPROM from a SPI Master
 - Can access any slave device on the SIB from a SPI Master
- Flexible microprocessor support
 - Zero, one, or multiple microprocessors supported
 - Multiple microprocessors may require system (off-chip) arbitration

Figure 5-1 Configuration Dataflow Diagram, is the overall block diagram for the configuration interface. The functionality of the blocks is summarized below.

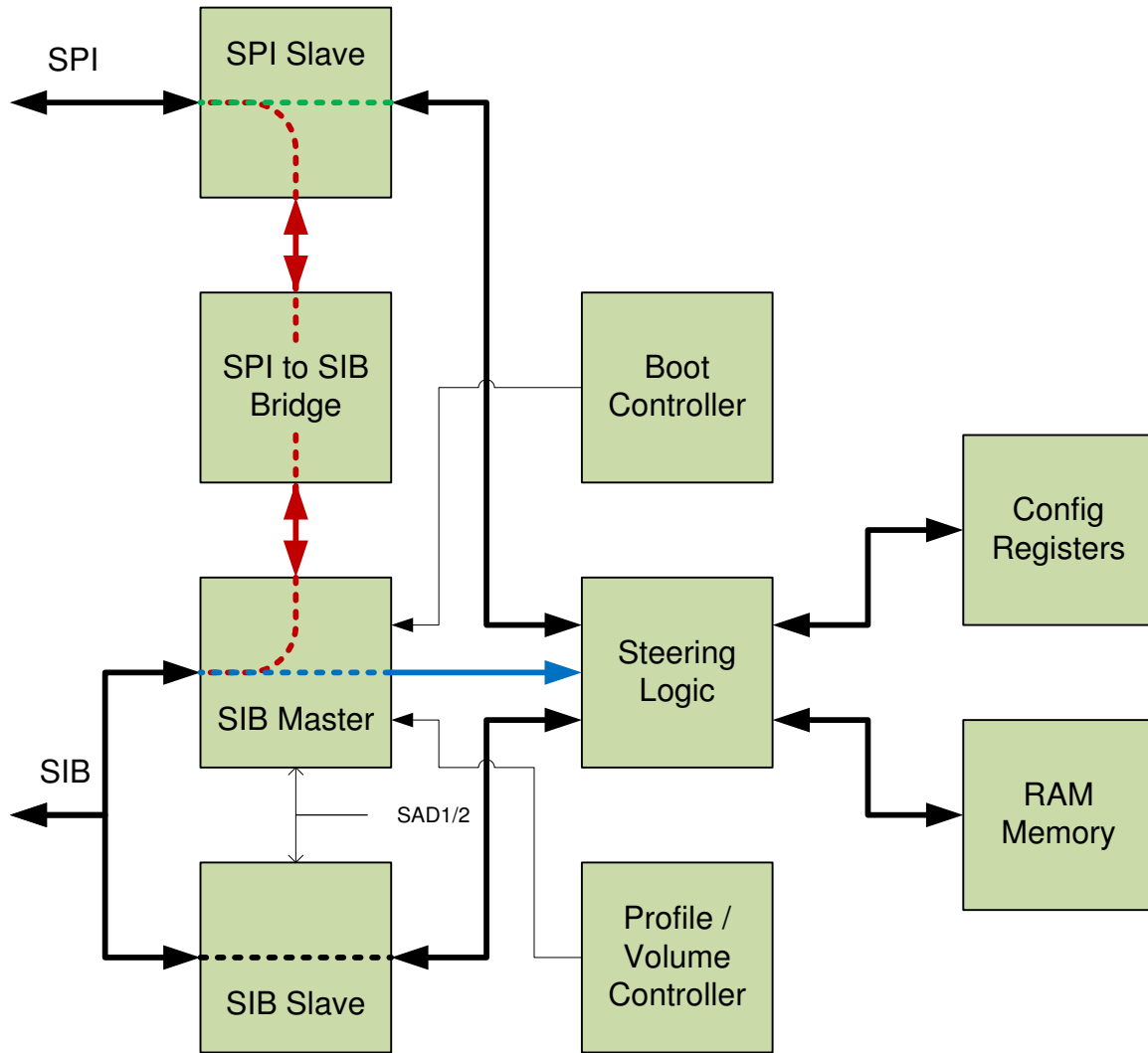

Figure 5-1 Configuration Dataflow Diagram

SPI Slave – Through this interface, an external SPI master can access (read or write) the register space, the memory space, and the SIB bus.

SPI-to-SIB Bridge – This allows an external SPI master to access the SIB bus. Using this bridge is one method in which the system can program the associated SIB EEPROM.

SIB MASTER – Its main purpose is to access an external SIB EEPROM during boot-up. The boot block will, following reset, use the SIB master to access an EEPROM, if one exists. An external SPI master can also use the SIB master to access an SIB-based EEPROM, or any other slave device on the SIB.

SIB SLAVE – The SIB Slave is used by an external SIB master to access (read or write) the register and memory spaces.

BOOT CONTROLLER – This block, following reset, will cause the SIB Master to attempt an access to an external SIB EEPROM. It will check to see if an EEPROM is on the bus and then, via a predefined header format, determine if the data

in the EEPROM is valid for the QF3DFX. If the data is valid, it will then transfer the data from the EEPROM to the register and memory spaces in the QF3DFX.

PROFILE / VOLUME CONTROLLER – This block will update an external SIB EEPROM with current profile and volume information. In an implementation that does not include a microprocessor, this block allows the last settings of the profile and volume to be saved to an external SIB EEPROM.

STEERING LOGIC – This block determines which controller can access (read or write) to the register and memory spaces. The boot block has highest priority, followed by the SPI interface, with the SIB slave interface having the lowest priority.

CONFIG REGISTERS – This block represents the chip’s configuration register space.

MEMORIES – This block represents the chip's ram-based memory spaces, holding volume table, coefficient, reserved information, and data information.

The following sections describe each of the blocks and the interface protocol for each.

5.1 Serial Peripheral Interface (SPI) Protocol

5.1.1 Mode of Operation

The QF3DFX is designed to interface directly with the serial peripheral interface (SPI) of microcontrollers and Digital Signal Processors. The QF3DFX SPI slave mode uses the **cSDI**, **cSDO**, **cSCK**, and **cCSn** pins. **cSDI** is the input serial data, and **cSDO** is the output serial data. **cSCK** is the input serial clock. **cCSn** is the SPI peripheral select line. The configuration registers can be both read and written while audio data is being processed. Coefficient and Volume data accesses must not be attempted while audio data is being processed.

5.1.2 Data Format

In order to address and read/write to the QF3DFX, **cCSn** is asserted low to select the device. If **cCSn** is not asserted, data will not be accepted via the serial input pin (**cSDI**) and the serial output pin (**cSDO**) will remain in a high impedance state.

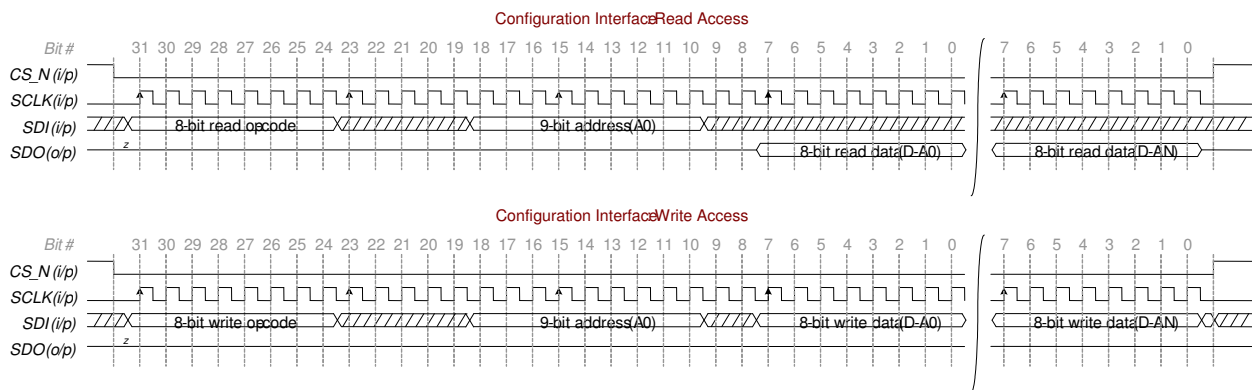

Figure 5-2: Configuration Data Timing

Important Notes

- There are **five** “don’t care” clock cycles between the end of the op code and the 9-bit address. The value of **cSDI** during these clocks has no effect on the chip. There are also **two** “don’t care” clock cycles between the end of the address input and data output on the **cSDO** pin.
- **cSDO** transitions are always based from the falling edge of **cSCK**
- **cSDI** is always sampled on the rising edge of **cSCK**
- **cSDO** is tri-stated when **cCSn** is high
- Holding **cCSn** low continues data read/write accesses
- Read Opcodes: Register Space = 0x83, Reserved Space = 0x85, Coefficient RAM Space = 0x87, Volume RAM Space = 0x92
- Write Opcodes: Register Space = 0x82, Reserved Space = 0x84, Coefficient RAM Space = 0x86, Volume RAM Space = 0x93
- SPI-to-SIB Opcodes: Write SIB = 0x94, Continue Write SIB = 0x95, Read SIB = 0x96, SIB Done = 0x97
- The address for the Configuration Registers is a byte address, e.g. to read the VERSION register, the address would be 0x02.
- The address for the Resereved RAM identifies the reserved location to be accessed, e.g. to write the 4th reserved location directly, the address would be 0x03 [1st resrv addr = 0x00, 2nd resrv addr = 0x01, 3rd resrv addr = 0x02, 4th resrv addr = 0x03]. Each reserved location is six bytes wide. There are 512 coefficient locations resulting in the address being 9 bits wide.
- The address for the Coefficient RAM identifies the coefficient to be accessed, e.g. to write the 4th coefficient directly, the address would be 0x03 [1st coeff addr = 0x00, 2nd coeff addr = 0x01, 3rd coeff addr = 0x02, 4th coeff addr = 0x03]. Each coefficient is three bytes wide. There are 512 coefficient locations resulting in the address being 9 bits wide.
- The address for the Volume RAM identifies a 7-bit gain value to be accessed, e.g. to write the 4th gain value directly, the address would be 0x03 [1st gain value. addr. = 0x00, 2nd gain value addr = 0x01, 3rd gain value addr = 0x02, 4th gain value addr = 0x03]. Each gain value is seven bits wide. There are 100 gain value locations resulting in the address being 7 bits wide.

5.1.3 Address Spaces

The Configuration SPI interface programs four different address spaces in the QF3DFX: a Configuration Register space, a Coefficient Memory space, a Reserved Memory space, and a Volume Memory space. The Configuration Register space is accessed when the Opcodes 0x82/0x83 are used. The Reserved Memory space is accessed when the Opcodes 0x84/0x85 are used. The Coefficient Memory space is accessed when the Opcodes 0x86/0x87 are used. The Volume Memory is accessed when Opcodes 0x92/0x93 are used.

Multiple successive registers or memory values may be read or written by simply appending 8-bit data values after the first data value is read or written. Thus an entire Coefficient, Volume, Configuration Register, or Reserved Memory space may be read or written with a single write access.

Each 48-bit reserved location is written Most Significant Bit and Most Significant Byte first. Each 24-bit coefficient is written Most Significant Bit and Most Significant Byte first. Each 8-bit configuration register is written Most Significant Bit first. Certain configuration values span more than one byte. These get written Least Significant Byte first, but Most Significant Bit first (within a byte). The volume memory only uses the lower 7 bits; therefore, the MSb (Most Significant bit of the byte) is a don’t-care. The table below summarizes this.

| Registers | Address Range | Data Size [†] | Write Opcode | Read Opcode |
|-------------------------|----------------------|------------------------|--------------|-------------|
| Configuration Registers | 0x00 – 0x9C (0-156) | 8 bits | 0x82 | 0x83 |
| Reserved Values | 0x00 – 0x1FF (0-511) | 48 bits | 0x84 | 0x85 |
| Coefficients | 0x00 – 0x1FF (0-511) | 24 bits | 0x86 | 0x87 |
| Volume | 0x00-0x63 (0-99) | 7 bits | 0x92 | 0x93 |

[†] Multiple registers can be written / read by extending the SPI access cycle

Table 5-1: Register and Memory Access Formats

Note: When the Mode Control Register (register 03h) contains a value of one (01h), the QF3DFX is in Filter Mode and the Coefficient, Volume, and Reserved Memory spaces cannot be accessed. In this mode, only the Configuration Registers can be freely accessed. In order to freely read and write any memory space location, the Mode Control Register must be written with a value of zero (00h).

The following are examples of SPI writes and reads to configuration, coefficient, and volume memory spaces.

- 1) SPI write to the first four registers with data of 0x11, 0x22, 0x33 and 0x44.
Bit Stream: 0x82, 0xX (5), 0x000 (9), 0xX (2), 0x11223344

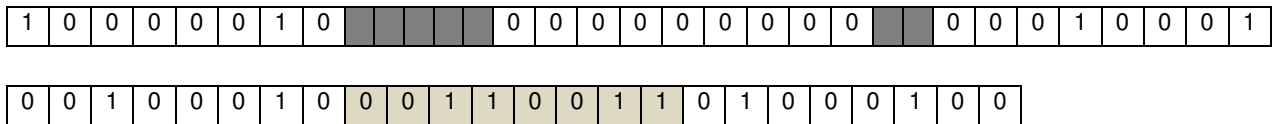

- 2) SPI read of address 0x00 with data of 77
Bit Stream: 0x83, 0xX (5), 0x000 (9), 0xX (2), Data (received)

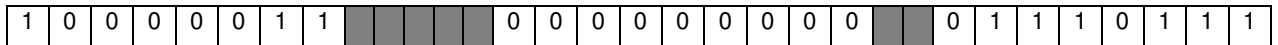

- 3) SPI write to coefficient memory at address 0x100 with data of 0xaabccc.
Bit Stream: 0x86, 0xX (5), 0x100 (9), 0xX (2), 0xaabccc

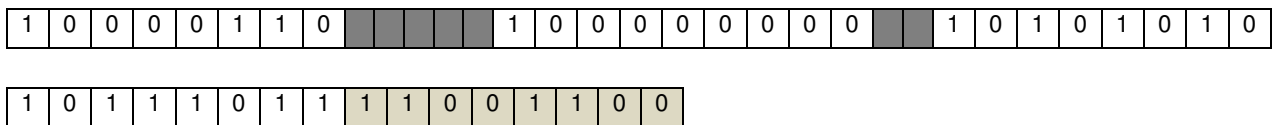

- 4) SPI write to the first four volume memory locations with data of 0x11, 0x22, 0x33 and 0x44.
Bit Stream: 0x92, 0xX (5), 0x000 (9), 0xX (2), 0x11223344

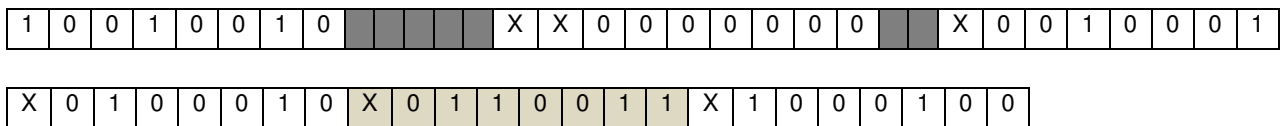

- 5) SPI read of the first four volume memory locations with data of 0x11, 0x22, 0x33 and 0x44.

Bit Stream: 0x92, 0xX (5), 0x000 (9), 0xX (2), 0x11223344. Note that the Most Significant Bit is always returned as 0.

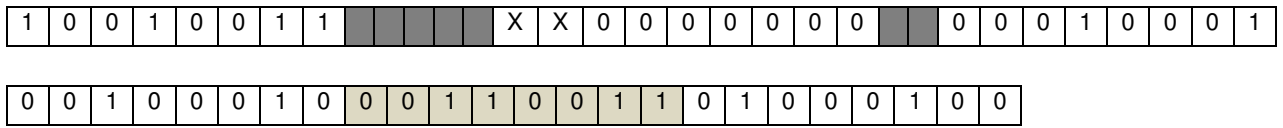

5.1.4 SPI Access to EEPROM

The SPI interface can read and write an external SIB EEPROM. Several Opcodes are used to accomplish this: 0x94 through 0x97. Opcode 0x94 sent from the external SPI master initiates a write to the SIB bus. This write can only have one byte of data. The external SPI master must then poll the SPI_TO_I2C status register to see when it may begin the next write. Typically, the SPI will be able to keep data flowing uninterrupted to the SIB bus. A second Opcode, 0x95, is provided in order to allow the external SPI master to issue a write command without the need for address information. A third Opcode, 0x96, is provided to do a single byte read from the EEPROM. A fourth Opcode, 0x97, will end the write (either due to reaching a page boundary in the EEPROM or on the completion of the EEPROM access). The Opcodes are summarized in the following table.

| Access Type | Data Size | Opcode |
|----------------------------|-----------|--------|
| SPI to SIB Write | 8 bits | 0x94 |
| SPI to SIB continued Write | 8 bits | 0x95 |
| SPI to SIB Read | 8 bits | 0x96 |
| SPI to SIB Done | N/A | 0x97 |

Table 5-2: SPI-to-SIB Accesses

The following table shows the information that the SPI Master must provide for each of the four Opcodes.

| Access Type | Information |
|----------------------------|---|
| SPI to SIB Write | Opcode, Device Address, Internal Address High, Internal Address Low, Data |
| SPI to SIB continued Write | Opcode, Data |
| SPI to SIB Read | Opcode, Device Address, Internal Address High, Internal Address Low |
| SPI to SIB Done | Opcode, Device Address |

Table 5-3: SPI-to-SIB Accesses

Example 1

This example of a SPI to SIB write assumes an EEPROM with a Device Address = 0xA0. The write will begin at the EEPROM address of 0x0 and write four bytes: 0x11, 0x22, 0x33, and 0x44.

- 1) To initiate the write the SPI Master would write out the following information (in the manner as shown in Figure 5-2: Configuration Data Timing).
 - a. 0x94, 0xX, 0x0A0, 0xX, 0x0, 0x0, 0x11 (8-bit opcode, 5 don't cares, 9-bit address, 2 don't cares, 8-bit internal address high, 8-bit internal address low, 8-bit data)

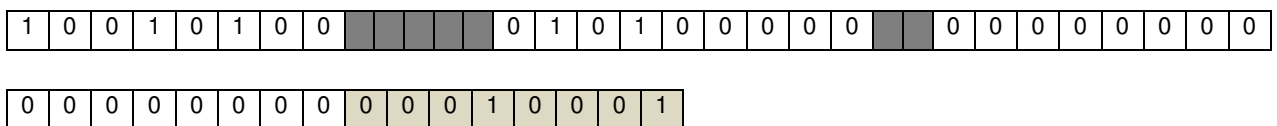

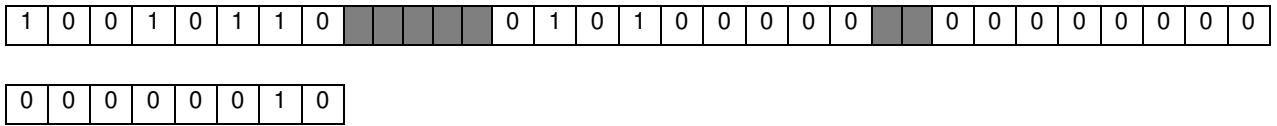

2) The SPI Master must now poll the SPI_TO_SIB register bit 3, which, when set, indicates that the SIB read is complete.

- a. 0x83, 0xX, 0x1E, 0xX, 0xD (8-bit opcode, 5 don't cares, 9-bit register address, 2 don't cares, received data)

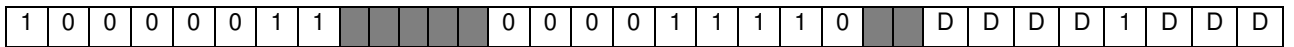

3) The SPI Master can read the SIB data register in which the requested byte of EEPROM data will be located.

- a. 0x83, 0xX, 0x1F, 0xX, 0xD (8-bit opcode, 5 don't cares, 9-bit register address, 2 don't cares, received data)

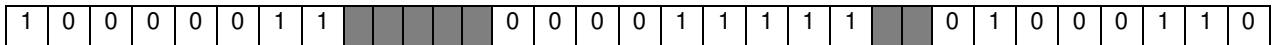

5.2 SIB Slave

The QF3DFX SIB Slave interface can access the Configuration Registers and the Coefficient, Reserved, and Volume Memory spaces. The SIB Slave interface uses several opcodes to accomplish writes and reads.

Following boot and until the internal initialization is complete, the SIB Slave interface will not allow an external master access to the Configuration Registers or to the memories. The slave will return a no acknowledge during the device address phase. Table 5-4: SIB Slave Opcodes lists the opcode for each type of slave access.

| Registers | Address Range | Data Size | Read/Write Opcode |
|-------------------------|----------------------|-----------|-------------------|
| Configuration Registers | 0x00 – 0x77 (0-119) | 8 bits | 0x82 |
| Reserved Memory | 0x00 – 0x1FF (0-511) | 48 bits | 0x84 |
| Coefficients Memory | 0x00 – 0x1FF (0-511) | 24 bits | 0x86 |
| Volume Memory | 0x00 – 0x63 (0-99) | 7 bits | 0x92 |

Table 5-4: SIB Slave Opcodes

The SIB master must begin an access (either read or write) with the device address. The device address for the QF3DFX SIB slave is a combination of the hard coded value of 0xc0, the value of two external pins SAD1 and SAD2, and the Read/Write bit. The results in the slave address equaling:

| | | | | | | | |
|---|---|---|---|---|------|------|-----|
| 1 | 1 | 0 | 0 | 0 | SAD2 | SAD1 | R/W |
|---|---|---|---|---|------|------|-----|

After the device address has been sent, the SIB master must send the opcode (see Table 5-4: SIB Slave Opcodes). Following the opcode, the 2-byte address for the internal destination in QF3DFX (register or memory address) is sent. The upper byte (first one sent) will be all zeros for register accesses and for volume memory accesses. The Coefficient Memory and the Reserved Memory will use the least significant bit of the upper byte. Following the address, the SIB master sends the data. The data is in byte format with the most significant byte first. Below are some examples.

Note: ACK = Acknowledge, NAK = No Acknowledge, RST = Restart (the START and STOP conditions are not shown)

Example 1: An external SIB Master write to configuration register 0x00 with a data of 0x55.

SAD2 = SAD1 = 0

| | | | | | | | | | | | | | | | | | | | | | | | | | | | | | | | | | | | | | | |
|---|---|---|---|---|---|---|---|-----|---|---|---|---|---|---|---|---|---|---|---|---|---|---|---|---|---|---|---|---|---|---|---|---|---|---|---|---|---|---|
| S | 1 | 1 | 0 | 0 | 0 | 0 | 0 | R/W | A | 1 | 0 | 0 | 0 | 0 | 0 | 1 | 0 | A | 0 | 0 | 0 | 0 | 0 | 0 | 0 | 0 | 0 | 0 | A | 0 | 0 | 0 | 0 | 0 | 0 | 0 | 0 | A |
| T | | | | | | | | 0 | C | | | | | | | | | C | | | | | | | | | | | | C | | | | | | | C | |
| R | | | | | | | | | K | | | | | | | | | K | | | | | | | | | | | | K | | | | | | | K | |

| | | | | | | | | | |
|---|---|---|---|---|---|---|---|---|---|
| 0 | 1 | 0 | 1 | 0 | 1 | 0 | 1 | N | S |
| | | | | | | | | A | T |
| | | | | | | | | K | P |

Example 2: An external SIB Master read to configuration register 0x06 with expected data of 0xAA.

SAD2 = SAD1 = 1

| | | | | | | | | | | | | | | | | | | | | | | | | | | | | | | | | | | | | | |
|---|---|---|---|---|---|---|---|-----|---|---|---|---|---|---|---|---|---|---|---|---|---|---|---|---|---|---|---|---|---|---|---|---|---|---|---|---|---|
| S | 1 | 1 | 0 | 0 | 0 | 1 | 1 | R/W | A | 1 | 0 | 0 | 0 | 0 | 0 | 1 | 0 | A | 0 | 0 | 0 | 0 | 0 | 0 | 0 | 0 | 0 | A | 0 | 0 | 0 | 0 | 0 | 1 | 1 | 0 | A |
| T | | | | | | | | 0 | C | | | | | | | | | C | | | | | | | | | | | C | | | | | | | C | |
| R | | | | | | | | | K | | | | | | | | | K | | | | | | | | | | | K | | | | | | | | K |

| | | | | | | | | | | | | | | | | | | | |
|---|---|---|---|---|---|---|---|-----|---|---|---|---|---|---|---|---|---|---|---|
| R | 1 | 1 | 0 | 0 | 0 | 1 | 1 | R/W | A | 1 | 0 | 1 | 0 | 1 | 0 | 1 | 0 | N | S |
| S | | | | | | | | 1 | C | | | | | | | | | A | T |
| T | | | | | | | | | K | | | | | | | | | K | P |

Example 3: An external SIB Master write to coefficient memory address 0x111 with data of 0x112233

SAD2 = SAD1 = 0

| | | | | | | | | | | | | | | | | | | | | | | | | | | | | | | | | | | | | | |
|---|---|---|---|---|---|---|---|-----|---|---|---|---|---|---|---|---|---|---|---|---|---|---|---|---|---|---|---|---|---|---|---|---|---|---|---|---|---|
| S | 1 | 1 | 0 | 0 | 0 | 0 | 0 | R/W | A | 1 | 0 | 0 | 0 | 0 | 1 | 1 | 0 | A | 0 | 0 | 0 | 0 | 0 | 0 | 0 | 0 | 1 | A | 0 | 0 | 0 | 1 | 0 | 0 | 0 | 1 | A |
| T | | | | | | | | 0 | C | | | | | | | | | C | | | | | | | | | | | C | | | | | | | | C |
| R | | | | | | | | | K | | | | | | | | | K | | | | | | | | | | | K | | | | | | | | K |

| | | | | | | | | | | | | | | | | | | | | | | | | | | | |
|---|---|---|---|---|---|---|---|---|---|---|---|---|---|---|---|---|---|---|---|---|---|---|---|---|---|---|---|
| 0 | 0 | 0 | 1 | 0 | 0 | 0 | 1 | A | 0 | 0 | 1 | 0 | 0 | 0 | 1 | 0 | A | 0 | 0 | 1 | 1 | 0 | 0 | 1 | 1 | N | S |
| | | | | | | | | C | | | | | | | | | C | | | | | | | | | A | T |
| | | | | | | | | K | | | | | | | | | K | | | | | | | | | K | P |

Example 4: An external SIB Master read to coefficient memory address 0x113 with expected data of 0x112233

SAD2 = SAD1 = 0

| | | | | | | | | | | | | | | | | | | | | | | | | | | | | | | | | | | | | | |
|---|---|---|---|---|---|---|---|-----|---|---|---|---|---|---|---|---|---|---|---|---|---|---|---|---|---|---|---|---|---|---|---|---|---|---|---|---|---|
| S | 1 | 1 | 0 | 0 | 0 | 0 | 0 | R/W | A | 1 | 0 | 0 | 0 | 0 | 1 | 1 | 0 | A | 0 | 0 | 0 | 0 | 0 | 0 | 0 | 0 | 1 | A | 0 | 0 | 0 | 1 | 0 | 0 | 1 | 1 | A |
| T | | | | | | | | 0 | C | | | | | | | | | C | | | | | | | | | | C | | | | | | | | C | |
| R | | | | | | | | | K | | | | | | | | | K | | | | | | | | | | K | | | | | | | | K | |

| | | | | | | | | | | | | | | | | | | | | | | | | | | | | | | | | | | | | | |
|---|---|---|---|---|---|---|---|-----|---|---|---|---|---|---|---|---|---|---|---|---|---|---|---|---|---|---|---|---|---|---|---|---|---|---|---|---|---|
| R | 1 | 1 | 0 | 0 | 0 | 0 | 0 | R/W | A | 0 | 0 | 0 | 1 | 0 | 0 | 0 | 1 | A | 0 | 0 | 1 | 0 | 0 | 0 | 1 | 0 | A | 0 | 0 | 1 | 1 | 0 | 0 | 1 | 1 | N | S |
| S | | | | | | | | 1 | C | | | | | | | | | C | | | | | | | | | C | | | | | | | | A | T | |
| T | | | | | | | | | K | | | | | | | | | K | | | | | | | | | K | | | | | | | | K | P | |

Example 5: An external SIB Master write to volume memory address 0x023 with data of 0x66

SAD2 = SAD1 = 0

| | | | | | | | | | | | | | | | | | | | | | | | | | | | | | | | | | | | | |
|---|---|---|---|---|---|---|---|-----|---|---|---|---|---|---|---|---|---|---|---|---|---|---|---|---|---|---|---|---|---|---|---|---|---|---|---|---|
| S | 1 | 1 | 0 | 0 | 0 | 0 | 0 | R/W | A | 1 | 0 | 0 | 1 | 0 | 0 | 1 | 0 | A | 0 | 0 | 0 | 0 | 0 | 0 | 0 | 0 | A | 0 | 0 | 1 | 0 | 0 | 0 | 1 | 1 | A |
| T | | | | | | | | 0 | C | | | | | | | | | C | | | | | | | | | C | | | | | | | | C | |
| R | | | | | | | | | K | | | | | | | | | K | | | | | | | | | K | | | | | | | | | K |

| | | | | | | | | | |
|---|---|---|---|---|---|---|---|---|---|
| X | 1 | 1 | 0 | 0 | 1 | 1 | 0 | N | S |
| | | | | | | | | A | T |
| | | | | | | | | K | P |

Example 6: An external SIB Master read from volume memory address 0x043 with expected data of 0x4C

SAD2 = SAD1 = 0

| | | | | | | | | | | | | | | | | | | | | | | | | | | | | | | | | | | | | |
|---|---|---|---|---|---|---|---|-----|---|---|---|---|---|---|---|---|---|---|---|---|---|---|---|---|---|---|---|---|---|---|---|---|---|---|---|---|
| S | 1 | 1 | 0 | 0 | 0 | 0 | 0 | R/W | A | 1 | 0 | 0 | 1 | 0 | 0 | 1 | 0 | A | 0 | 0 | 0 | 0 | 0 | 0 | 0 | 0 | A | 0 | 1 | 0 | 0 | 0 | 0 | 1 | 1 | A |
| T | | | | | | | | 0 | C | | | | | | | | | C | | | | | | | | | C | | | | | | | | C | |
| R | | | | | | | | | K | | | | | | | | | K | | | | | | | | | K | | | | | | | | | K |

| | | | | | | | | | | | | | | | | | | | |
|---|---|---|---|---|---|---|---|-----|---|---|---|---|---|---|---|---|---|---|---|
| R | 1 | 1 | 0 | 0 | 0 | 0 | 0 | R/W | A | 0 | 1 | 0 | 0 | 1 | 1 | 0 | 0 | N | S |
| S | | | | | | | | 1 | C | | | | | | | | A | T | |
| T | | | | | | | | | K | | | | | | | | K | P | |

The Data Length of each access is dependent on its intended location. An access to the register space or the volume space is a 1-byte access; an access to coefficient space is a 3-byte access; an access to the reserved space is a 6-byte access. If an access that is not the exact size occurs, then the QF3DFX SIB slave state machine will hang. It expects the exact number of bytes. Table 5-5 - Access Size, lists the byte size per access.

| Access | Access Size |
|-------------------------|--------------------|
| Configuration Registers | 1 byte (8 bits) |
| Coefficient Memory | 3 bytes (24 bits) |
| Volume Memory | 1 byte (7 bits) |
| Reserved Memory | 6 bytes (48 bits) |

Table 5-5 - Access Size

The length of the data access can be as long as the entire range of the register or memory map. It can be any size as long as it follows the access size rule. As an example, a write to coefficient memory can be any multiple of 3 bytes (i.e. 3, 6, 9, 12, 15, etc). It cannot be 4 bytes long. A write to register space or to volume memory can be 1, 2, 3, 4, 5 ... number of bytes long.

5.3 SIB Master/Boot

5.3.1 Introduction

The QF3DFX SIB Master has two functions:

- Access an external EEPROM during boot
- Complete a write or read from an external SPI master to an SIB slave device, primarily a EEPROM.

The Auto Loader can be used in place of a microcontroller to load a configuration (registers, reserved locations, coefficients, and volume) into the QF3DFX chip. The Auto Loader has the ability to detect if there is an EEPROM present or not. Once the EEPROM has been detected, the Auto Loader will do an atomic transfer of all the data.

An external SPI Master can access an external SIB EEPROM. This is described in detail in section 5.1, Serial Peripheral Interface (SPI) Protocol.

5.3.2 Auto Loader Features

- Atomically reads all of the data from the EEPROM and transfers it to the appropriate registers and coefficient memory locations.
- Supports standard EEPROM 16-bit addressing mode.
- Externally selectable primary target address of 0x50, 0x51, 0x52, and 0x53 (note: these device addresses are 7-bits wide, bit zero (LSb) of the actual 8-bit SIB address phase transfer is the read/write bit).
- Detects valid EEPROM device on bus and authenticates the QFT header contents prior to loading data.
- Supports loading data from any location based on starting address as loaded in the EEPROM header.
- Supports page turn and end-load instructions.

IMPORTANT: The SIB Master is not able to detect collisions with other SIB Masters during the Auto Load sequence. Because of this, multiple QF3DFX chips that sit on the same two SIB wires must be brought out of the reset individually and separated in time. Once the first QF3DFX is brought out of reset, the other QF3DFX chips (and any other SIB masters) must not be brought out of reset until the first QF3DFX has completed the Auto Load sequence. Bit 5 of the `BOOT_STATUS` register in the first QF3DFX chip will be set when it is done Auto Loading. Additional QF3DFX chips may then be brought out of reset in a similar fashion.

5.3.3 Supported EEPROM Characteristics:

- Supported EEPROMs include only devices that use 16-bit addressing. An example is the Microchip M24LC128 family.
- Fixed page/block sizes of 256 bytes for EEPROMs that require a new transfer on page boundaries for reads.
- The 16-bit type device addressing format consists of one EEPROM with multiple pages of 256 bytes at a single SIB address (some EEPROMs do not require paging for reads). A single 16-bit EEPROM can also be used by up to four QF3DFXs by using the SAD1 and SAD2 pins.
- Page turns are accomplished by changing the upper byte of the 16-bit address while the SIB address remains constant through entire address range.
- The device must have a base starting SIB address that is configurable to 0x50 through 0x53 (This is the unshifted, 7-bit address, where the four most significant bits are 1010b). A QF3DFX can access up to four devices by using the SAD1 and SAD2 pins to program the two LSB bits in the device address. The start address in the header or Page-turn instruction can point to a different page that is anywhere from 0x50 to 0x57 (Only the offset from 0 to 7 needs to be specified).
- SIB data bus speed should be limited to a maximum 400 kHz operation to facilitate slow cheap EEPROMs.

The reader must consult the EEPROM manufacturers' data sheets for complete details and correct timing information.

5.3.4 EEPROM Access Flow

The flow chart in Figure 2, Auto Loader Flow Chart, indicates the basic flow of the Auto Loader.

After reset, if enabled, the Auto Loader will arbitrate for the bus by writing out the slave address. If the Auto Loader is not granted the bus, it will continue to try until access is granted.

Once granted access, the Auto Loader will follow the slave address with an attempt to read portions of the header field of the EEPROM. The Auto Loader will compare locations 0x00, 0x01, and 0x02 to their expected contents ('Q', 'F', and 'T') and will compare the checksum at location 0x0F with its own calculation using the data from locations 0x00 – 0x06.

If the header information is found to be valid, then the Auto Loader will begin to read the EEPROM. Multiple atomic reads will continue until the EEPROM sends an instruction to begin on a new page or the EEPROM sends an instruction to end the access. If the instruction is a page-turn then the Auto Loader will begin the access by writing out the slave address followed by the new word address (the header reads do not repeat). If the instruction is a done-instruction then the auto reader will end the access and turn off until the next reset.

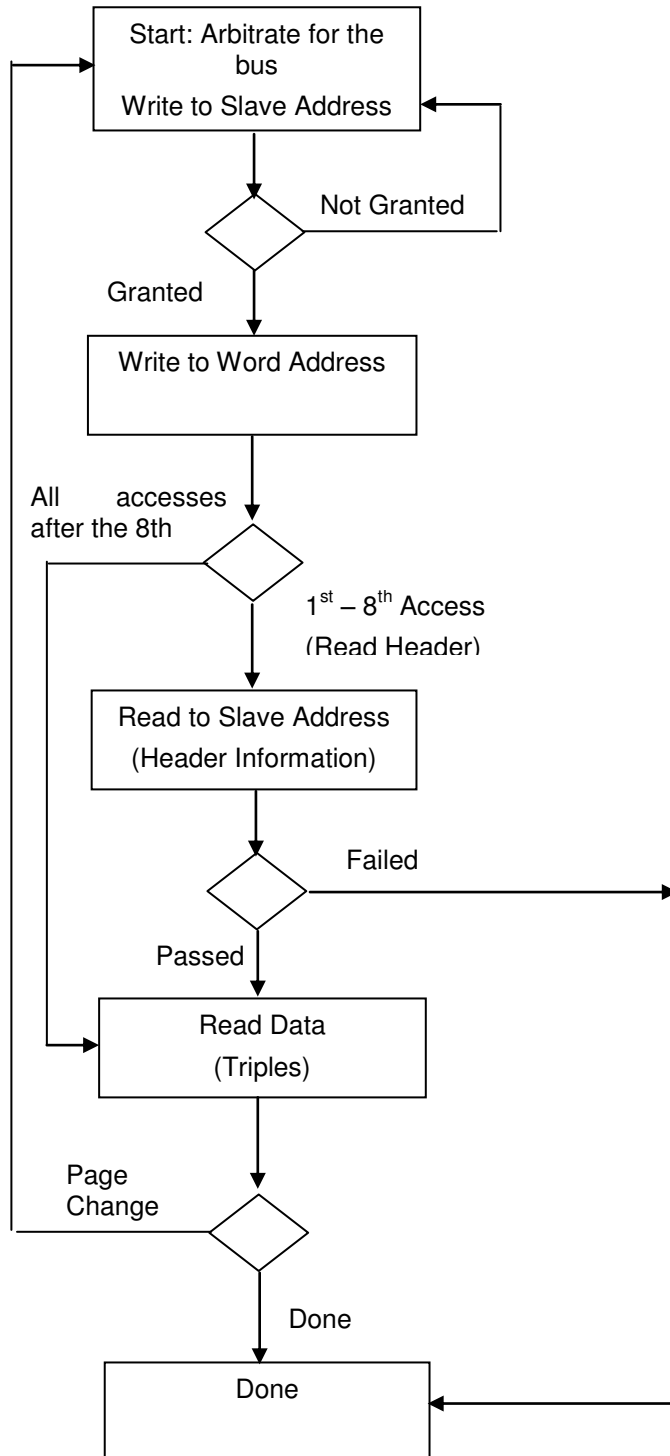

Figure 5-2: Auto Loader Flow Chart

5.3.5 EEPROM Header Format

Prior to importing data from an EEPROM, the contents are authenticated to ensure that the information in the EEPROM is valid. The authentication method ensures that the first three registers in the header contain the ASCII characters “QFT” and the last register contains a zero checksum calculated on the first 7 registers in the header.

The Auto Loader expects to find the EEPROM header beginning at the base location of an EEPROM located at either 0x50, 0x51, 0x52, or 0x53. The EEPROM header registers are always located starting at address 0x00 in the first page of EEPROM memory for address 0x50. The header information for the other addresses are located at an offset of 4k byte. The main purpose of this is to allow up to four QF3DFXs to share one EEPROM. The EEPROM starting address location for an address of 0x51 would be 0x800, for 0x52 it would be 0x1000, for 0x53 it would be 0x1800.

| Address | Name | Description | Value |
|---------|--------|--|------------|
| 00 | IDENQ | Contains the ASCII character “Q” as in Q uickfilter | 0x51 |
| 01 | IDENF | Contains the ASCII character “F” as in Quick F ilter | 0x46 |
| 02 | IDENT | Contains the ASCII character “T” as in T echnologies | 0x54 |
| 03 | ECFG | EEPROM Configuration <ul style="list-style-type: none"> • B7 is addressing type for memories • B6 is reserved • B5:0 contains page number of last location used | User Set |
| 04-12 | SAMSB | Starting Address of Most Significant Byte | User Set |
| 05-13 | SALSB | Starting Address of Least Significant Byte | User Set |
| 14 | REVNUM | Revision number of EEPROM Image <ul style="list-style-type: none"> • B7:4 is major revision number • B3:0 is minor revision number | User Set |
| 15 | EHCS | EEPROM Header zero check sum of registers 0x0 – 0x6 | Calculated |

Table 5-6: EEPROM Header Register Map

Identification Q Register

Address 0h

| Bit | D7 | D6 | D5 | D4 | D3 | D2 | D1 | D0 |
|----------|------------|----|----|----|----|----|----|----|
| Value | 0 | 1 | 0 | 1 | 0 | 0 | 0 | 1 |
| Mnemonic | IDENA(7:0) | | | | | | | |
| Access | RO | RO | RO | RO | RO | RO | RO | RO |

| Mnemonic | Description |
|----------|--|
| IDENA | Contains the ACSII character “Q” Must be properly decoded by the loader to continue |

Identification F Register
Address 1h

| | | | | | | | | |
|----------|------------|----|----|----|----|----|----|----|
| Bit | D7 | D6 | D5 | D4 | D3 | D2 | D1 | D0 |
| Value | 0 | 1 | 0 | 0 | 0 | 1 | 1 | 0 |
| Mnemonic | IDENT(7:0) | | | | | | | |
| Access | RO | RO | RO | RO | RO | RO | RO | RO |

| Mnemonic | Description |
|----------|--|
| IDENT | Contains the ACSII character "F" Must be properly decoded by the loader to continue |

Identification T Register
Address 2h

| | | | | | | | | |
|----------|------------|----|----|----|----|----|----|----|
| Bit | D7 | D6 | D5 | D4 | D3 | D2 | D1 | D0 |
| Value | 0 | 1 | 0 | 1 | 0 | 1 | 0 | 0 |
| Mnemonic | IDENI(7:0) | | | | | | | |
| Access | RO | RO | RO | RO | RO | RO | RO | RO |

| Mnemonic | Description |
|----------|--|
| IDENI | Contains the ACSII character "T" Must be properly decoded by the loader to continue |

EEPROM Configuration Register
Address 3h

| | | | | | | | | |
|----------|----------|------|----------|----|----|----|----|----|
| Bit | D7 | D6 | D5 | D4 | D3 | D2 | D1 | D0 |
| Value | User Set | | | | | | | |
| Mnemonic | AT | RSVD | LPU(5:0) | | | | | |
| Access | RW | RW | RW | RW | RW | RW | RW | RW |

| Mnemonic | Description |
|----------|--|
| AT | Addressing Type 1 = 16 bit Addressing mode. SIB must broadcast full address 0 = 8 bit Addressing mode. SIB broadcasts only 8 bit address |
| RSVD | Reserved. Returns 0 by default. |

Starting Address MSB Register
Address even 4h-12h

| | | | | | | | | |
|----------|------------|----|----|----|----|----|----|----|
| Bit | D7 | D6 | D5 | D4 | D3 | D2 | D1 | D0 |
| Value | User Set | | | | | | | |
| Mnemonic | SAMSB(7:0) | | | | | | | |
| Access | RW | RW | RW | RW | RW | RW | RW | RW |

| Mnemonic | Description |
|----------|---|
| SAMSB | <p>Contains the Starting Address MSB of the QF3DFX data. MSB in 16 bit addressing mode is used to access the appropriate memory page. For 8 bit addressing mode, it would be used to access the correct device by adding the value in this register to the initial device address of 0x50. For 8 bit device, the valid range is 0x00 to 0x07. There eight of these registers in each QF3DFX, but only one is used. The correct register for an individual QF3DFX is dependent on the state of the Slave address pins.</p> <p>A Slave Address of 000 would correspond to register 4h, A Slave Address of 111 would correspond to register 12h.</p> |

Starting Address LSB Register
Address 5h-13h

| | | | | | | | | |
|----------|------------|----|----|----|----|----|----|----|
| Bit | D7 | D6 | D5 | D4 | D3 | D2 | D1 | D0 |
| Value | User Set | | | | | | | |
| Mnemonic | SALSB(7:0) | | | | | | | |
| Access | RW | RW | RW | RW | RW | RW | RW | RW |

| Mnemonic | Description |
|----------|--|
| SALSB | <p>Contains the Starting Address LSB of the QF3DFX data. Normally the data will be found starting immediately after the EEPROM header. There eight of these registers in each QF3DFX, but only one is used. The correct register for an individual QF3DFX is dependent on the state of the Slave address pins.</p> <p>A Slave Address of 000 would correspond to register 5h, A Slave Address of 111 would correspond to register 13h.</p> |

EEPROM Image Data Revision Register
Address 14h

| | | | | | | | | |
|----------|------------|----|----|----|------------|----|----|----|
| Bit | D7 | D6 | D5 | D4 | D3 | D2 | D1 | D0 |
| Value | User Set | | | | | | | |
| Mnemonic | MJRRN(3:0) | | | | MNRRN(3:0) | | | |
| Access | RW | RW | RW | RW | RW | RW | RW | RW |

| Mnemonic | Description |
|----------|---|
| MJRRN | <p>Major Revision Number.</p> <p>These four bits are used to ID the image major revision. Unused by HW loader</p> <p>These bits are only used as part of the checksum calculation and are not accessible.</p> |

| | |
|-------|--|
| MNRRN | Minor Revision Number. These four bits are used to ID the image minor revision. Unused by HW loader These bits are only used as part of the checksum calculation and are not accessible. |
|-------|--|

EEPROM Header Checksum Register

Address 15h

| | | | | | | | | |
|----------|-----------|----|----|----|----|----|----|----|
| Bit | D7 | D6 | D5 | D4 | D3 | D2 | D1 | D0 |
| Value | User Set | | | | | | | |
| Mnemonic | EHCS(7:0) | | | | | | | |
| Access | RW | RW | RW | RW | RW | RW | RW | RW |

| Mnemonic | Description |
|----------|---|
| EHCS | Contains the value required to zero check sum, the EEPROM header data contained in registers 0x0 – 0x14. The value contained in this register should result in a sum equal to 0xX00 when added to the above header registers. If this occurs then the data load process will begin at the SAMSB\SALSB location. If no match occurs then the error flag will be set. The auto load will terminate. |

5.3.6 Data Format

Except for the header, all data in the EEPROM is aligned in groups of bytes called instructions. Instructions are broken down into several fields always beginning with an 8-bit opcode. The type of transfer is based on the opcode, as shown in the following table.

| Data Triple | Name | Description of Triple | YY value |
|---------------------|------|---|---------------|
| 82,yy,yy,zz,zz,data | DRA | Direct Register Addressing mode in QFT devices <ul style="list-style-type: none"> YY starting address (first register to be programmed) ZZ the number of registers to be programmed The data field is one or more 8-bit register data | 0x0000-0x01FF |
| 86,yy,yy,zz,zz,data | CMA | Coefficient Memory Addressing Mode Format <ul style="list-style-type: none"> YY is the starting address in coefficient memory ZZ is the number bytes of coefficient data to be read The data field is one or more 24-bit memory data in three 8-bit increments | 0x0000-0x01FF |
| FA,zz | PTI | Page turn instruction Mode Format <ul style="list-style-type: none"> Operands zz = 0x00 – 0xFE are jump to page zz and operand 0xFF is jump to next page | N.A. |
| FF,FF | SDL | Stop Data Load (normal termination mode) | X |
| | | | |

Table 5-7: EEPROM Instruction Formats

5.3.7 Direct Register Addressing mode

Direct Register Addressing mode directs the data in the EEPROM to one or more of the configuration registers. The first byte is the opcode, which indicates an access to the configuration registers. The second byte (yy) and the third byte (yy) delineate the starting address of the first register to be programmed. The fourth byte (zz) and fifth byte (zz) call out how many registers after the register indicated by the second byte will also be loaded. The subsequent bytes contain the data for the registers. The number of data bytes must match the number indicated in the fourth and fifth bytes.

Register Examples:

82,00,00,00,01,AA indicates the register zero will be programmed to a value of 0xAA.

82,00,00,00,10,AA,BB,CC, ... 23 indicates the register zero will be programmed along with the next 16 registers. Register 0 will be programmed to AA, register 1 to BB, ... register 15 to 0x23.

82,00,01,00,01,33 indicates that register one will be programmed to a value of 0x33.

82,00,01,00,08,11,22,33, ... ,88 indicates the register one will be programmed along with the next seven registers. Register 0 will be programmed to 0x11, register 2 to 22, ... , register 7 to 0x88.

5.3.8 Coefficient Addressing Mode Format

Coefficient Addressing Mode directs data from the EEPROM to one or more coefficient memory locations. The first byte is the opcode. The second and third bytes are the starting address. The fourth and fifth bytes are the number of bytes of coefficient data to be read (3 bytes per coefficient). The coefficient memory is three bytes wide, which means that the smallest value for the combination fourth and fifth bytes would be 0x03.

Coefficient Memory Examples:

86,00,00,00,03,11,22,33 indicates that the coefficient memory location 0 will be programmed with a value of 0x112233.

86,00,00,00,09,11,22,33, ... ,99 indicates that the coefficient memory location 0 will be programmed along the next 2 locations. This is a total of three memory locations: location 0 = 0x112233, location 1 = 0x445566, location 2 = 0x778899.

86,00,01,00,0C,11,22,33, ..., CC indicates that the coefficient memory location 1 will be programmed along with the next 3 locations. This is a total of four memory locations: location 1 = 0x112233, location 2 = 445566, location 3 = 778899, location 4 = AABBC.

5.3.9 Page turn instruction

A page turn will jump to the next 256-byte boundary or to the page directed as defined by zz.

5.3.10 Stop Data Load (normal termination mode)

This command will instruct the QF3DFX SIB master to initiate a Stop Command on the SIB bus.

5.3.11 Status Register

The BOOT_STATUS register is the only configuration register related to the Auto Loader. It is a status register that gives the status of the auto loading. It is a read only register.

6 DATA INTERFACE PROTOCOL

6.1 Introduction

The Data Formatter block handles serial / parallel conversion protocols for the input and output data streams.

On the input side, the Data Formatter will create the parallel data samples from the incoming serial stream on dSDI and separate them into left and right channels as appropriate. It will then present the samples to the Datapath Blocks for processing.

On the output side, the Data Formatter receives samples from up to five data streams coming from the Datapath Blocks and will apply them to the appropriate dSDOn serial streams as programmed.

6.2 Modes of Operation

The QF3DFX is designed to interface directly with a variety of Signal Processing Sources and Sinks. It supports I2S, Left Justified, Right Justified, and TDM serial protocols.

The QF3DFX is designed to work with data widths of 16 and 24 bits.

The QF3DFX supports both 2's complement and offset binary data formats. Data is always transmitted Most Significant Bit first.

6.2.1 I2S, Left-Justified, Right-Justified

Below is a table matching the Data Interface related pins with their functions and I2S names.

| Pin Name | Function | I2S Name |
|------------------|-------------------|-----------------|
| dSDI | Serial Data Input | SD (in) |
| dSDO1/2/3 | Serial Data Out | SD (out) |
| dCS | Framing Signal | WS |
| dSCK | Serial Clock | SCK |

Table 6-1 - Pin Names to I2S Names

The **dCS** input indicates which of two (usually left / right) time-division multiplexed data channels is being transmitted. The channels are transmitted alternately on the input data line (**SD** on the **dSDI** input) and are synchronized by a clock line (**SCK** on the **dSCK** input).

The three data protocols (I2S, Left Justified, and Right Justified) are determined by programming the **dsize** and **mode** bits in the DCONFIG register and the **hfs** bits in the HFRAME_SIZE register. For these protocols, the dCS period in dSCK clocks (frame size) must be known and stable. The dCS high time must be the same as the dCS low time. The Data Size must not exceed 1/2 the frame size (the number of clocks between successive rising or successive falling dCS (WS) edges. Below is a table explaining how the Data Offset and Data Size relate to the protocol.

| Protocol | Start of Frame | Fixed Data Offset from Start of Frame (clocks) | Data_Size (bits) |
|-----------------|--------------------|--|------------------|
| I2S | dCS <u>Falling</u> | 1 | 16/24 |
| Left-Justified | dCS <u>Rising</u> | 0 | 16/24 |
| Right-Justified | dCS <u>Rising</u> | Slot Size – Data Size | 16/24 |

In Figure 6-1 below, all three examples have a frame size of 56 clocks; HFRAME_SIZE must be set to half that, or 28 decimal. All three examples have a data size of 24 bits.

- The I2S Mode example has a fixed data offset of 1 clock from dCS falling and from dCS rising. The frame begins with dCS falling.
- The Left-Justified Mode example has a fixed data offset of 0 clocks from dCS rising and from dCS falling. The frame begins with dCS rising.
- The Right-Justified Mode example has a fixed data offset of 28-24=4 clocks from dCS rising and from dCS falling. The frame begins with dCS rising.



Figure 6-1: Data Interface Timing Diagram I2S/LJ/RJ

The QF3DFX always drives out data from the opposite clock edge that the data is sampled on.

The default operation is to capture data on the rising edge of **dSCK** and drive data on the falling edge of **dSCK** (also known as **SCK**), but this can be changed to capture on falling edge (and drive from the rising edge) by writing the **DCLK_POL** bit in the **DCONFIG** register.

The QF3DFX supports data widths of 16 and 24 bits.

The **FILT_EN** bit must be set to '1' in the **CONTROL** register to enable audio processing. The output stream on the **dSDOn** pin(s) will have the same format as the input stream coming in on the **dSDI** pin.

6.2.2 TDM Mode

TDM (Time Division Multiplexed) Mode is a serial protocol where more than two channels can be placed onto a single wire. A frame (set of samples corresponding to a single point in time) is typically composed of 256 bit-clocks. These clocks are broken into eight groups called slots, each slot consisting of 32 clocks. A data sample sits somewhere within each slot. In TDM Mode, only dSDO1 is used; dSDO2 and dSDO3 are held low.

TDM uses either the rising or falling edge of the framing signal, dCS, to indicate the start of a frame of TDM data. The active edge of dCS is determined by the **dcs_pol** bit in the DCONFIG register. Because only a single edge is used to determine the start of a frame, the dCS signal can be any integral number of bit-clocks wide, from 1 to (frame_length-1).

The HFRAME_SIZE register determines how many clocks are in the frame.

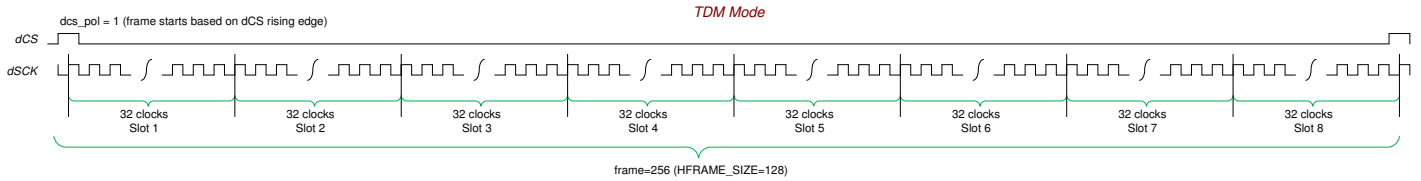

Figure 6-2 - TDM Mode Timing, All Slots

Each data sample sits within a slot. The offset from the start of the slot to the start of the data is determined by the OFFSET1-8 registers; the register name indicating which slot it will provide an offset for. Below are three examples showing timing for Slot 1 (requiring the OFFSET1 register to be set as shown).

TDM Mode – Slot 1, OFFSET1 = 0, dCS Active Edge = Rising

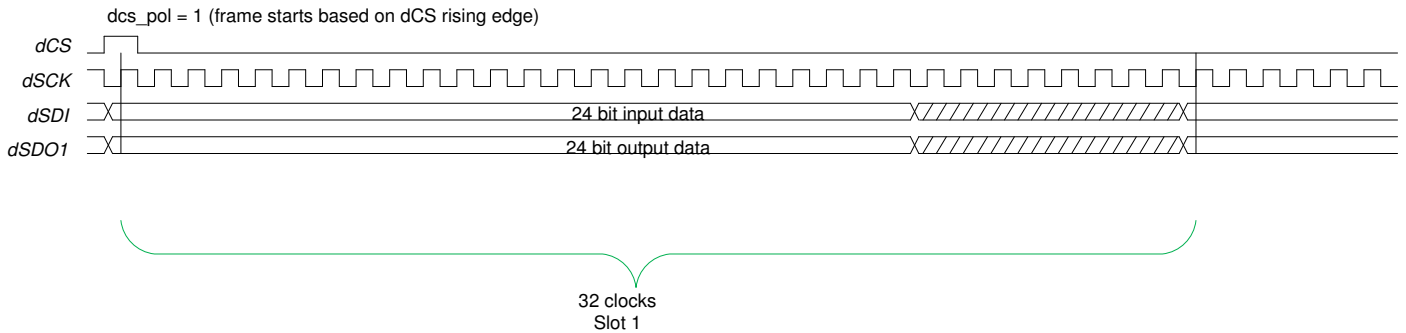

Figure 6-3 - TDM Mode Timing, Slot 1, Offset=0

TDM Mode – Slot 1, OFFSET1 = 1, dCS Active Edge = Falling

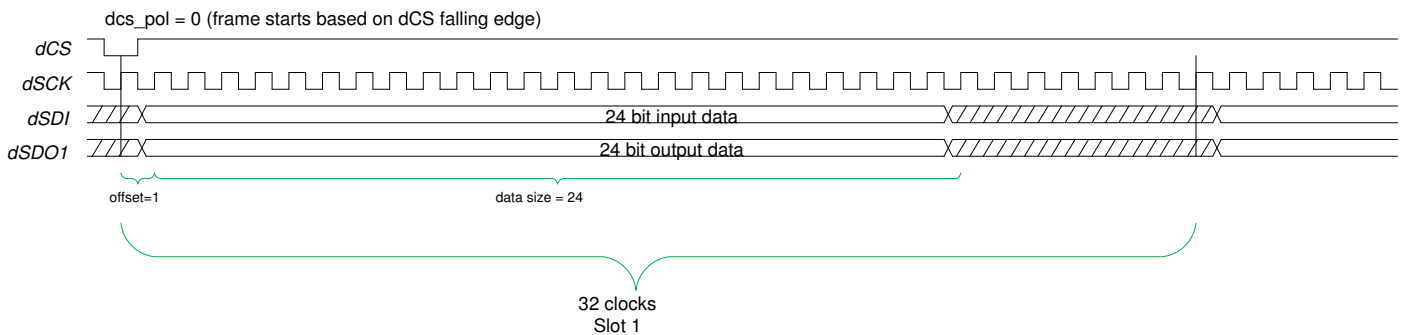

Figure 6-4 - TDM Mode Timing, Slot 1, Offset=1

TDM Mode – Slot 1, OFFSET1 = 8, dCS Active Edge = Falling

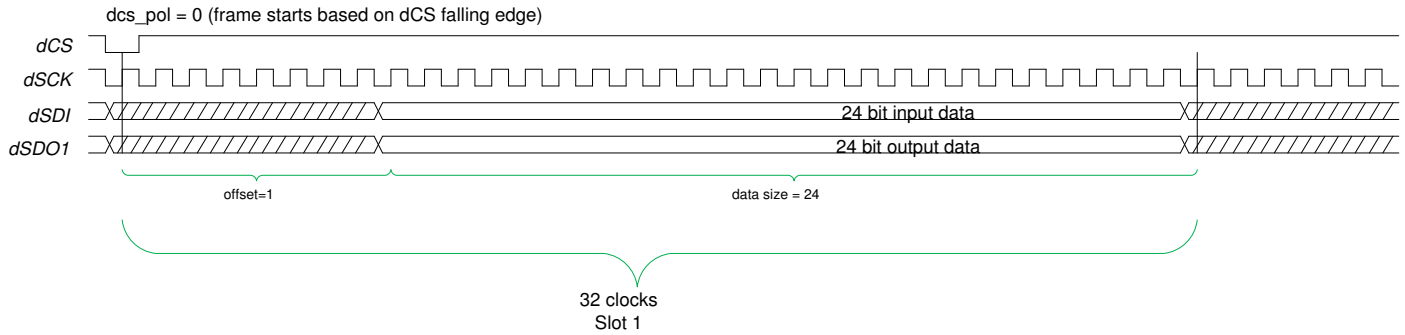

Figure 6-5 - TDM Mode Timing, Slot 1, Offset=8

Each succeeding OFFSETn register must contain the sum of the Slots before it plus the offset of the data sample within its own Slot.

With the flexibility of the OFFSETn and HFRAME_SIZE registers, non-standard TDM protocols can be supported (Frame Sizes that aren't equal to 256 or Slot Sizes that aren't 32-bits long).

The **pass_thru** bit in the DCONFIG register controls dSDO1 behavior during all bits when it is not driving Slot data generated by the QF3DFX chip. If it is a zero, dSDO1 tristates during this time. If it is a one, dSDO1 will asynchronously pass through whatever is on dSDI. This permits devices or channels not processed by the QF3DFX to have data passed along on the TDM bus, even though the QF3DFX isn't directly involved in the signal processing. Care must be taken that overall system timing is still met.

6.3 Input Mixer

All of the input channels / slots are able to contribute to each of the three internal audio channels (2 satellites, 1 SW/Ce). The very first stage of the QF3DFX signal processing path creates a weighted sum for each of the three internal audio channels. Each weighted sum is created by multiplying each input channel / slot by a unique constant value, and then summing all of them. QFPro provides easy assignment of all of these constants. Refer to the figure below for a pictorial representation.

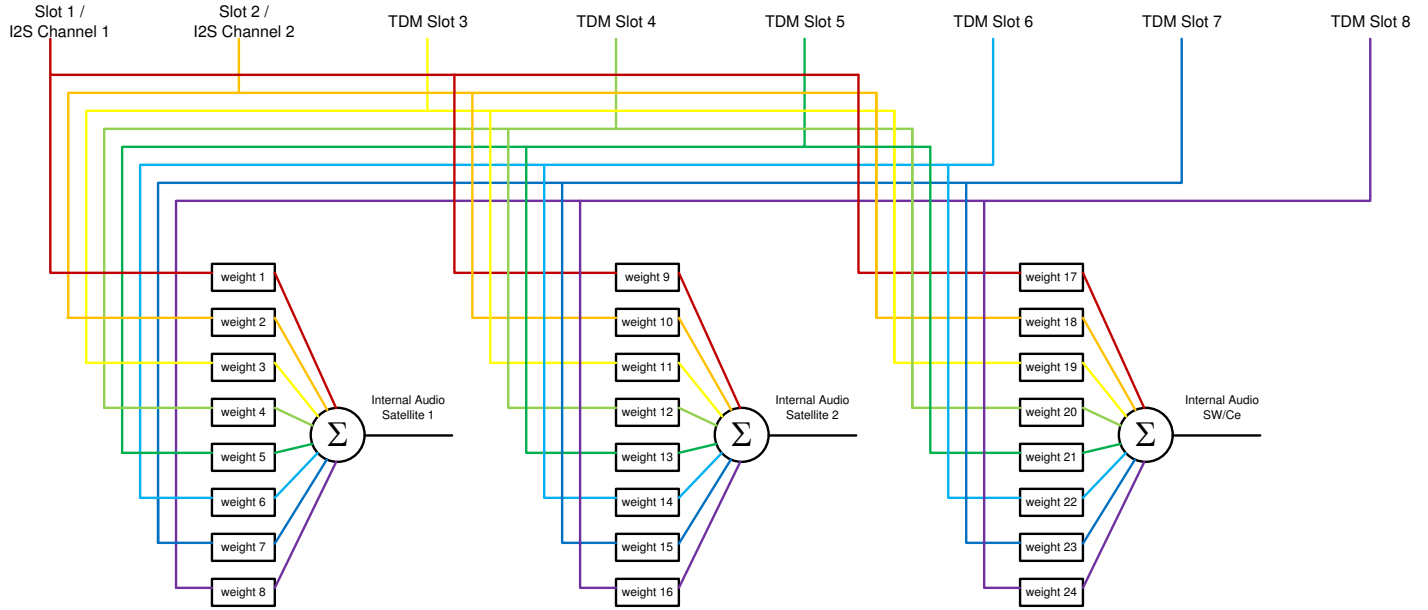

Figure 6-6 - Input Channel Scaling

6.4 Output Mixer

The Output Mixer assigns each of the output slots with one of the five audio streams from the core. There is no restriction on how the audio streams get assigned. A single audio stream may get assigned to zero, one, many, or all output slots/channels. QFPro provides easy assignment of these internal audio channels to output slots. Refer to the DOUT12_MAP registers for more detailed information.

| TDM (dSDO1) | I2S/LJ/RJ | Register | Field |
|-------------|----------------|------------|----------------|
| Slot 1 | dSDO1 Left | DOUT12_MAP | slot1_src[2:0] |
| Slot 2 | dSDO1 Right | DOUT12_MAP | slot2_src[2:0] |
| Slot 3 | dSDO2 Left | DOUT34_MAP | slot3_src[2:0] |
| Slot 4 | dSDO2 Right | DOUT34_MAP | slot4_src[2:0] |
| Slot 5 | dSDO3 Left | DOUT56_MAP | slot5_src[2:0] |
| Slot 6 | dSDO3 Right | DOUT56_MAP | slot5_src[2:0] |
| Slot 7 | Not Applicable | DOUT78_MAP | slot6_src[2:0] |
| Slot 8 | Not Applicable | DOUT78_MAP | slot7_src[2:0] |

Table 6-2 - Register FieldTo Output Channel Map

6.5 dSDOn Output Enable Logic

6.5.1 DIN_PT Control

At times it may be desirable to pass the data present at **dSDI** directly to the **dSDOn** outputs.

If the **din_pt** cfg bit in the CONTROL register is set, **dSDI** will pass asynchronously through to **dSDOn** (albeit delayed by a few nanoseconds).

This control bit overrides all other settings for **dSDOn** and should be set to 0 when either configuring the chip or processing data.

6.5.2 FILT_EN Control

While the chips memories are being written to, **filt_en** must be set to a zero. During this time, if **din_pt=0**, all **dSDOn** outputs will be tristated. To enable signal processing, set **filt_en** to a one. The **dSDOn** pins will be driven then (depending on the following sections).

6.5.3 Normal Operation

6.5.3.1 dSDO1

Once **din_pt=0** and **filt_en=1**, **dSDO1** will:

- Drive internally processed data OR
- Drive data passed from **dSDI** unchanged OR
- Be tristated

With **din_pt=0** and **filt_en=1**, the **dSDO1** will drive out everywhere where there should be valid data coming from QF3DFX based on the selected protocols.

In the protocol sequence where there is no valid data to be driven:

- If `pass_thru=0`, the output will tristate. The pin can be driven weakly low or high, if desired, through the `IO_dSDO1` config register.
- If `pass_thru=1`, the input will pass through to the output, incurring a few nanoseconds of delay..

6.5.3.2 *dSDO2 and dSDO3*

Unlike `dSDO1`, once `din_pt=0` and `filt_en=1`, `dSDO2` and `dSDO3` will always be driven with either internally processed data (during times when valid data is expected within the frame) or zero's (during the time within a frame where no valid data is expected).

7 CONFIGURATION REGISTERS

7.1 Register Summary

| Addr | Name | Description |
|------|----------------|------------------------------------|
| 00h | TEST_RW | Software Test; Reads & Writes |
| 01h | CHIP_ID | Chip ID Number |
| 02h | VERSION | Chip Version Number |
| 03h | CONTROL | Mode Control |
| 04h | DCONFIG | Data Format Control |
| 05h | HFRAME_SIZE | Half Frame Size |
| 06h | OFFSET1 | Data Offset to Channel / Slot 1 |
| 07h | OFFSET2 | Data Offset to Channel / Slot 2 |
| 08h | OFFSET3 | Data Offset to Slot 3 |
| 09h | OFFSET4 | Data Offset to Slot 4 |
| 0Ah | OFFSET5 | Data Offset to Slot 5 |
| 0Bh | OFFSET6 | Data Offset to Slot 6 |
| 0Ch | OFFSET7 | Data Offset to Slot 7 |
| 0Dh | OFFSET8 | Data Offset to Slot 8 |
| 13h | DOUT12_MAP | Output Channel/Slot Assignment 1,2 |
| 14h | DOUT34_MAP | Output Channel/Slot Assignment 3,4 |
| 15h | DOUT56_MAP | Output Channel/Slot Assignment 5,6 |
| 16h | DOUT78_MAP | Output Channel/Slot Assignment 7,8 |
| 17h | AGCS_THR_HI | Satellite AGC High Threshold |
| 18h | AGCS_THR_LO | Satellite AGC Low Threshold |
| 19h | AGCS_THR_NO | Satellite AGC Noise Threshold |
| 1Ah | AGCS_ATTACK | Satellite AGC Attack Rate |
| 1Ch | AGCS_RELEASE | Satellite AGC Release Rate |
| 1Eh | AGCS_ALPHA | Satellite AGC Alpha |
| 1Fh | AGCM_THR_HI | Mono AGC High Threshold |
| 20h | AGCM_THR_LO | Mono AGC Low Threshold |
| 21h | AGCM_THR_NO | Mono AGC Noise Threshold |
| 22h | AGCM_ATTACK | Mono AGC Attack Rate |
| 24h | AGCM_RELEASE | Mono AGC Release Rate |
| 26h | AGCM_ALPHA | Mono AGC Alpha |
| 28h | GEQ_P1_F1_GAIN | GEQ Profile 1 Filter 1 Gain |
| 29h | GEQ_P1_F2_GAIN | GEQ Profile 1 Filter 2 Gain |
| 2Ah | GEQ_P1_F3_GAIN | GEQ Profile 1 Filter 3 Gain |

| Addr | Name | Description |
|------|----------------|-----------------------------|
| 2Bh | GEQ_P1_F4_GAIN | GEQ Profile 1 Filter 4 Gain |
| 2Ch | GEQ_P1_F5_GAIN | GEQ Profile 1 Filter 5 Gain |
| 2Dh | GEQ_P2_F1_GAIN | GEQ Profile 2 Filter 1 Gain |
| 2Eh | GEQ_P2_F2_GAIN | GEQ Profile 2 Filter 2 Gain |
| 2Fh | GEQ_P2_F3_GAIN | GEQ Profile 2 Filter 3 Gain |
| 30h | GEQ_P2_F4_GAIN | GEQ Profile 2 Filter 4 Gain |
| 31h | GEQ_P2_F5_GAIN | GEQ Profile 2 Filter 5 Gain |
| 32h | GEQ_P3_F1_GAIN | GEQ Profile 3 Filter 1 Gain |
| 33h | GEQ_P3_F2_GAIN | GEQ Profile 3 Filter 2 Gain |
| 34h | GEQ_P3_F3_GAIN | GEQ Profile 3 Filter 3 Gain |
| 35h | GEQ_P3_F4_GAIN | GEQ Profile 3 Filter 4 Gain |
| 36h | GEQ_P3_F5_GAIN | GEQ Profile 3 Filter 5 Gain |
| 37h | GEQ_P4_F1_GAIN | GEQ Profile 4 Filter 1 Gain |
| 38h | GEQ_P4_F2_GAIN | GEQ Profile 4 Filter 2 Gain |
| 39h | GEQ_P4_F3_GAIN | GEQ Profile 4 Filter 3 Gain |
| 3Ah | GEQ_P4_F4_GAIN | GEQ Profile 4 Filter 4 Gain |
| 3Bh | GEQ_P4_F5_GAIN | GEQ Profile 4 Filter 5 Gain |
| 3Ch | GEQ_P5_F1_GAIN | GEQ Profile 5 Filter 1 Gain |
| 3Dh | GEQ_P5_F2_GAIN | GEQ Profile 5 Filter 2 Gain |
| 3Eh | GEQ_P5_F3_GAIN | GEQ Profile 5 Filter 3 Gain |
| 3Fh | GEQ_P5_F4_GAIN | GEQ Profile 5 Filter 4 Gain |
| 40h | GEQ_P5_F5_GAIN | GEQ Profile 5 Filter 5 Gain |
| 41h | GEQ_P6_F1_GAIN | GEQ Profile 6 Filter 1 Gain |
| 42h | GEQ_P6_F2_GAIN | GEQ Profile 6 Filter 2 Gain |
| 43h | GEQ_P6_F3_GAIN | GEQ Profile 6 Filter 3 Gain |
| 44h | GEQ_P6_F4_GAIN | GEQ Profile 6 Filter 4 Gain |
| 45h | GEQ_P6_F5_GAIN | GEQ Profile 6 Filter 5 Gain |
| 46h | GEQ_P7_F1_GAIN | GEQ Profile 7 Filter 1 Gain |
| 47h | GEQ_P7_F2_GAIN | GEQ Profile 7 Filter 2 Gain |
| 48h | GEQ_P7_F3_GAIN | GEQ Profile 7 Filter 3 Gain |
| 49h | GEQ_P7_F4_GAIN | GEQ Profile 7 Filter 4 Gain |
| 4Ah | GEQ_P7_F5_GAIN | GEQ Profile 7 Filter 5 Gain |
| 4Bh | GEQ_P8_F1_GAIN | GEQ Profile 8 Filter 1 Gain |

| Addr | Name | Description |
|------|----------------|--------------------------------|
| 4Ch | GEQ_P8_F2_GAIN | GEQ Profile 8 Filter 2 Gain |
| 4Dh | GEQ_P8_F3_GAIN | GEQ Profile 8 Filter 3 Gain |
| 4Eh | GEQ_P8_F4_GAIN | GEQ Profile 8 Filter 4 Gain |
| 4Fh | GEQ_P8_F5_GAIN | GEQ Profile 8 Filter 5 Gain |
| 50h | DYB_THR_HI | Dynamic Bass High Threshold |
| 51h | DYB_THR_NO | Dynamic Bass Noise Threshold |
| 52h | DYB_MAX_GAIN | Dynamic Bass Maximum Gain |
| 53h | DYB_TRACK | Dynamic Bass Tracking Rate |
| 54h | DYT_THR_HI | Dynamic Treble High Threshold |
| 55h | DYT_THR_NO | Dynamic Treble Noise Threshold |
| 56h | DYT_MAX_GAIN | Dynamic Treble Maximum Gain |
| 57h | DYT_TRACK | Dynamic Treble Tracking Rate |
| 58h | SPI_TO_I2C | SPI to 2C Status |
| 59h | I2C_RDATA | I2C Read Data |
| 5Ah | BOOT_STATUS | I2C Boot Status |
| 5Bh | PRO_VOL_HADDR | Profile Volume High Address |
| 5Ch | PRO_VOL_LADDR | Profile Volume Low Address |
| 5Dh | PRO_CTRL | Master Profile Control |
| 5Eh | CUR_VOL | Master Profile Volume |
| 5Fh | MAX_VOL | Maximum Master Volume |
| 60h | VSLEW | Profile Volume Slew Rate |
| 62h | BTNCTRL | Button and Tone Control |

| Addr | Name | Description |
|------|--------------|---|
| 63h | AMP_DROP | Amplifier Protection |
| 64h | TONE_GEN | Tone Control |
| 89h | IO_DSCK | Data Clock Pin Control, dSCK |
| 8Ah | IO_DCS | Data Chip Select Pin Control, dCS |
| 8Bh | IO_DS DI | I2S/TDM Data In Pin Control, dSDI |
| 8Ch | IO_CS_N | Configuration Chip Select Pin Control, cCSn |
| 8Dh | IO_SCLK | Configuration Clock Pin Control, cSCK |
| 8Eh | IO_SDI | SPI In Pin Control, cSDI |
| 8Fh | IO_SAD1 | I2C Address 1 Pin Control, cSAD1 |
| 90h | IO_SAD2 | I2C Address 2 Pin Control, cSAD2 |
| 91h | IO_VUP & VDN | Volume Up Pin Control, VUP & VDN |
| 92h | NA1 | Not used |
| 93h | IO_PRO | Profile Pin Control, PROF |
| 94h | IO_AMP | Amp Pin Control, AMP |
| 95h | IO_MUTE | Mute Pin Control, MUTE |
| 96h | IO_SCL | I2C SCL Pin Control, cSCL |
| 97h | IO_SDA | I2C SDA Pin Control, cSDA |
| 98h | IO_SDO | Configuration Output Pin Control, SDO |
| 99h | IO_DS DO1 | Data Output 1 Pin Control, dSDO1 |
| 9Ah | IO_DS DO2 | Data Output 2 Pin Control, dSDO2 |
| 9Bh | IO_DS DO3 | Data Output 3 Pin Control, dSDO3 |

Table 7-1 - Register Summary

7.2 Register Definitions

Access the configuration registers using the SPI or I2C protocol as described in Section 4

WARNING Do not write to any addresses not shown here.

00h TEST_RW - Software Test; Reads and Writes

| | Bit 7 | Bit 6 | Bit 5 | Bit 4 | Bit 3 | Bit 2 | Bit 1 | Bit 0 |
|--------|---|-------|-------|-------|-------|-------|-------|-------|
| POR | 0 | 0 | 0 | 0 | 0 | 0 | 0 | 0 |
| Access | RW | RW | RW | RW | RW | RW | RW | RW |
| Bits | TEST | | | | | | | |
| TEST | Provided as a developer debug read and write test register. | | | | | | | |

01h CHIP_ID - Chip ID Number

| | Bit 7 | Bit 6 | Bit 5 | Bit 4 | Bit 3 | Bit 2 | Bit 1 | Bit 0 |
|--------|---|-------|-------|-------|-------|-------|-------|-------|
| POR | 1 | 1 | 0 | 1 | 0 | 0 | 0 | 0 |
| Access | RO | RO | RO | RO | RO | RO | RO | RO |
| Bits | id | | | | | | | |
| id | Read-only byte containing the identification number for the QF3DFX device, D0h. | | | | | | | |

02h VERSION - Chip Version Number

| | Bit 7 | Bit 6 | Bit 5 | Bit 4 | Bit 3 | Bit 2 | Bit 1 | Bit 0 |
|--------|--|-------|-------|-------|-------|-------|-------|-------|
| POR | 0 | 0 | 0 | 0 | 0 | 0 | 1 | 0 |
| Access | RO | RO | RO | RO | RO | RO | RO | RO |
| Bits | ver | | | | | | | |
| ver | Read-only byte containing the version number for the QF3DFX device, 01h. | | | | | | | |

03h CONTROL - Mode Control

| | Bit 7 | Bit 6 | Bit 5 | Bit 4 | Bit 3 | Bit 2 | Bit 1 | Bit 0 |
|---------|--|-------|-------|-------|-------|-------|--------|---------|
| POR | 0 | 0 | 0 | 0 | 0 | 0 | 0 | 0 |
| Access | RO | RO | RO | RO | RO | RO | RW | RW |
| Bits | R | R | R | R | R | R | din_pt | filt_en |
| din_pt | Data In Pass Through (din_pt) : Puts the QF3DFX in Bypass mode 0 = Normal operation - dSDOn pins output the internal signal path data. 1 = Data pass through (asynchronous flow-through) - dSDOn pins output the data on the dSDI pin | | | | | | | |
| filt_en | Filter Enable (filt_en) : Enable the signal processing blocks and data path 0 = Configuration mode, signal processing disabled, access unlimited – access to all memory spaces. In this mode the dSDOn outputs are tristated. 1 = Filter mode, signal processing enabled, access limited to configuration and volume space only | | | | | | | |

04h DCONFIG - Data Format Control

| | Bit 7 | Bit 6 | Bit 5 | Bit 4 | Bit 3 | Bit 2 | Bit 1 | Bit 0 |
|------------------|--|--------------|------------------|-------------|-------|---------------|----------------|-----------------|
| POR | 0 | 1 | 1 | 0 | 0 | 0 | 0 | 1 |
| Access | RO | RW | RW | RW | RW | RW | RW | RW |
| Bits | R | dsize | pass_thru | mode | | format | dcs_pol | dsck_pol |
| dsize | Sets the data width 0 = 16-bit 1 = 24-bit | | | | | | | |
| pass_thru | In TDM Mode, determines how dSDO1 behaves during bit-clocks in a frame when it is not driving valid 16-bit or 24-bit data. This field is ignored in I2S, Left Justified, and Right Justified modes. 0 = dSDO1 tristates when not driving valid data. 1 = dSDO1 drives all of the time. Incoming dSDI passes asynchronously through the chip to dSDO1 when the chip is not driving valid 16-bit or 24-bit data. | | | | | | | |
| mode | Selects the data input mode. 00 = I2S 01 = Left Justified 10 = Right Justified 11 = TDM (Time Division Multiplexed) | | | | | | | |
| format | Selects the data format of the incoming data. This field is ignored in I2S, Left Justified, and Right Justified modes. 0 = Incoming data format is 2's complement. 1 = Incoming data format is offset binary. | | | | | | | |
| dcs_pol | Selects the edge of dCS that defines the start of a frame (one complete sample period) of data. This field is ignored in I2S, Left Justified, and Right Justified modes. 0 = The start of a frame is based from the falling edge of dCS_POL. 1 = The start of a frame is based from the rising edge of dCS_POL.. | | | | | | | |
| dsck_pol | The clock edge of dSCK on which the dSDI data is captured. dSDO is output on the opposite edge. 0 = dSDI data is captured on the falling edge of dSCK. 1 = dSDI data is captured on the rising edge of dSCK. | | | | | | | |

05h HFRAME_SIZE - Half Frame Size

| | Bit 7 | Bit 6 | Bit 5 | Bit 4 | Bit 3 | Bit 2 | Bit 1 | Bit 0 |
|------------|---|-------|-------|-------|-------|-------|-------|-------|
| POR | 0 | 0 | 1 | 0 | 0 | 0 | 0 | 0 |
| Access | RW | RW | RW | RW | RW | RW | RW | RW |
| Bits | hfs | | | | | | | |
| hfs | This field must be set to $\frac{1}{2}$ the number of bit clocks in a sample frame. This applies to all four transfer protocols (I2S, LJ, RJ, and TDM). For example, in a system where the I2S frame contains two 32-bit slots, this register must be programmed to $64 * \frac{1}{2} = 32$ decimal (20 hex). Frames sizes above 510 are not supported, as this would require a Half Frame Size greater than 255 decimal. | | | | | | | |

06h – 0Dh OFFSET1-8 - Data Offset to Channel / Slot

| Address Channel, Slot | POR | | | | | | | |
|-----------------------------|--|-------|-------|-------|-------|-------|-------|-------|
| | Bit 7 | Bit 6 | Bit 5 | Bit 4 | Bit 3 | Bit 2 | Bit 1 | Bit 0 |
| 06h, 1 | 0 | 0 | 0 | 0 | 0 | 0 | 0 | 1 |
| 07h, 2 | 0 | 0 | 1 | 0 | 0 | 0 | 0 | 1 |
| 08h, 3 | 0 | 1 | 0 | 0 | 0 | 0 | 0 | 1 |
| 09h, 4 | 0 | 1 | 1 | 0 | 0 | 0 | 0 | 1 |
| 0Ah, 5 | 1 | 0 | 0 | 0 | 0 | 0 | 0 | 1 |
| 0Bh, 6 | 1 | 0 | 1 | 0 | 0 | 0 | 0 | 1 |
| 0Ch, 7 | 1 | 1 | 0 | 0 | 0 | 0 | 0 | 1 |
| 0Dh, 8 | 1 | 1 | 1 | 0 | 0 | 0 | 0 | 1 |
| Access | RW | RW | RW | RW | RW | RW | RW | RW |
| Bits | doffset | | | | | | | |
| doffset | In TDM Mode, determines the offset to the start of data samples within a frame when. The first bit sampled after the active dCS edge has an offset of 0. Normally, adjacent slot's data offsets will differ by the slot size (e.g. with a slot size of 32. Up to eight slot offsets can be programmed. POR values are appropriate for TDM where the Most Significant Bit is offset by one bit clock from the start of each slot within the frame, with a slot size of 32 bit-clocks. These fields are ignored when the MODE bits are not set to TDM. These fields are ignored in I2S, Left Justified, and Right Justified modes. | | | | | | | |

13h – 16h DOUT12_MAP, DOUT34_MAP, DOUT56_MAP, DOUT78_MAP - Output Channel / Slot Assignments

| | Bit 7 | Bit 6 | Bit 5 | Bit 4 | Bit 3 | Bit 2 | Bit 1 | Bit 0 |
|--|--|-------|------------------|-------|-------|------------------|-------|-------|
| 13h, POR | 0 | 0 | 0 | 1 | 1 | 0 | 0 | 0 |
| 14h – 16h, POR | 0 | 0 | 1 | 1 | 1 | 1 | 1 | 1 |
| Access | RO | RO | RW | RW | RW | RW | RW | RW |
| 13h | R | R | slot2_src | | | slot1_src | | |
| 14h | R | R | slot4_src | | | slot3_src | | |
| 15h | R | R | slot6_src | | | slot5_src | | |
| 16h | R | R | slot8_src | | | slot7_src | | |
| slot1_src slot2_src slot3_src slot4_src slot5_src slot6_src slot7_src slot8_src | <p>Assigns an internal channel to an output slot 000 = Satellite channel 1 or Satellite channel 1 low 001 = Mono channel 010 = Satellite channel 1 high 011 = Satellite channel 2 or satellite channel 2 low 100 = Not used 101 = Satellite channel 2 high 110 = No assignment (output slot is disabled) 111 = No assignment (output slot is disabled)</p> <p>In TDM Mode, if an output slot is disabled, the data on that slot is determined by the pass_thru field in the Data Format Control register.</p> | | | | | | | |

17h AGCS_THR_HI - Satellite AGC High Threshold

1Fh AGCM_THR_HI - Mono AGC High Threshold

| | Bit 7 | Bit 6 | Bit 5 | Bit 4 | Bit 3 | Bit 2 | Bit 1 | Bit 0 |
|--|--|-------------------|-------|-------|-------|-------|-------|-------|
| POR | 0 | 0 | 0 | 0 | 0 | 0 | 0 | 0 |
| Access | RO | RW | RW | RW | RW | RW | RW | RW |
| 17h | R | sat_thr_hi | | | | | | |
| 1Fh | R | mon_thr_hi | | | | | | |
| sat_thr_hi mon_thr_hi | AGC High threshold These represent an average amplitude level measured in dB down from Digital Full Scale (dBFS) according to the following formula. High Threshold in dBFS = $-2 * \text{sat_thr_hi}$ (or mon_thr_hi) For example, if sat_thr_hi = 13 decimal, the Satellite AGC High Threshold is $-2*13 = -26$ dBFS Values of 73 and above (equating to -146 dBFS and lower) equate to exactly zero amplitude (-dBFS). There is lower precision at very low dBFS values (below -128 dBFS). Unpredictable results may occur if the sat_thr_hi value is less than the Satellite AGC Low Threshold (sat_thr_lo) or the Satellite AGC Noise Threshold (sat_thr_no). The same is true for mon_thr_hi with mon_thr_lo and mon_thr_no . | | | | | | | |

18h AGCS_THR_LO - Satellite AGC Low Threshold

20h AGCM_THR_LO - Mono AGC Low Threshold

| | Bit 7 | Bit 6 | Bit 5 | Bit 4 | Bit 3 | Bit 2 | Bit 1 | Bit 0 |
|--|---|-------------------|-------|-------|-------|-------|-------|-------|
| POR | 0 | 0 | 0 | 0 | 0 | 0 | 0 | 0 |
| Access | RO | RW | RW | RW | RW | RW | RW | RW |
| 18h | R | sat_thr_lo | | | | | | |
| 20h | R | mon_thr_lo | | | | | | |
| sat_thr_lo mon_thr_lo | AGC Low Threshold These represent an average amplitude level measured in dB down from Digital Full Scale (dBFS) according to the following formula. Low Threshold in dBFS = $-2 * \text{sat_thr_lo}$ (or mon_thr_lo) For example, if sat_thr_lo = 24 decimal, the low threshold is $-2*24 = -48$ dBFS Values for this register of 73 and above (equating to -146 dBFS and lower) equate to exactly zero amplitude (-dBFS). There is lower precision at very low dBFS values (below -128 dBFS). Unpredictable results may occur if the Satellite AGC Low Threshold (sat_thr_lo) is greater than the Satellite AGC High Threshold (sat_thr_hi) or less than the Satellite AGC Noise Threshold (sat_thr_no). The same is true for mon_thr_lo with mon_thr_hi and mon_thr_no . | | | | | | | |

19h AGCS_THR_NO - Satellite AGC Noise Threshold

21h AGCM_THR_NO - Mono AGC Noise Threshold

| | Bit 7 | Bit 6 | Bit 5 | Bit 4 | Bit 3 | Bit 2 | Bit 1 | Bit 0 |
|--|---|-------------------|-------|-------|-------|-------|-------|-------|
| POR | 0 | 0 | 0 | 0 | 0 | 0 | 0 | 0 |
| Access | RO | RW | RW | RW | RW | RW | RW | RW |
| 19h | R | sat_thr_no | | | | | | |
| 21h | R | mon_thr_no | | | | | | |
| sat_thr_no mon_thr_no | AGC noise threshold These represent an average amplitude level measured in dB down from Digital Full Scale (dBFS) according to the following formula. Noise Threshold in dBFS = $-2 * \text{sat_thr_no}$ (or mon_thr_no) For example, if sat_thr_no = 40 decimal, the low threshold is $-2*40 = -80$ dBFS Values for this register of 73 and above (equating to -146 dBFS and lower) equate to exactly zero amplitude (-dBFS). There is lower precision at very low dBFS values (below -128 dBFS). Unpredictable results may occur if the Satellite AGC Noise Threshold (sat_thr_no) is greater than the Satellite AGC High Threshold (sat_thr_hi) or the Satellite AGC Low Threshold (sat_thr_lo). The same is true for mon_thr_no with mon_thr_hi and mon_thr_lo . | | | | | | | |

1Ah/1Bh AGCS_ATTACK - Satellite AGC Attack Rate

1Fh/20h AGCM_ATTACK - Mono AGC Attack Rate

| | Bit 15 | Bit 14 | Bit 13 | Bit 12 | Bit 11 | Bit 10 | Bit 9 | Bit 8 |
|----------------------------|--|--------|--------|--------|--------|--------|-------|-------|
| POR | 0 | 0 | 0 | 0 | 0 | 0 | 0 | 0 |
| Access | RW | RW | RW | RW | RW | RW | RW | RW |
| 1Ah | satk[7:0] | | | | | | | |
| 1Bh | satk[15:8] | | | | | | | |
| 1Fh | matk[7:0] | | | | | | | |
| 20h | matk[15:8] | | | | | | | |
| satk matk | AGC Attack Rate These each represent a positive fractional value ranging linearly from 0.0 to slightly less than 1.0. It helps control the rate at which the AGC gain is reduced when the average Satellite or Mono Channel signal amplitude is above the corresponding AGC High Threshold (either Satellite or Mono Channel). Higher values mean the current AGC gain will be reduced more quickly, which will in turn lower the average AGC signal amplitude. The Satellite Channel AGC's operate independently, but receive the same settings. The Mono AGC is completely independent of the Satellite AGC's. Refer to the AGC Section for more information. | | | | | | | |

1Ch/1Dh AGCS_RELEASE - Satellite AGC Release Rate

21h/22h AGCM_RELEASE - Mono AGC Release Rate

| | Bit 15 | Bit 14 | Bit 13 | Bit 12 | Bit 11 | Bit 10 | Bit 9 | Bit 8 |
|----------------------------|---|--------|--------|--------|--------|--------|-------|-------|
| POR | 0 | 0 | 0 | 0 | 0 | 0 | 0 | 0 |
| Access | RW | RW | RW | RW | RW | RW | RW | RW |
| 1Ch | srel[7:0] | | | | | | | |
| 1Dh | srel[15:8] | | | | | | | |
| 21h | mrel[7:0] | | | | | | | |
| 22h | mrel[15:8] | | | | | | | |
| srel mrel | AGC Attack Rate These each represents a positive fractional value ranging linearly from 0.0 to slightly less than 1.0. It helps control the rate at which the AGC gain is increased when the average Satellite or Mono Channel signal amplitude is below the corresponding AGC Low Threshold (either Satellite or Mono Channel) AND above the corresponding AGC noise Threshold (either Satellite or Mono Channel). Higher values mean the current AGC gain will be increased more quickly, which will in turn raise the average AGC signal amplitude. The Satellite Channel AGC's operate independently, but receive the same settings. The Mono AGC is completely independent of the Satellite AGC's. Refer to the AGC Section for more information. | | | | | | | |

1Eh AGCS_ALPHA - Satellite AGC Alpha

26h AGCM_ALPHA - Mono AGC Alpha

| | Bit 7 | Bit 6 | Bit 5 | Bit 4 | Bit 3 | Bit 2 | Bit 1 | Bit 0 |
|--------------------------------|---|-------|-------|---------------|-------|-------|-------|-------|
| POR | 0 | 0 | 0 | 0 | 0 | 0 | 0 | 0 |
| Access | RO | RO | RO | RW | RW | RW | RW | RW |
| 1Eh | R | R | R | salpha | | | | |
| 26h | R | R | R | malpha | | | | |
| salpha malpha | AGC alpha (feed forward term) value These each represent a positive fractional value ranging 0.01 to 0.5 in 31 logarithmically spaced steps. This fractional value becomes the alpha term in a 1 st order IIR that measures the average AGC amplitude (each Satellite channel and the Mono Channel are independent of each other). Higher values mean the IIR will respond more quickly to average signal level changes. Lower values mean the IIR will respond more slowly to average signal level changes. salpha applies to each Satellite Channel. malpha applies only to the Mono Channel. | | | | | | | |

28h – 4Fh GEQ_Pm_Fn_GAIN - GEQ Profile Filter Gains

| GEQ Register Addresses | | Profile (m) | | | | | | | |
|------------------------|---|-------------|-----|-----|-----|-----|-----|-----|-----|
| | | 1 | 2 | 3 | 4 | 5 | 6 | 7 | 8 |
| Filter (n) | 1 | 28h | 2Dh | 32h | 37h | 3Ch | 41h | 46h | 4Bh |
| | 2 | 29h | 2Eh | 33h | 38h | 3Dh | 42h | 47h | 4Ch |
| | 3 | 2Ah | 2Fh | 34h | 39h | 3Eh | 43h | 48h | 4Dh |
| | 4 | 2Bh | 30h | 35h | 3Ah | 3Fh | 44h | 49h | 4Eh |
| | 5 | 2Ch | 31h | 36h | 3Bh | 40h | 45h | 4Ah | 4Fh |

| | Bit 7 | Bit 6 | Bit 5 | Bit 4 | Bit 3 | Bit 2 | Bit 1 | Bit 0 |
|----------------|---|-------|-------|----------------|-------|-------|-------|-------|
| POR | 0 | 0 | 0 | 0 | 0 | 0 | 0 | 0 |
| Access | RO | RO | RO | RW | RW | RW | RW | RW |
| Bits | R | R | R | geqgain | | | | |
| geqgain | Gain value; 0 to -31dB in 1dB steps 0 = 0dB 1 = -1dB ... 31 = -31 dB Each of the eight profiles above (designated by the PN columns) contains five filters (designated by the Filter rows), each of which can have a unique gain. This is a total of 40 filter gains in all. | | | | | | | |

50h DYB_THR_HI - Dynamic Bass High Threshold
54h DYT_THR_HI - Dynamic Treble High Threshold

| | Bit 7 | Bit 6 | Bit 5 | Bit 4 | Bit 3 | Bit 2 | Bit 1 | Bit 0 |
|--|--|-------|-------------------|-------|-------|-------|-------|-------|
| POR | 0 | 0 | 0 | 1 | 0 | 1 | 0 | 0 |
| Access | RO | RO | RW | RW | RW | RW | RW | RW |
| 50h | R | R | dyb_thr_hi | | | | | |
| 54h | R | R | dyt_thr_hi | | | | | |
| dyb_thr_hi dyt_thr_hi | Dynamic Bass and Dynamic Treble High Thresholds For Dynamic Bass (dyb_thr_hi), this represents an average amplitude level measured in dB down from Digital Full Scale (dBFS). When the low-passed average amplitude of the incoming signal is higher than this threshold, no gain is applied to the signal. When the low-passed average amplitude of the incoming signal is lower than this threshold, a gain is applied to the low frequency component. Exactly how much gain is applied depends on other parameters. 0 = 0 dB 1 = -1 dB etc. For example, if dyb_thr_hi = 13 decimal, the High Threshold is = -13 dBFS For Dynamic Treble (dyt_thr_hi), the operation is exactly the same, except the amplitude being measured, and the gain applied to it, is the high-pass filtered amplitude content, not the low-pass content. | | | | | | | |

51h DYB_THR_NO - Dynamic Bass Noise Threshold

55h DYT_THR_NO - Dynamic Treble Noise Threshold

| | Bit 7 | Bit 6 | Bit 5 | Bit 4 | Bit 3 | Bit 2 | Bit 1 | Bit 0 |
|--|--|-------|-------------------|-------|-------|-------|-------|-------|
| POR | 0 | 0 | 0 | 1 | 1 | 1 | 0 | 0 |
| Access | RO | RO | RW | RW | RW | RW | RW | RW |
| 51h | R | R | dyb_thr_no | | | | | |
| 55h | R | R | dvt_thr_no | | | | | |
| dyb_thr_no dvt_thr_no | <p>Dynamic Bass and Dynamic Treble Noise Threshold</p> <p>For Dynamic Bass (dyb_thr_no), this represents an average amplitude level measured in dB down from Digital Full Scale (dBFS) according to the following equation: Noise Threshold in dBFS = $-(\text{dyb_thr_no} + 32)$</p> <p>For example, when dyb_thr_no = 19 decimal, the Noise Threshold is $-(19+32) = -51$ dBFS</p> <p>The output of the 1st Exp. Averager in the Dynamic Bass Block is compared against this value. When the output is lower than dyb_thr_no, the 2nd Exp. Averaging IIR is not updated. When the output is higher than dyb_thr_no, the 2nd Exp. Averaging IIR is updated. The intent is that when the input consists of noise or very low level signals (such as during quiet times in music), the Dynamic Bass block won't continue updating itself, potentially adding significant gain to the Low Passed portion of the signal.</p> <p>For Dynamic Treble (dvt_thr_no), the operation is exactly the same, except the amplitude being measured, and the gain applied to it, is the high-pass filtered amplitude content, not the low-pass content.</p> | | | | | | | |

52h DYB_MAX_GAIN - Dynamic Bass Maximum Gain

56h DYT_MAX_GAIN - Dynamic Treble Maximum Gain

| | Bit 7 | Bit 6 | Bit 5 | Bit 4 | Bit 3 | Bit 2 | Bit 1 | Bit 0 |
|--|--|-------|-------|-------|--------------------|-------|-------|-------|
| POR | 0 | 0 | 0 | 0 | 1 | 1 | 0 | 0 |
| Access | RO | RO | RO | RO | RW | RW | RW | RW |
| 52h | R | R | R | R | dyb_maxgain | | | |
| 56h | R | R | R | R | dvt_maxgain | | | |
| dyb_maxgain dvt_maxgain | <p>Dynamic Bass and Dynamic Treble Maximum Gain</p> <p>For Dynamic Bass (dyb_max_gain), this represents the maximum gain that will be applied by the Dynamic Bass Block to the low pass filtered portion of the signal.</p> <p>For example, when dyb_maxgain = 9 decimal, the maximum gain to be applied is 9dB.</p> <p>For Dynamic Treble (dvt_maxgain), the operation is exactly the same, except the maximum gain limit is applied to high-pass filtered content, not low-pass filtered content.</p> | | | | | | | |

54h DYB_TRACK - Dynamic Bass Tracking Rate

57h DYT_TRACK - Dynamic Treble Tracking Rate

| | Bit 7 | Bit 6 | Bit 5 | Bit 4 | Bit 3 | Bit 2 | Bit 1 | Bit 0 |
|----------------------------------|--|-------|-------|-------|-------|-------|----------------|-------|
| POR | 0 | 0 | 0 | 0 | 0 | 0 | 1 | 1 |
| Access | RO | RO | RO | RO | RO | RO | RW | RW |
| 54h | R | R | R | R | R | R | dyb_trk | |
| 54h | R | R | R | R | R | R | dym_trk | |
| dyb_trk dym_trk | <p>Dynamic Bass and Dynamic Treble Tracking Rates</p> <p>For Dynamic Bass (dyb_trk), this represents the rate at which the gain applied to the Low Pass filtered signal will be increased as the average signal level drops below the Dynamic Bass High Threshold level.</p> <p>00 = For every dB drop, 1.00 dB of gain will be applied to the low-pass filtered signal content. 01 = For every dB drop, 0.75 dB of gain will be applied to the low-pass filtered signal content. 10 = For every dB drop, 0.50 dB of gain will be applied to the low-pass filtered signal content. 11 = For every dB drop, 0.25 dB of gain will be applied to the low-pass filtered signal content.</p> <p>For Dynamic Treble (dym_trk), the operation is exactly the same, except the tracking rate is applied to high-pass filtered content, not low-pass filtered content.</p> | | | | | | | |

58h SPI_TO_I2C - SPI to I2C Status

| | Bit 7 | Bit 6 | Bit 5 | Bit 4 | Bit 3 | Bit 2 | Bit 1 | Bit 0 |
|----------------|--|-------|-------|---------------|----------------|--------------|---------------|--------------|
| POR | 0 | 0 | 0 | 1 | 0 | 0 | 0 | 0 |
| Access | RO | RO | RO | RW | RO | RO | RO | RO |
| Bits | R | R | R | eesize | rdvalid | pdone | tabort | wdone |
| wdone | <p>SPI to I2C Write Done Flag</p> <p>This bit goes low when a SPI to I2C write is initiated by an external SPI master. It returns high when the write is complete on the I2C bus. It works with the tabort flag below. The two of them will never be high together.</p> <p>0 = The SPI to I2C write is pending on the I2C bus 1 = The SPI to I2C write completed successfully.</p> | | | | | | | |
| tabort | <p>SPI to I2C Target Abort Flag</p> <p>This bit goes low when a SPI to I2C write or read is initiated by an external SPI master. It returns high if the I2C operation ends in a Target Abort. It works with the wdone flag above and the rdvalid flag below. tabort and wdone will never be high together.</p> <p>0 = The SPI to I2C write is pending on the I2C bus 1 = The SPI to I2C write completed successfully.</p> | | | | | | | |
| pdone | <p>EEPROM Page Done Flag</p> <p>This bit is set whenever a write is done to the last byte in a page, and the whole page must then be written in the EEPROM. This is only for status. An external SPI master does not need to react differently when this bit is set vs. when it is clear.</p> <p>0 = The last byte written was not at the end of a page in the EEPROM 1 = The last byte written to the EEPROM was at the end of a page.</p> | | | | | | | |
| rdvalid | <p>Read Data Valid Flag</p> <p>This bit indicates when valid read data is available after a command is sent to perform a SPI to I2C read. It goes low when the SPI to I2C command is received and stays low until valid data has been received.</p> <p>0 = Valid Read Data is not yet available 1 = Valid Read Data is available and can be read at I2C_RDATA register.</p> | | | | | | | |
| eesize | <p>eesize indicates which kind of EEPROM will be accessed by subsequent SIB to I2C EEPROM accesses:</p> <p>0 = 8 bit EEPROM (no longer supported) 1 = 16 bit EEPROM</p> | | | | | | | |

59h I2C_RDATA - I2C Read Data

| | Bit 7 | Bit 6 | Bit 5 | Bit 4 | Bit 3 | Bit 2 | Bit 1 | Bit 0 |
|------------------|---|-------|-------|-------|-------|-------|-------|-------|
| POR | 0 | 0 | 0 | 0 | 0 | 0 | 0 | 0 |
| Access | RO | RO | RO | RO | RO | RO | RO | RO |
| Bits | i2c_rdata | | | | | | | |
| i2c_rdata | i2c_rdata is the data returned from the I2C during a SPI to I2C read command. It is valid after the rdvalid bit has been set in the SPI_TO_I2C register. | | | | | | | |

5Ah BOOT_STATUS - Boot Status

| | Bit 7 | Bit 6 | Bit 5 | Bit 4 | Bit 3 | Bit 2 | Bit 1 | Bit 0 |
|----------------|---|-------|--------------|------------|---------------|--------------|----------------|---------------|
| POR | 0 | 0 | 0 | 0 | 0 | 0 | 0 | 0 |
| Access | RO | RO | RO | RO | RO | RO | RO | RO |
| Bits | R | R | mdone | dnf | chksum | signv | baabort | bootok |
| bootok | Boot OK Flag Indicates if the Boot Sequence completed successfully or not. This means that either there was no EEPROM found or that there was an EEPROM found and was booted from successfully. 0 = Boot Failed 1 = Boot OK | | | | | | | |
| baabort | Boot Target Abort Flat Indicates if a target abort occurred during the boot sequence. This would occur if no 8-bit device was found, but a 16-bit device was found, since when the 8-bit device access was attempted, a target abort would occur. 0 = No Target abort occurred 1 = A Target abort occurred sometime during the boot process. | | | | | | | |
| signv | Signature Invalid Flag Indicates if an invalid signature was found or not. An invalid signature is when the first three bytes of the EEPROM header are not ascii 'Q', 'F', and 'T' respectively. 0 = Signature Valid (or no EEPROM found) 1 = Signature invalid | | | | | | | |
| chksum | CHKSUM Error Flag Indicates if a checksum error was found or not. An checksum error is when the checksum of the first 16 bytes of the header doesn't sum to 0x00 (upper bits ignored) 0 = Valid Checksum found or no EEPROM found) 1 = Checksum invalid | | | | | | | |
| dnf | Device Not Found Flag Indicates if neither an 8-bit nor a 16-bit EEPROM was found at the address determined by the SADx pins. 0 = An 8-bit or 16-bit EEPROM was found 1 = Device not found | | | | | | | |
| mdone | Boot Master Done Flag Indicates if the I2C Master is done with the boot sequence or not. Once this bit is set, the other bits in this register may be examined to determine how successful the boot sequence was. 0 = Master is not yet done 1 = Master done | | | | | | | |

5Bh PRO_VOL_HADDR - Profile Volume High Address

| | Bit 7 | Bit 6 | Bit 5 | Bit 4 | Bit 3 | Bit 2 | Bit 1 | Bit 0 |
|----------------|--|-------|-------|-------|-------|-------|-------|-------|
| POR | 0 | 0 | 0 | 0 | 0 | 0 | 0 | 0 |
| Access | RW | RW | RW | RW | RW | RW | RW | RW |
| Bits | pvhaddr | | | | | | | |
| pvhaddr | Profile / Volume EEPROM Address High Byte When the VUP, VDN, or PROF pins cause the selected volume or profile to change, the updated profile and volume values are written to an EEPROM at the address set by pvhaddr prepended to pvladdr . | | | | | | | |

5Ch PRO_VOL_LADDR - Profile Volume Low Address

| | Bit 7 | Bit 6 | Bit 5 | Bit 4 | Bit 3 | Bit 2 | Bit 1 | Bit 0 |
|----------------|---|-------|-------|-------|-------|-------|-------|-------|
| POR | 0 | 0 | 0 | 0 | 0 | 0 | 0 | 0 |
| Access | RW | RW | RW | RW | RW | RW | RW | RW |
| Bits | pvladdr | | | | | | | |
| pvladdr | Profile / Volume EEPROM Address Low Byte When the VUP, VDN, or PROF pins cause the selected volume or profile to change, the updated profile and volume values are written to an EEPROM at the address set by pvhaddr prepended to pvladdr . | | | | | | | |

5Dh PRO_CTRL – Master Profile Control

| | Bit 7 | Bit 6 | Bit 5 | Bit 4 | Bit 3 | Bit 2 | Bit 1 | Bit 0 |
|----------------|--|-------|----------------|-------|-------|----------------|-------|-------|
| POR | 0 | 0 | 1 | 1 | 1 | 0 | 0 | 0 |
| Access | RW | RW | RW | RW | RW | RW | RW | RW |
| Bits | R | R | maxprof | | | curprof | | |
| curprof | curprof is the currently selected profile, of which there are eight, indexed as 0 to 7. This value can be modified by the PROF pin or by an I2C or SPI master writing into the register. If this register is modified due to the PROF pin, and a valid EEPROM exists in the I2C address space, the new register value will be written to the EEPROM at the location indicated by the PRO_VOL_HADDR and PRO_VOL_LADDR registers. | | | | | | | |
| maxprof | maxprof is the highest profile that will be selected when using the PROF pin to cycle through the profiles. When using the PROF pin, no I2C or SPI master should program maxprof to be less than curprof . This register is not referenced if the PROF pin is not used. | | | | | | | |

5Eh CUR_VOL - Master Volume Control

| | Bit 7 | Bit 6 | Bit 5 | Bit 4 | Bit 3 | Bit 2 | Bit 1 | Bit 0 |
|---------------|---|---------------|-------|-------|-------|-------|-------|-------|
| POR | 0 | 1 | 1 | 0 | 0 | 0 | 1 | 1 |
| Access | RW | RW | RW | RW | RW | RW | RW | RW |
| Bits | R | curvol | | | | | | |
| curvol | <p>curvol is the current index into the Volume Table. This value can be modified by the VUP/VDN pins or by an I2C or SPI master writing into the register. If this register is modified due to VUP or VDN, and a valid EEPROM exists in the I2C address space, the new value will be written to the EEPROM at the location indicated by the PRO_VOL_HADDR and PRO_VOL_LADDR registers. Valid values are 0 decimal to 99 decimal. An external master writing values above 99 decimal will result in undefined behavior.</p> | | | | | | | |

5Fh MAX_VOL - Maximum Master Volume

| | Bit 7 | Bit 6 | Bit 5 | Bit 4 | Bit 3 | Bit 2 | Bit 1 | Bit 0 |
|---------------|--|---------------|-------|-------|-------|-------|-------|-------|
| POR | 0 | 1 | 1 | 0 | 0 | 0 | 1 | 1 |
| Access | RO | RW | RW | RW | RW | RW | RW | RW |
| Bits | R | maxvol | | | | | | |
| maxvol | <p>maxvol is the highest index that will be selected when traversing the Volume Table using the VUP and VDN pins. Valid values are 0 decimal to 99 decimal. Assigning this register a value above 99 decimal and then using the VUP or VDN pins will result in undefined behavior. When using the VUP/VDN pins, no I2C or SPI master should program maxvol to be less than curvol. This register is not referenced if the Current Master Volume register is updated solely by an I2C or SPI master.</p> | | | | | | | |

60h VSLEW - Volume Slew Rate

| | Bit 7 | Bit 6 | Bit 5 | Bit 4 | Bit 3 | Bit 2 | Bit 1 | Bit 0 |
|-------------|--|-------|-------|-------|-------------|-------|-------|-------|
| POR | 0 | 0 | 0 | 0 | 1 | 1 | 1 | 1 |
| Access | RO | RO | RO | RO | RW | RW | RW | RW |
| Field Name | R | R | R | R | slew | | | |
| slew | <p>Slew Rate for Master Volume, GEQ, MUTE, and Amp Protection circuitry Whenever the volume changes due to an adjustment in the master volume, GEQ, MUTE or amplifier protection circuitry, the actual gain applied to the circuitry is a slewed gain. The slew rate is sample rate dependent. At 48 kHz the following table is true. Halving the sample rate will double the slew rate, etc.</p> <ul style="list-style-type: none"> 0 = 48 dB/ms 1 = 24 dB/ms 2 = 12 dB/ms 3 = 6 dB/ms 4 = 3 dB/ms 5 = 1.5 dB/ms 6 = 0.75 dB/ms 7 = 0.375 dB/ms 8 = 0.188 dB/ms 9 = 94 dB/sec 10 = 47 dB/sec 11 = 23 dB/sec 12, 13, 14 = N/A Do Not Use 15 = Instantaneous | | | | | | | |

62h BTNCTRL – Volume Pins (usually tied to Buttons) and Tone Control

| | Bit 7 | Bit 6 | Bit 5 | Bit 4 | Bit 3 | Bit 2 | Bit 1 | Bit 0 |
|---------------|---|-------|------------|---------------|-------------|------------|------------|-------------|
| POR | 0 | 0 | 0 | 0 | 0 | 0 | 0 | 0 |
| Access | RO | RO | RW | RW | RW | RW | RW | RW |
| Bits | R | R | ben | volsus | mute | vdn | vup | prof |
| prof | 0 = No tone is produced when the PROF pin is asserted low 1 = A tone is produced when the PROF pin is asserted low and BEN = 1 | | | | | | | |
| vup | Controls whether a tone is produced when the VDN pin is driven low. 0 = No tone is produced when the VUP pin is asserted low 1 = A tone is produced when <ul style="list-style-type: none"> a) the VUP pin is asserted low and b) ben = 1 and c) the CUR_VOL register is not equal to MAX_VOL | | | | | | | |
| vdn | Controls whether a tone is produced when the VDN pin is driven low. 0 = No tone is produced when the VDN pin is asserted low 1 = A tone is produced when <ul style="list-style-type: none"> a) the VDN pin is asserted low and b) ben = 1 and the CUR_VOL register is not equal to 0 | | | | | | | |
| mute | Controls whether a tone is produced when the MUTE pin is driven low. 0 = No tone is produced when the MUTE pin is asserted low 1 = A tone is produced when the MUTE pin is asserted low and ben = 1 Note: A tone may only partially be heard because the muting function may be attenuating the signal during the time the tone is being played. | | | | | | | |
| volsus | Controls whether a tone is repeatedly produced when the VUP or VDN pins are driven low and held. Holding either of these two pins low will cause the volume pointer to step repeated up or down the volume table. 0 = No tone is produced under the above conditions 1 = A brief tone is repeatedly produced when the VUP or VDN pins are driven low and held for more than two seconds, and ben = 1 | | | | | | | |
| ben | Enables the four volume related pins (VUP, VDN, MUTE, PROF) 0 = All pins disabled (asserting any of them low will have no effect) 1 = all pins enabled | | | | | | | |

63h AMP_DROP - Amplifier Protection

| | Bit 7 | Bit 6 | Bit 5 | Bit 4 | Bit 3 | Bit 2 | Bit 1 | Bit 0 |
|-----------------|--|-------|-------|-----------------|-------|-------|-------|-------|
| POR | 0 | 0 | 0 | 0 | 0 | 0 | 1 | 1 |
| Access | RO | RO | RO | RW | RW | RW | RW | RW |
| Bits | R | R | R | amp_drop | | | | |
| amp_drop | This represents how many dB the Master Gain will be reduced by when the AMP pin is asserted. Any amplitude change will be slewed according to the Profile Volume Slew amount, and thus be somewhat gradual. 0 = 0 dB drop 1 = 1 dB drop . . . The maximum drop is 31 dB. | | | | | | | |

64h TONE_GEN - Tone Control

| | Bit 7 | Bit 6 | Bit 5 | Bit 4 | Bit 3 | Bit 2 | Bit 1 | Bit 0 |
|----------------|---|-------|-------|-------|-------|-------|---------|---------|
| POR | 0 | 0 | 0 | 0 | 0 | 0 | 0 | 0 |
| Access | RO | RO | RO | RO | RO | RO | RW | RW |
| Bits | R | R | R | R | R | R | tone2en | tone1en |
| tone1en | Tone 1 Generation controlled by an external microprocessor 0 = Tone 1 Disabled 1 = Tone 1 Enabled | | | | | | | |
| tone2en | Tone 2 Generation controlled by an external microprocessor 0 = Tone 2 Disabled 1 = Tone 2 Enabled | | | | | | | |

87h – 95h IO_XXX - Input Pins Control

| | Bit 7 | Bit 6 | Bit 5 | Bit 4 | Bit 3 | Bit 2 | Bit 1 | Bit 0 |
|-----------------|---|-------|-------|-------|-------|-------|-------|--------|
| Access | RO | RO | RO | RO | RO | RW | RW | RW |
| Bits | R | R | R | R | R | pu_en | pd_en | smt_en |
| 89h, dSCK | 0 | 0 | 0 | 0 | 0 | 0 | 0 | 1 |
| 8Ah, dCS | 0 | 0 | 0 | 0 | 0 | 0 | 0 | 1 |
| 8Bh, dSDI | 0 | 0 | 0 | 0 | 0 | 0 | 0 | 1 |
| 8Ch, cCSn | 0 | 0 | 0 | 0 | 0 | 1 | 0 | 1 |
| 8Dh, cSCK | 0 | 0 | 0 | 0 | 0 | 0 | 1 | 1 |
| 8Eh, cSDI | 0 | 0 | 0 | 0 | 0 | 0 | 1 | 1 |
| 8Fh, cSAD1 | 0 | 0 | 0 | 0 | 0 | 0 | 1 | 0 |
| 90H, cSAD2 | 0 | 0 | 0 | 0 | 0 | 0 | 1 | 0 |
| 91h, VUP & VDN* | 0 | 0 | 0 | 0 | 0 | 1 | 0 | 1 |
| 93h, PROF | 0 | 0 | 0 | 0 | 0 | 1 | 0 | 1 |
| 94h, AMP | 0 | 0 | 0 | 0 | 0 | 0 | 1 | 1 |
| 95h, MUTE | 0 | 0 | 0 | 0 | 0 | 1 | 0 | 1 |
| pu_en | Enables the pull up resistor on the pin. 0 = No pull up resistor on input. 1 = 75K Ohm pull up resistor on input | | | | | | | |
| pd_en | Enables the pull down resistor on the pin. 0 = No pull down resistor on input. 1 = 75K Ohm pull down resistor on input. | | | | | | | |
| smt_en | Enables the Schmitt trigger input on the pin. 0 = Normal input. 1 = Schmitt trigger input. | | | | | | | |

* The config bits in address 0x91 control both the VUP and the VDN pins. The config bits in address 0x92 exist as in address 0x91, but do not perform any function.

96h – 97h IO_XXX – Bidirectional Pins Control

| | Bit 7 | Bit 6 | Bit 5 | Bit 4 | Bit 3 | Bit 2 | Bit 1 | Bit 0 |
|--------------|--|--------------|-------|-------|-----------|--------------|--------------|------------|
| Access | RO | RW | RW | RW | RW | RW | RW | RW |
| Bits | R | drive | | | sr | pu_en | pd_en | spr |
| 96h, cSCL | 0 | 1 | 0 | 0 | 0 | 1 | 0 | 0 |
| 97h, cSDA | 0 | 1 | 0 | 0 | 0 | 1 | 0 | 0 |
| drive | Determines the drive strength of the output driver. VDDIO 3.3V / 2.5 V / 1.8 V 0 = 2 mA / 1.1 mA / 0.7 mA 1 = 4 mA / 2.2 mA / 1.4 mA 2 = 6 mA / 3.3 mA / 2.1 mA 3 = 8 mA / 4.4 mA / 2.8 mA 4 = 10 mA / 5.5 mA / 3.5 mA (POR) 5 = 12 mA / 6.6 mA / 4.2 mA 6 = 14 mA / 7.7 mA / 4.9 mA 7 = 16 mA / 8.8 mA / 5.6 mA | | | | | | | |
| sr | Controls the Slew Rate of the output driver. 0 = Fast 1 = Slow | | | | | | | |
| pu_en | Enables the pull up resistor on the pin. 0 = No pull up resistor on input. 1 = 75K Ohm pull up resistor on input | | | | | | | |
| pd_en | Enables the pull down resistor on the pin. 0 = No pull down resistor on input. 1 = 75K Ohm pull down resistor on input. | | | | | | | |
| spr | These are spare unused bits. Schmitt triggering is always enabled on cSCL and cSDA. | | | | | | | |

96h – 97h IO_XXX – Output Pins Control

| | Bit 7 | Bit 6 | Bit 5 | Bit 4 | Bit 3 | Bit 2 | Bit 1 | Bit 0 |
|--------------|--|-------|-------|-------|--------------|-------|-------|-----------|
| Access | RO | RO | RO | RO | RW | RW | RW | RW |
| Bits | R | R | R | R | drive | | | sr |
| 98h, SDO | 0 | 0 | 0 | 0 | 1 | 0 | 0 | 0 |
| 99h, dSDO1 | 0 | 0 | 0 | 0 | 1 | 0 | 0 | 0 |
| 9Ah, dSDO2 | 0 | 0 | 0 | 0 | 1 | 0 | 0 | 0 |
| 9Bh, dSDO3 | 0 | 0 | 0 | 0 | 1 | 0 | 0 | 0 |
| drive | Determines the drive strength of the output driver. VDDIO 3.3V / 2.5 V / 1.8 V 0 = 2 mA / 1.1 mA / 0.7 mA 1 = 4 mA / 2.2 mA / 1.4 mA 2 = 6 mA / 3.3 mA / 2.1 mA 3 = 8 mA / 4.4 mA / 2.8 mA 4 = 10 mA / 5.5 mA / 3.5 mA (POR) 5 = 12 mA / 6.6 mA / 4.2 mA 6 = 14 mA / 7.7 mA / 4.9 mA 7 = 16 mA / 8.8 mA / 5.6 mA | | | | | | | |
| sr | Controls the Slew Rate of the output driver. 0 = Fast 1 = Slow | | | | | | | |

8 ELECTRICAL SPECIFICATION

8.1 Absolute Maximum Ratings

Stresses above those listed under Absolute Maximum Ratings can cause permanent device failure. Functionality at or above these limits is not implied. Exposure to absolute maximum ratings for extended periods may affect device reliability.

| Parameter | Min | Max | Units |
|--|------|------|-------|
| Storage Temperature | -40 | 150 | °C |
| Supply Voltage, V_{DD18} to GND | -0.3 | 2.16 | V |
| Supply Voltage, V_{DD33} with respect to GND | -0.3 | 4.0 | V |
| Digital Input Voltage with respect to GND | -0.3 | 4.0 | V |
| Digital Input Voltage with respect to V_{DD33} | | 0.7 | V |
| ESD Immunity (HBM, JESD22-A114-D Class 1C) | | 7.5 | KV |
| ESD Immunity (HBM, AEC-Q100-002D) | | 6.75 | KV |



This integrated circuit can be damaged by ESD. Quickfilter Technologies recommends that all integrated circuits be handled with appropriate precautions. Failure to observe proper handling and installation procedures can cause damage.

8.2 Recommended Operating Conditions

| Parameter | Symbol | Min | Typ | Max | Units |
|---------------------|------------|------|-----|------|-------|
| Supply Voltage 1.8 | V_{DD18} | 1.62 | 1.8 | 1.98 | V |
| Supply Voltage 3.3 | V_{DD33} | 3.0 | | 3.6 | V |
| Ambient Temperature | T_A | -40 | 25 | 85 | °C |

Note: Quickfilter guarantees the performance of this device over specified ranges by conducting electrical characterization over each range and by conducting a production test with single insertion coupled to periodic sampling.

8.3 Typical Performance Characteristics

Default Conditions: $T_A = 25\text{ C}$, $V_{DDCORE} = 1.8\text{ V}$,

IO Cell characteristics fall under one of three voltage levels appropriate to the V_{DD33} voltage:

3.3 Volt LVTTTL for $V_{DD33} = 3.3\text{ V} \pm 10\%$

2.5 Volt CMOS for $V_{DD33} = 2.5\text{ V} \pm 10\%$

1.8 Volt CMOS for $V_{DD33} = 1.8\text{ V} \pm 10\%$

The QF3DFX will operate with any V_{DD33} voltage between 3.63 V and 1.62 V, as long as appropriate input and output levels/loading are observed.

8.3.1 DC Electrical Characteristics

3.3V TTL - Conditions: $V_{DD33} = 3.3\text{ V} \pm 10\%$

| Symbol | Parameter (Condition) | Min | Typ | Max | Units | Note |
|----------|--|------|------|------|-------|------|
| V_{IL} | Low-level Input Voltage, $V_{DD33} = 2.97\text{ V}$ | -0.3 | | 0.8 | V | |
| V_{IH} | High-level Input Voltage, $V_{DD33} = 3.63\text{ V}$ | 2.0 | | 3.63 | V | |
| V_T | Switching Threshold (Non-Schmitt triggered) | | 1.6 | | V | |
| V_{T-} | Switching Threshold (Schmitt triggered – negative edge) | 0.8 | 1.25 | | V | |
| V_{T+} | Switching Threshold (Schmitt triggered – positive edge) | | 1.75 | 2.0 | V | |
| R_{PU} | Pull Up Resistance | 40 | 75 | 190 | KOhm | |
| R_{PD} | Pull Down Resistance | 40 | 75 | 190 | KOhm | |
| V_{OL} | Low-level Output Voltage, $V_{DD33} = 3.63\text{ V}$, $I_{OL} = 2\text{ mA} \sim 16\text{ mA}$ | | | 0.4 | V | 1 |
| V_{OH} | High-level Output Voltage, $V_{DD33} = 2.97\text{ V}$, $I_{OH} = -2\text{ mA} \sim -16\text{ mA}$ | 2.4 | | | V | 1 |

2.5V CMOS - Conditions: $V_{DD33} = 2.5\text{ V} \pm 10\%$

| Symbol | Parameter (Condition) | Min | Typ | Max | Units | Note |
|----------|---|-------------------|------|-------------------|-------|------|
| V_{IL} | Low-level Input Voltage ($V_{DD33} = 2.25\text{ V}$) | -0.3 | | $0.25 * V_{DD33}$ | V | |
| V_{IH} | High-level Input Voltage ($V_{DD33} = 2.75\text{ V}$) | $0.63 * V_{DD33}$ | | 2.75 | V | |
| V_T | Switching Threshold (Non-Schmitt triggered) | | 1.15 | | V | |
| V_{T-} | Switching Threshold (Schmitt triggered – negative edge) | $0.25 * V_{DD33}$ | 0.94 | | V | |
| V_{T+} | Switching Threshold (Schmitt triggered – positive edge) | | 1.4 | $0.63 * V_{DD33}$ | V | |
| R_{PU} | Pull Up Resistance | 45 | 110 | 290 | KOhm | |
| R_{PD} | Pull Down Resistance | 45 | 115 | 290 | KOhm | |
| V_{OL} | Low-level Output Voltage, $V_{DD33} = 3.63\text{ V}$, $I_{OL} = 1.1\text{ mA} \sim 8.8\text{ mA}$ | | | 0.4 | V | 1 |
| V_{OH} | High-level Output Voltage, $V_{DD33} = 2.97\text{ V}$, $I_{OH} = -1.1\text{ mA} \sim -8.8\text{ mA}$ | 1.85 | | | V | 1 |

1.8V CMOS - Conditions: $V_{DD33} = 1.8V \pm 10\%$

| Symbol | Parameter (Condition) | Min | Typ | Max | Units | Note |
|----------|---|-------------------|------|------------------|-------|------|
| V_{IL} | Low-level Input Voltage ($V_{DD33} = 1.62V$) | -0.3 | | $0.3 * V_{DD33}$ | V | |
| V_{IH} | High-level Input Voltage ($V_{DD33} = 1.98V$) | $0.7 * V_{DD33}$ | | 1.98 | V | |
| V_T | Switching Threshold (Non-Schmitt triggered) | | 0.85 | | V | |
| V_{T-} | Switching Threshold (Schmitt triggered – negative edge) | $0.3 * V_{DD33}$ | 0.65 | | V | |
| V_{T+} | Switching Threshold (Schmitt triggered – positive edge) | | 1.08 | $0.7 * V_{DD33}$ | V | |
| R_{PU} | Pull Up Resistance | 80 | 200 | 510 | KOhm | |
| R_{PD} | Pull Down Resistance | 80 | 210 | 510 | KOhm | |
| V_{OL} | Low-level Output Voltage, $V_{DD33} = 1.98V$, $I_{OL} = 0.7mA \sim 5.6mA$ | | | 0.4 | V | 1 |
| V_{OH} | High-level Output Voltage, $V_{DD33} = 1.62V$, $I_{OH} = -0.7mA \sim -5.6mA$ | $0.75 * V_{DD33}$ | | | V | 1 |

Current, Leakage, and Capacitance - Conditions: $V_{DD33} = 3.3V$

| Symbol | Parameter (Condition) | Min | Typ | Max | Units | Note |
|------------------|---|-----|-------|-----|-------|------|
| I_{DDD18} | 1.8V Supply Operating Current ($f_s = 48\text{ kHz}$) | | 11.6 | | mA | |
| I_{DDS18} | 1.8V Supply Operating Current (Standby) | | <10 | | uA | |
| I_{DDD33} | 3.3V Supply Operating Current ($f_s = 48\text{ kHz}$) | | 200 | | uA | 2 |
| I_{DDS33} | 3.3V Supply Operating Current (Standby) | | <10 | | uA | 3 |
| I_{IH}, I_{IL} | Input Leakage Current ($V_{in} = V_{DD33}$ or $0V$) | -10 | +/- 1 | 10 | uA | |
| I_{OZ} | Tristate Output Leakage Current ($V_{in} = V_{DD33}$ or $0V$) | -10 | +/- 1 | 10 | uA | |
| C_{IN} | Input Capacitance | | | 10 | pF | |
| C_O | Output Capacitance | | | 10 | pF | |
| C_{load} | Load Capacitance | | | 7 | pF | |

Note 1: Each output has eight programmable drive strength values. The appropriate current load should be used for the corresponding drive strength programmed. For example, with $V_{DD33} = 3.3V$, an output buffer programmed to use the weakest drive strength should apply a 2mA source or sink current when measuring V_{OL} or V_{OL-} . If the next strongest drive strength is programmed, a 4mA source or sink current should be applied. Lower drive strengths result when using lower V_{DD33} values.

Note 2: SPI and SIB inactive. All pins with pull-ups / pulldowns enabled are not being actively driven by another device.

Note 3: Audio Data Bus, SPI and SIB all inactive. All pins with pull-ups / pulldowns enabled are not being actively driven by another device.

8.4 AC Electrical Characteristics

8.4.1 SPI Configuration Timing Requirements

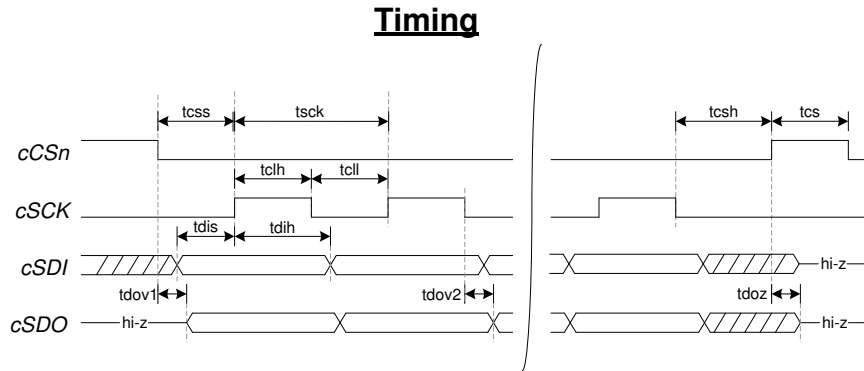

| Symbol | Parameter (SPI Input) | Min | Max | Units | Note |
|--------------|--|-----|-----|-------|------|
| <i>tsck</i> | SPI Port Clock Period | 40 | | nS | |
| <i>fsck</i> | SPI Port Clock Frequency (1/ <i>tsck</i>) | | 25 | MHz | |
| <i>tcll</i> | <i>cSCK</i> low time | 10 | | nS | |
| <i>tclh</i> | <i>cSCK</i> high time | 10 | | nS | |
| <i>tcss</i> | <i>cCSn</i> falling to <i>cSCK</i> rising time | 7 | | nS | |
| <i>tcsh</i> | <i>cSCK</i> falling to <i>cCSn</i> rising time | 10 | | nS | |
| <i>tcs</i> | <i>cCSn</i> high time | 50 | | nS | |
| <i>tdis</i> | <i>cSDI</i> setup time | 7 | | nS | |
| <i>tdih</i> | <i>cSDI</i> hold time | 10 | | nS | |
| <i>tdov1</i> | <i>cCSn</i> falling to <i>cSDO</i> valid time | | 10 | nS | |
| <i>tdov2</i> | <i>cSCK</i> falling to <i>cSDO</i> valid time | | 10 | nS | |
| <i>tdoz</i> | <i>cCSn</i> rising to <i>SDO</i> high-Z time | | 10 | nS | |

Table 8-1 - SPI Interface Bus Timing

8.4.2 SIB Timing Requirements

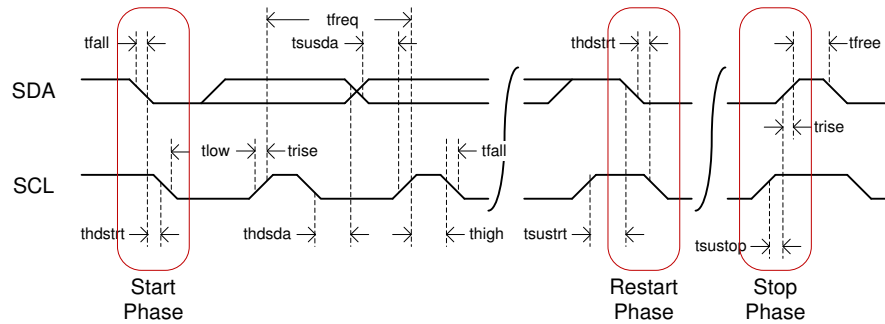
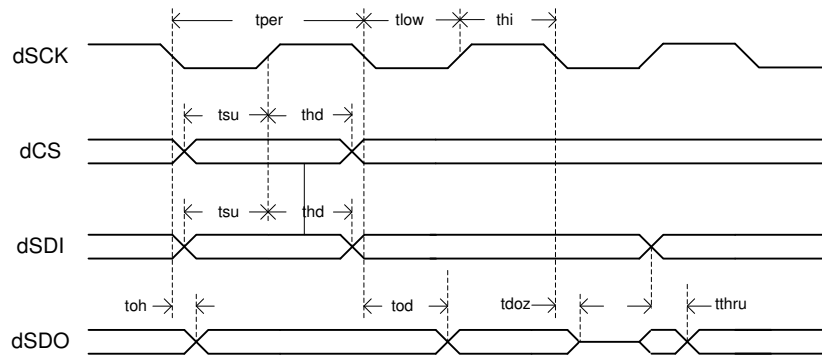

Figure 8-1 - Serial Interface Bus Timing Diagram

| Symbol | Parameter (SPI Input) | Min | Max | Units | Note |
|---------|--|-----|-----|-------|------|
| tfreq | SCLK Frequency | | 400 | kHz | |
| thdst | Start Phase Hold Time SCL Falling after SDA Falling | 160 | | ns | |
| tsustr | Restart Phase Setup Time SCL Rising to SDA Falling | 160 | | ns | |
| tsustop | Stop Phase Setup Time SCL Rising to SDA Rising | 160 | | ns | |
| tfall | SDA / SCL Fall Time | 20 | 160 | ns | |
| trise | SDA / SCL Rise Time | 20 | 160 | ns | |
| tlow | SCL Low Time | 320 | | ns | |
| thigh | SCL High Time | 120 | | ns | |
| tsusda | Data Phase Setup Time SDA to SCL Rising | 10 | | ns | |
| thdsda | Data Phase Hold Time Data Valid after SCL Falling | 160 | | ns | |
| tfree | SDA High Time during Bus Idle | 1.3 | | us | |

Table 8-2 - Serial Interface Bus Timing

8.4.3 Audio Data Path Timing Requirements



Note: dSCK polarity is inverted if dsck_pol=0

Figure 8-2 - Audio Data Path Timing Diagram 1

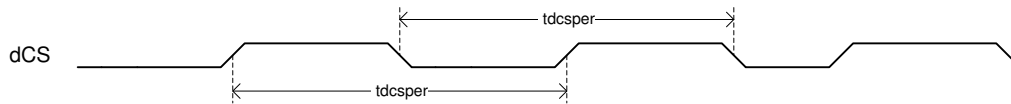

Figure 8-3 - Audio Data Path Timing Diagram 2

| Symbol | Parameter(SPI Output) | Min | Max | Units | Note |
|----------|--|-----|-----|-------|------|
| tfreq | dSCK Frequency | | 25 | MHz | |
| tper | dSCK Period | 40 | | ns | |
| tsu | dCS / dSDI Setup to dSCK Rising | 3 | | ns | |
| tdh | dCS / dSDI Hold from dSCK Rising | 5 | | ns | |
| toh | dSDO Output Hold from dSCK Falling | 0 | | ns | |
| tod | dSDOn Delay from dSCK Falling (normal mode) | | 6 | ns | |
| tdoz | dSDOn Tristate from dSCK Falling | | 6 | ns | |
| tthru | dSDOn Delay from dSDI (passthru mode) | 8 | | ns | |
| tdcspcr | dCS Rising to Rising or Falling to Falling | 20 | | us | |
| tdcsfreq | dCS Frequency (1/tdcspcr) | | 50 | kHz | |

Table 8-3 - Audio Data Path Timing

8.4.4 Miscellaneous Timing Requirements

| Symbol | Parameter(SPI Output) | Min | Max | Units | Note |
|--------|--------------------------------------|-----|-----|-------|------|
| trstl | RSTn low after VDD33 and VDD18 Valid | 50 | | ns | |

Table 8-4 – Miscellaneous Timing Requirements

9 CONNECTION DIAGRAMS

9.1 Electrical Connections

The diagram below illustrates recommended components and their values in a typical system.

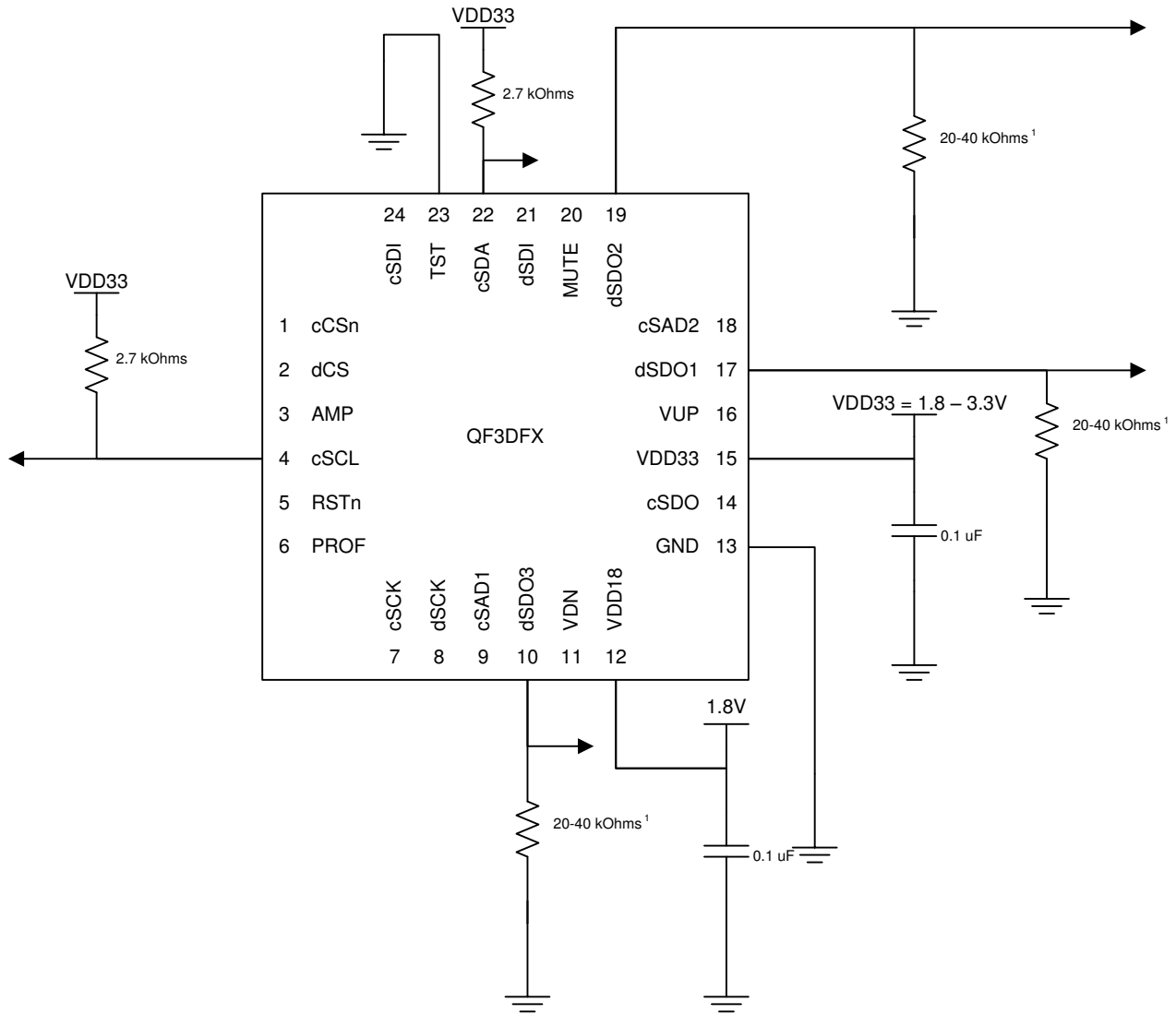

1. A weak pulldown resistor is recommended on each dSDOn line as the dSDOn pins tristate when `filt_en` and `din_pt` in the CONTROL register are both low.

Figure 9-1 Recommended Electrical Connection

9.2 Example Systems

9.2.1 SPI-Based Microcontroller

The diagram below illustrates a system with separate ADC, DAC, and Micro (used to boot and program from).

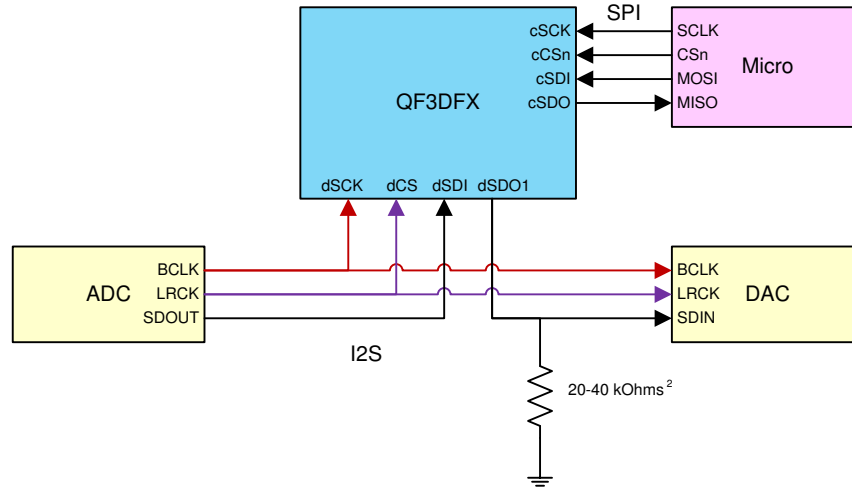

Note: The QF3DFX is always an I2S Slave, but any other device may control the Bit Clock (BCLK) and Word Select (LRCK) lines.

Figure 9-2 QF3DFX With SPI-Based Microcontroller

9.2.2 SIB-Based Microcontroller

The diagram below illustrates a system with separate ADC, DAC, and SIB-Based (2-Wire Interface) Micro. The micro provides all boot code and programming of the QF3DFX.

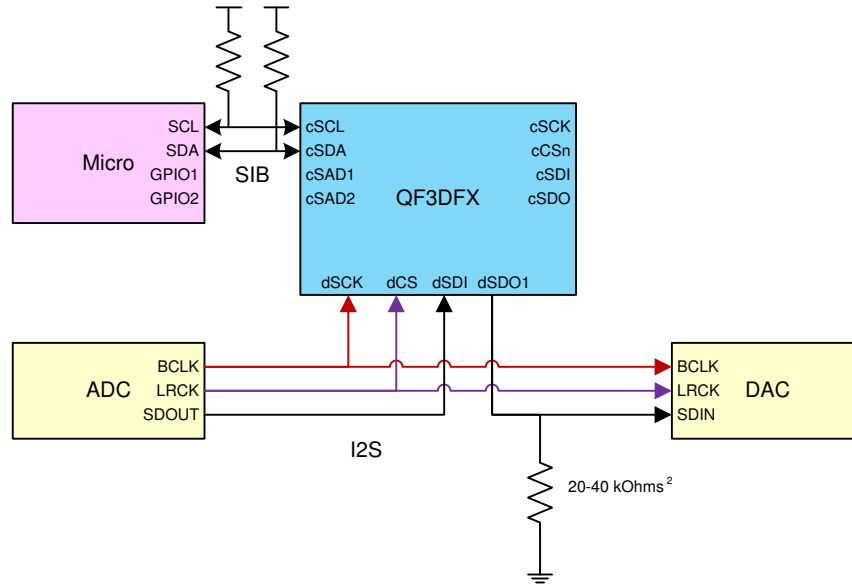

Note: The QF3DFX is always an I2S Slave, but any other device may control the Bit Clock (BCLK) and Word Select (LRCK) lines.

Figure 9-3 QF3DFX With SIB-Based Microcontroller

9.2.3 SPI-Based Microcontroller with QF3DFX Boot EEPROM

The diagram below illustrates a system with separate ADC, DAC, and SPI-based Micro. The QF3DFX gets its initial boot code from an SIB-based EEPROM, but most subsequent programming comes from the SPI-based Micro.

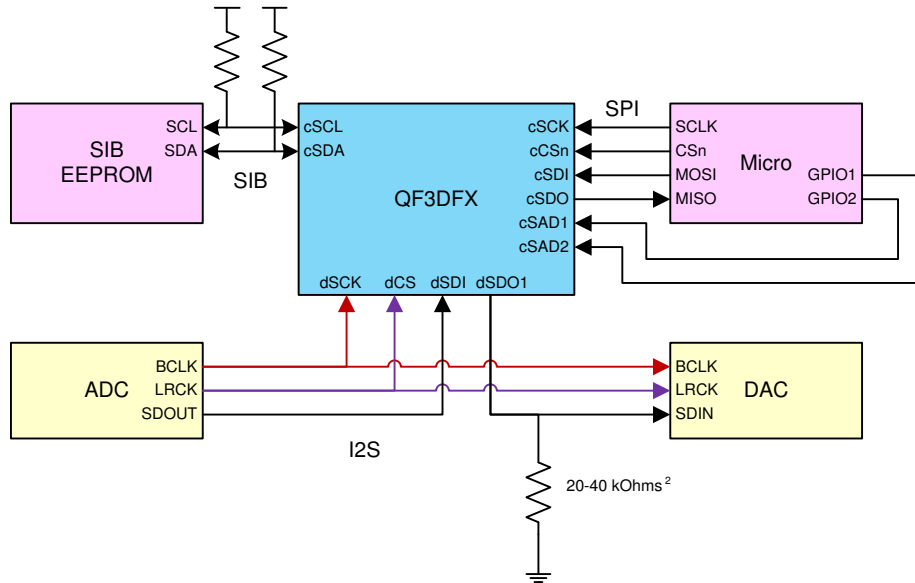

Note: The QF3DFX is always an I2S Slave, but any other device may control the Bit Clock (BCLK) and Word Select (LRCK) lines.

Figure 9-4 QF3DFX With SPI-Based Microcontroller and Boot EEPROM

10 PACKAGING INFORMATION

10.1 Package Assembly

The QF3DFX is offered in a “green” package (RoHS & no Sb/Br), assembled with enhanced environmentally compatible Pb-free and halide-free materials. The leads possess a matte-tin plating which is compatible with conventional board assembly processes or newer lead-free board assembly processes. The peak soldering temperature should not exceed 260°C during printed circuit board assembly.

4 x 4 x 0.9mm, VQFN 24, 0.8 mm Pull Back Lead (JEDEC)

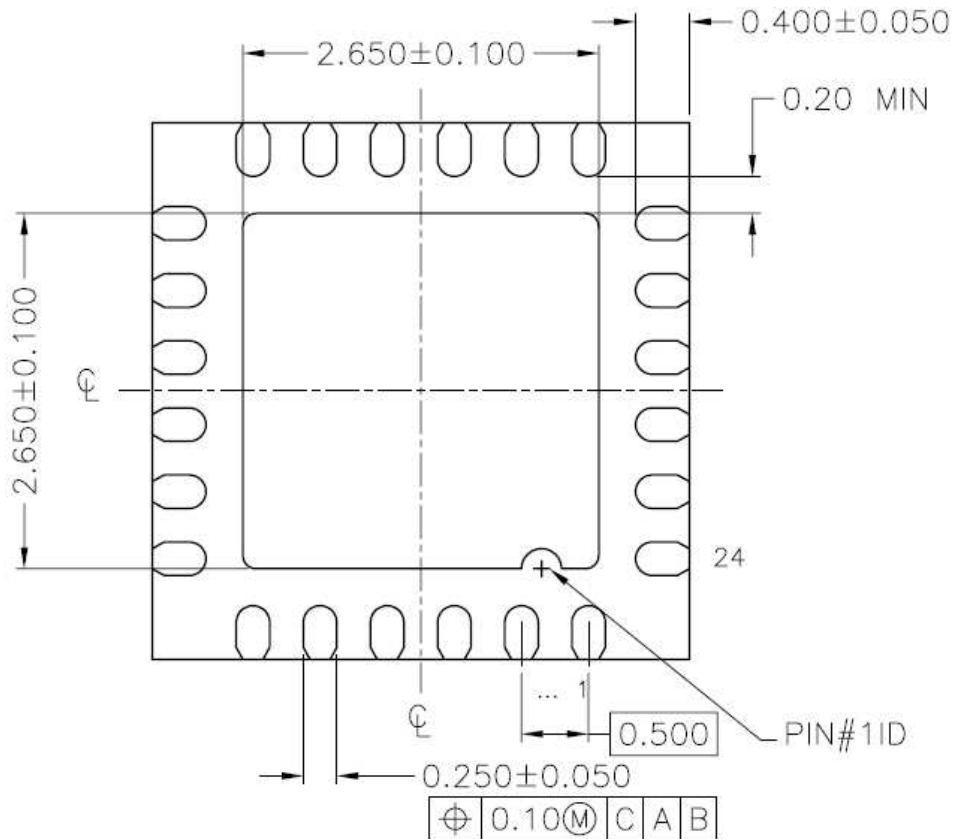

Figure 10-1- VQFN 24, Bottom View

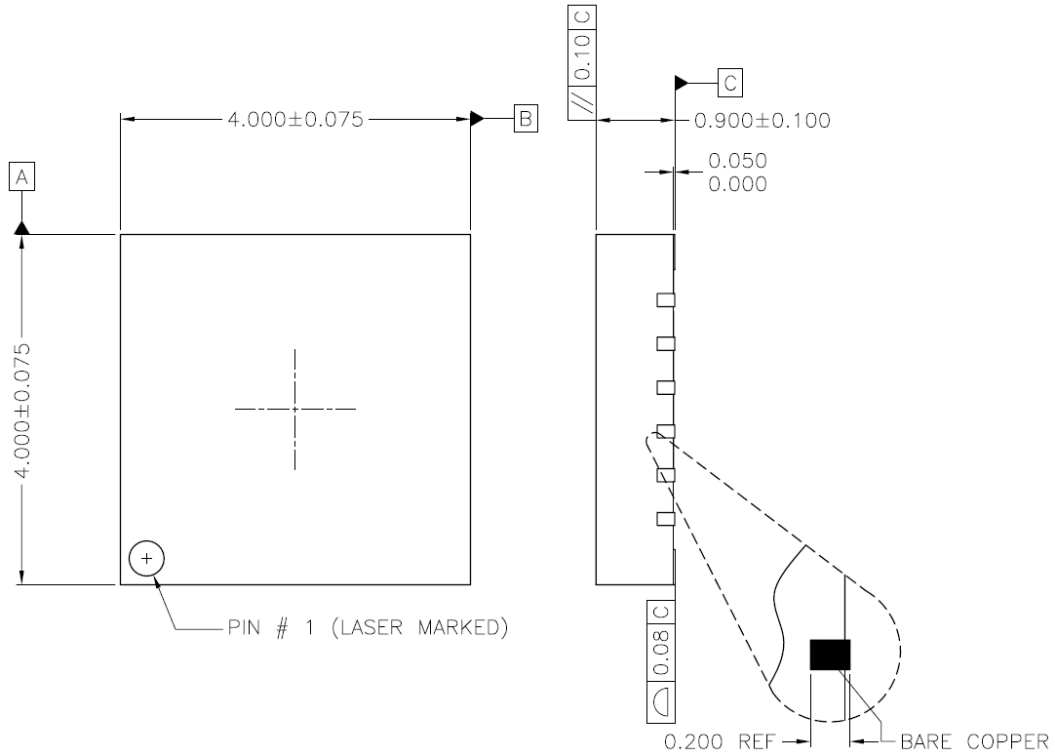

Figure 10-2 - VQFN 24, Top / Side View

Notes:

1. Dimensions are in millimeters.
2. Interpret dimensions and tolerance per ASME Y14.5M-1994

11 ORDERING INFORMATION

| Device | Package |
|-----------------|--|
| QF3DFX0QN02400T | 24-Pin QFN - Tape & Reel (Reel qty 1000) |
| QF3DFX-DK | Evaluation Platform |

The contents of this document are provided in connection with Quickfilter Technologies, LLC. products. Quickfilter makes no representations or warranties with respect to the accuracy or completeness of the contents of this publication and reserves the right to make changes to specifications and product descriptions at any time without notice. No license, whether express, implied, arising by estoppel or otherwise, to any intellectual property rights is granted by this publication. Except as set forth in Quickfilter's Standard Terms and Conditions of Sale, Quickfilter assumes no liability whatsoever, and disclaims any express or implied warranty, relating to its products including, but not limited to, the implied warranty of merchantability, fitness for a particular purpose, or infringement of any intellectual property right. Quickfilter's products are not designed, intended, authorized or warranted for use as components in systems intended for surgical implant into the body, or in other applications intended to support or sustain life, or in any other application in which the failure of Quickfilter's product could create a situation where personal injury, death, or severe property or environmental damage may occur. Quickfilter reserves the right to discontinue or make changes to its products at any time without notice.

© 2011 Quickfilter Technologies, Inc.
All rights reserved.

1024 S. Greenville Ave
Suite 130
Allen, TX 75002-3344

Telephone: (214) 547-0460
Fax: (214) 547-0481

For inquiries, please contact Quickfilter at the above address,

Or visit our website:
<http://www.quickfiltertech.com>

Quickfilter, the Quickfilter logo and "Programmable Signal Converter", and combinations thereof, are trademarks of Quickfilter Technologies, Inc. Other product names used in this publication are for identification purposes only and may be trademarks of their respective companies.