

Nano SocketLAN™

# Nano SocketLAN™

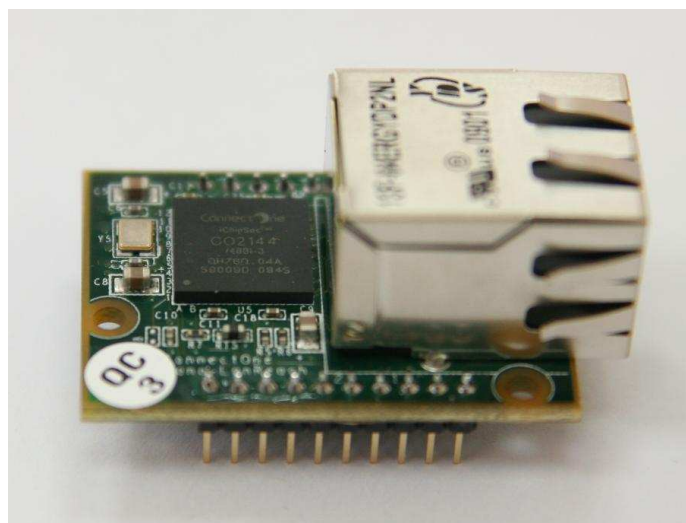

## Data Sheet

Ver. 1.20

**Connect**one™

**International:**

Connect One Ltd.

20 Atir Yeda Street

Kfar Saba 44643, Israel

Phone: +972-9-766-0456

Fax: +972-9-766-0461

Email: [sales@connectone.com](mailto:sales@connectone.com)

**USA:**

560 S. Winchester Blvd.

Suite 500

San Jose, CA 95128

Tel: (408) 572-5675

Fax: (408) 572-5601

Information provided by Connect One Ltd. is believed to be accurate and reliable. However, Connect One assumes no responsibility for its use, nor any infringement of patents or other rights of third parties, which may result from its use. No license is granted by implication or otherwise under any patent rights of Connect One other than for circuitry embodied in Connect One's products. Connect One reserves the right to change circuitry at any time without notice. This document is subject to change without notice.

The software described in this document is furnished under a license agreement and may be used or copied only in accordance with the terms of such a license agreement. It is forbidden by law to copy the software on any medium except as specifically allowed in the license agreement. No part of this document may be reproduced or transmitted in any form or by any means, electronic or mechanical, including but not limited to photocopying, recording, transmitting via fax and/or modem devices, scanning, and/or information storage and retrieval systems for any purpose without the express written consent of Connect One.

iChip, Nano SocketLAN, IP Communication Controller, SerialNET, AT+i and Connect One are trademarks of Connect One Ltd.

Copyright © 2009, Connect One Ltd. All rights reserved.

# Revision History

## 11-4200-05

Version	Date	Description
1.00	July 2009	Initial preliminary version
1.05	July 2009	Miscellaneous corrections
1.10	July 2009	Added resistor values for USB connector
1.15	July 2009	Updated Mechanical Dimensions
1.20	July 2009	Corrected part number

# Contents

<b>1</b>	<b>Introduction.....</b>	<b>1-1</b>
1.1	General Description .....	1-1
1.2	Hardware Description.....	1-1
1.3	Performance Specifications .....	1-1
<b>2</b>	<b>Features.....</b>	<b>2-1</b>
2.1	Protocols .....	2-1
2.2	Security .....	2-1
2.3	Additional Features .....	2-1
<b>3</b>	<b>Typical Applications .....</b>	<b>3-1</b>
<b>4</b>	<b>Connector Pin Description .....</b>	<b>4-1</b>
4.1	Pin Numbers.....	4-1
4.2	J8 Pin Functional Description.....	4-2
4.3	J9 Pin Functional Description.....	4-2
<b>5</b>	<b>Interfaces.....</b>	<b>5-1</b>
5.1	J8 Serial Interface .....	5-1
5.2	J9 SPI Interface.....	5-1
5.3	J9 USB Interface .....	5-1
<b>6</b>	<b>Electrical Specifications .....</b>	<b>6-2</b>
6.1	Absolute Maximum Ratings .....	6-2
6.2	DC Operating Characteristics .....	6-2
6.3	AC Operating Characteristics.....	6-3
<b>7</b>	<b>Mechanical Dimensions.....</b>	<b>7-4</b>
<b>8</b>	<b>Evaluation Board .....</b>	<b>8-1</b>
<b>9</b>	<b>Ordering Information .....</b>	<b>9-1</b>
<b>10</b>	<b>Internet Protocol Compliance .....</b>	<b>10-1</b>

# Figures

**Figure 3-4-1: Pin-out for Nano SocketLAN (Bottom View).....4-1**  
**Figure 6-1: SPI Interface Waveforms.....6-3**  
**Figure 5-7-1: Mechanical Dimensions .....7-4**

## Tables

<b>Table 3-1: J8 Connector Signal Description .....</b>	<b>4-2</b>
<b>Table 4-1: Absolute Maximum Ratings.....</b>	<b>6-2</b>
<b>Table 4-2: DC Operating Characteristics .....</b>	<b>6-2</b>
<b>Table 10-1: Internet Protocol Compliance.....</b>	<b>10-1</b>

# 1 Introduction

## 1.1 General Description

Nano SocketLAN™ is a secure serial-to-LAN device server module that also acts as a bridge to connect serial devices to 10/100 Mbit Ethernet LANs. It includes the iChip™ CO2144 IP Communication Controller™ chip and a 10/100BaseT Ethernet PHY. The Nano SocketLAN is packaged in a RoHS-compliant compact form factor and uses a simple header connector for easy assembly or soldering.

The Nano Socket LAN is Pin compatible with the Nano Socket iWiFi, allowing customers to design a single PCB for an easy switch between LAN and WiFi.

Nano SocketLAN offers much more than many other device servers on the market. It acts as a security gap between the application and the network; supports up to 10 simultaneous TCP/UDP sockets; two listening sockets; a web server with two websites; SMTP and POP3 clients; MIME attachments; FTP and TELNET clients, SerialNET™ mode for serial-to-IP bridging, and many more features.

Nano SocketLAN supports the SSL3/TLS1 protocol for secure sockets, HTTPS and FTPS.

Nano SocketLAN minimizes the need to redesign the host device hardware. It easily inserts into headers on the host PCB and includes an onboard RJ45 connector. Minimal or no software configuration is needed for Nano SocketLAN to access the LAN.

Connect One's high-level AT+i™ API eliminates the need to add security and networking protocols and tasks to the host application. The AT+i SerialNET operating mode offers a true plug-and-play mode that eliminates any changes to the host application.

Nano SocketLAN firmware – the IP stack and Internet configuration parameters – are stored in an on-board flash memory. The module is power-efficient: the core operates at 1.2V, while I/Os operate at 3.3V.

The II-EVB-363MS evaluation board provides an easy environment for testing the Nano SocketLAN prior to designing it into your product.

## 1.2 Hardware Description

Size: 38.9 x 24.88 x 20.9 mm

Core CPU: Connect One CO2144, low-leakage, 0.13 micron, clocked at 48MHz

Operating Voltage: +3.3V±10%

Operating Humidity: 90% maximum (non-condensing)

Operating Temperature Range: -40° to 85°C (-40° to 185°F)

Power Consumption: 130mA (typical)  
30mA (PHY shutdown)

Connector: 2 x 10 pin header 2mm pitch

Host Interface: TTL Serial, SPI and USB device.

10/100BaseT Ethernet

RoHS-compliant; lead-free

## 1.3 Performance Specifications

Host Data Rate/Effective TCP throughput:

- Serial mode: 3Mbps / 3Mbps
- SPI mode: 24Mbps / 5Mbps
- USB mode: 12Mbps / 500Kbps

Serial Data Format (AT+i mode):

Asynchronous character; binary; 8 data bits; no parity; 1 stop bit

SerialNET mode: Asynchronous character; binary; 7 or 8 data bits; odd, even, or no parity; 1, 1.5, or 2 stop bits

Flow Control: Hardware (-RTS, -CTS), software flow control or None.

## Internet Protocols

ARP, ICMP, IP, UDP, TCP, DHCP, DNS,  
NTP, SMTP, POP3, MIME, HTTP, FTP  
and TELNET

## Security Protocols

SSL3/TLS1, HTTPS, FTPS, RSA,  
AES-128/256, 3DES, RC-4, SHA-1, MD-5,  
MD-2

## Protocols Accelerated in HW

AES, 3DES and SHA

## Application Program Interface

Connect One's AT+i protocol  
SerialNET mode for transparent serial  
data-to-Internet bridging

## Warranty

One year

## Installation Requirements

The Nano SocketLAN must be installed  
within a full-enclosure device that is safety  
certified.

## 2 Features

### 2.1 Protocols

- Up to 10 simultaneous TCP/UDP sockets and two listening sockets
- HTTP/HTTPS client
- HTTP/HTTPS web server with two on-chip websites: Configuration site and Application site
- FTP and TELNET clients
- DHCP client and server
- PPP Host Interface
- Sending and receiving textual email and binary email with MIME attachments

### 2.2 Security

- Acts as a security gap between the host application and the network
- One secure SSL3/TLS1 socket
- Supports multiple Certificate Authorities and both client-side and server-side authentication
- Secure FTP (over SSL3) and HTTPS clients
- Includes a true hardware random number generator
- AES, 3DES and SHA accelerated in hardware

### 2.3 Additional Features

- Non-volatile, on-chip operational parameter database
- SerialNET mode for serial-to-IP bridging (port server mode)
- Local firmware update via host interface
- Remote configuration and firmware update over the Internet
- Retrieval of time data from a Network Time Server

*Note:* For a detailed description of all available features, see the *AT+i Programmer's Manual*.

## 3 Typical Applications

- Add IP communications over LAN to serial embedded devices.
- Seamlessly replace a dialup or cellular connection with a LAN connection.
- Add SSL security to M2M solutions.
- Pin compatible with the Nano Socket iWiFi allowing an easy switch between LAN and WiFi.

Nano SocketLAN supports several operational modes:

- **SerialNet™ Serial to LAN Bridge** - allowing transparent bridging of Serial or USB over LAN, using a 3Mbps fast UART. This is a true plug-and-play mode that eliminates any changes to the host application.
- **PPP modem emulation** – allowing existing (i.e. modem) designs currently using PPP to connect transparently over LAN.
- **Full Internet Controller mode** – allowing simple MCU to use the Nano SocketLAN's rich protocol and application capabilities to perform complex Internet operations such as E-mail, FTP, SSL, embedded Web server and others. It also acts as a firewall, providing a security gap between the application and the network.
- **Embedded IP Routing** - allowing a single Nano SocketLAN to route data between multiple LAN clients over a single Dialup/Cellular connection (note: SPI must be used as host interface).

## 4 Connector Pin Description

The Nano SocketLAN module includes the iChip CO2144 IP Communication Controller and 10/100 Ethernet PHY with magnetics mounted on a socket form-factor module. Two 10pin headers (J8 and J9) provide Serial, USB or SPI host interfaces and mechanical reinforcement. The module may be soldered or plugged into mating Female headers.

### 4.1 Pin Numbers

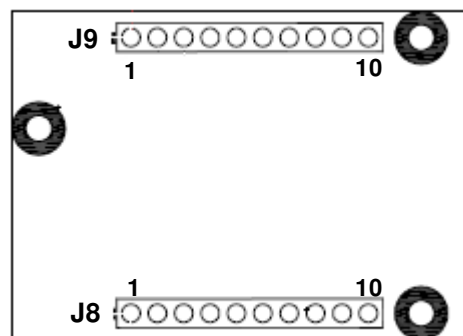

Figure 3-4-1: Pin-out for Nano SocketLAN (Bottom View)

**Connector:** 2 x 10pin Header Male 2mm pitch

**Mate with:** 2 x 10pin Header Female 2mm pitch:

Samtec	# SQT-110-01-F-S
Morethanall	# S-D63-1x10-LF
Weitronic	# 136-1010-10-10-60

or compatible.

## 4.2 J8 Pin Functional Description

Pin	Signal	type	Description
1	GND	Power	
2	V <sub>DD</sub>	Power	
3	RXD0	Input	UART 0 receive
4	TXD0	Output	UART 0 transmit
5	nCTS0	Input	UART 0 clear to send
6	nRTS0	Output	UART 0 request to send
7	DATA_RDY	Output	Data ready <sup>1</sup>
8	MSEL	Input	Mode select <sup>2</sup>
9	nRESET	Input	Reset Module. At Least 10mSec pulse
10	ACT_LINK	Output	LAN Link LED indicator

Table 3-1: J8 Connector Signal Description

## 4.3 J9 Pin Functional Description

Pin	Signal	type	Description
1	nSPI1_CS	Input	SPI 1 chip select for host
2	SPI1_CLK	Input	SPI 1 clock for host (Max 12MHz)
3	SPI1_MISO	Output	SPI 1 slave out for host master in
4	SPI1_MOSI	Input	SPI 1 slave in for host master out
5	SPI1_INT	Output	SPI 1 have data on his buffer
6	Readiness	Output	iChip Ready <sup>3</sup>
7	DDM	Analog	USB device negative
8	DDP	Analog	USB device positive
9	SPEED	Output	Speed LED indicator. "0" - 100M ; "1" -10M
10	GND	Power	

Table 3-2: J9 Connector Signal Description

<sup>1</sup> Indicates new network data is waiting to be read. Details in status report AT+iRP7.  
May be left unconnected.

<sup>2</sup> Enables Rescue Mode / Firmware Update / Force User-profile. May be left unconnected.

<sup>3</sup> Indicates that the boot sequence has completed. May be left unconnected

## 5 Interfaces

### 5.1 J8 Serial Interface

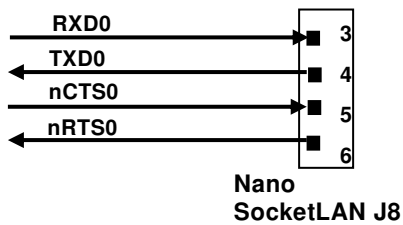

Note: If UART is not used leave TXD0 and RXD0 N.C. and short nCTS0 to nRTS0

### 5.2 J9 SPI Interface

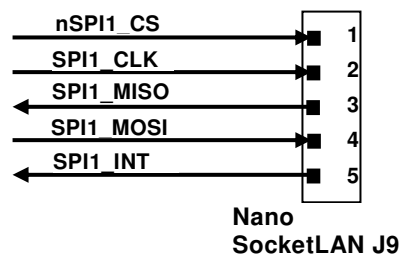

Note: If SPI is not used leave all signals N.C.

### 5.3 J9 USB Interface

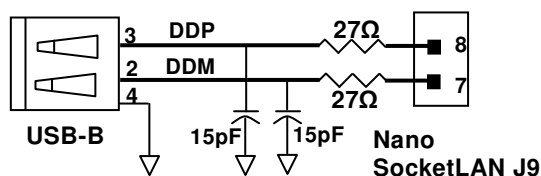

Note: If USB is not used leave all signals N.C.

## 6 Electrical Specifications

### 6.1 Absolute Maximum Ratings

Parameter	Rating
Voltage at any pin with respect to ground	-0.3V to +3.6V
Operating temperature	-40°C to 85°C (-40°F to 185°F)
Storage temperature	-65°C to 125°C (-85°F to 257°F)

Table 4-1: Absolute Maximum Ratings

### 6.2 DC Operating Characteristics

Parameter	Min	Typical	Max	Units
VDD	3.0	3.3	3.6	Volts
High-level Input	2.0		VDD I/O+0.3	Volts
Low-level Input	-0.3		0.8	Volts
High-level Output @2mA	VDD I/O-0.4			Volts
High-level Output @0mA	VDD I/O-0.2			Volts
Low-level Output @2mA			0.4	Volts
Low-level Output @0mA			0.2	Volts
Input leakage current			10	µA
Power supply current from VDD		130	170	mA
Power supply current when Ethernet PHY is shut down		30		mA
Input Capacitance			5.3	pF

Table 4-2: DC Operating Characteristics

(\*) Note: Power supply current as measured in firmware version i2128d804B05.

## 6.3 AC Operating Characteristics

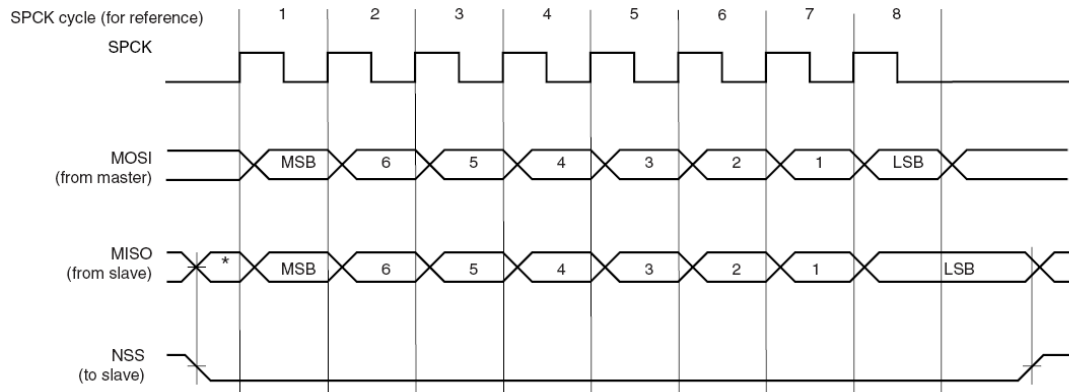

**Figure 6-1: SPI Interface Waveforms**

## 7 Mechanical Dimensions

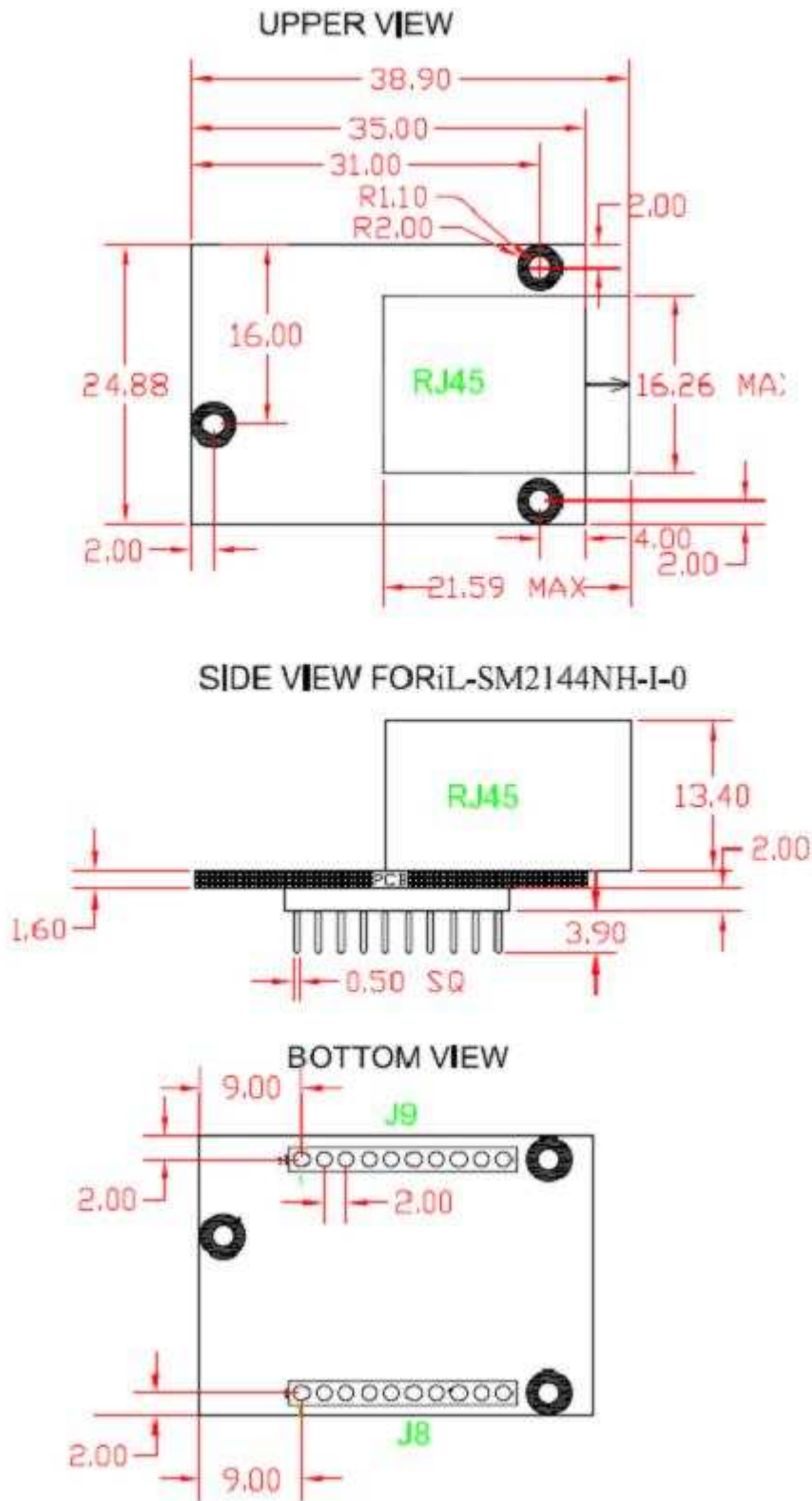

**Note:** All measures are in millimeters

Figure 5-7-1: Mechanical Dimensions

## 8 Evaluation Board

The II-EVB-363-MS evaluation board enables you to evaluate the Nano SocketLAN without changing anything in your current development environment. Using a simple Windows-based application on a PC, you can issue AT+i commands to the iChip CO2144 and get responses.

*Note: The evaluation board supports serial host data rates of up to 1Mbps.*

---

AT+i commands are used to configure parameter values into iChip's flash memory and activate Internet tasks such as email send, sockets, FTP sessions, configuration, and more.

A full description of AT+i commands can be found in the *AT+i Programmer's Manual* on Connect One's website at:

<http://www.connectone.com/support.asp?did=35>

To help you evaluate the Nano SocketLAN, Connect One supplies the iChipConfig Utility. This is a Windows-based application that contains intuitive dialog boxes to fully configure iChip CO2144. It doesn't require any knowledge of AT+i commands. It also contains local firmware update functionality. The iChipConfig Utility allows you to perform specific Internet communication tasks such as sending and receiving emails, activating iChip's websites, entering SerialNET mode, and more. The latest iChipConfig Utility version and user manual can be found on Connect One's website under the Support section.

On board connectors allow a choice of Host interfaces:

- RS232 COM port
- SPI
- USB

## 9 Ordering Information

Ordering Information	
Part Number	Description
iL-SM2144NH-I	Nano SocketLAN module, 2x10 pin header connector
II-EVB-363MS-US-110/220	Evaluation board for Nano SocketLAN. Includes Nano SocketLAN attached to a motherboard's 2x10 pin header connector. The main board includes one male-female RS-232 DB-9 connector for high speed USART, RJ-45, USB, SPI and DC power connector. Specify 110V or 220V power supply. RoHS.

# 10 Internet Protocol Compliance

Nano SocketLAN complies with the Internet standards listed in the following table.

RFC 768	User datagram protocol (UDP)
RFC 791	Internet protocol (IP)
RFC 792	ICMP – Internet control message protocol
RFC 793	Transmission control protocol (TCP)
RFC 821	Simple mail transfer protocol (SMTP)
RFC 822	Standard for the format of ARPA Internet text messages
RFC 826	Ethernet address resolution protocol (ARP)
RFC 959	File transfer protocol (FTP)
RFC 854	TELNET protocol specification
RFC 857	Telnet ECHO option
RFC 858	Telnet suppress go-ahead option
RFC 1034	Domain names (DNS) - concepts and facilities
RFC 1035	Domain names (DNS) - implementation and specification
RFC 1073	Telnet window size option
RFC 1091	Telnet terminal type option
RFC 1321	MD5 message digest algorithm
RFC 1939	Post office protocol - version 3 (POP3)
RFC 1957	Some observations on the implementations of the post office protocol (POP3)
RFC 2030	Simple network time protocol (SNTP)
RFC 2045	Multipurpose Internet mail extensions (MIME) part one: internet message body format
RFC 2046	MIME part two: media types
RFC 2047	MIME part three: message header extensions for non-ASCII text
RFC 2048	MIME part four: registration procedures
RFC 2049	MIME part five: conformance criteria and examples
RFC 2068	Hypertext transfer protocol HTTP/1.1
RFC 2131	Dynamic host configuration protocol (DHCP)
RFC 2132	DHCP options (only relevant parts)
RFC 2228	FTP security extensions
RFC 2246	The TLS protocol version 1.0

*Table 10-1: Internet Protocol Compliance*