

SMC-40 STEP MOTOR CONTROL IC's

SMC-40 Features

The SMC-40 is a microcomputer chip capable of indexing stepping motors. This advanced controller is fast, low power and comes in a small package size.

- NO crystal oscillator required
- NO reset circuit required
- Self contained non-volatile memory
- Maximum step rates above 65,000 SPS
- Non-volatile memory for stand alone operation
- Multiple axis control from a single COM port
- Limit and Home inputs
- Go and soft stop inputs
- Six user ports
- Moving/Driver Enable output
- Small 28 pin PLCC28 and TSSOP28 package size



Available single chip (I²C) peripherals

- Additional NV (EEPROM) memory
- Analog input processor
- Encoder feedback processor

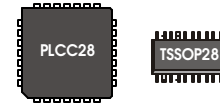

Actual Size

Minimum Circuit Requirements

Only a few components are necessary to create a complete single axis controller. All user inputs and outputs are 3-5 volt logic and should be appropriately buffered.

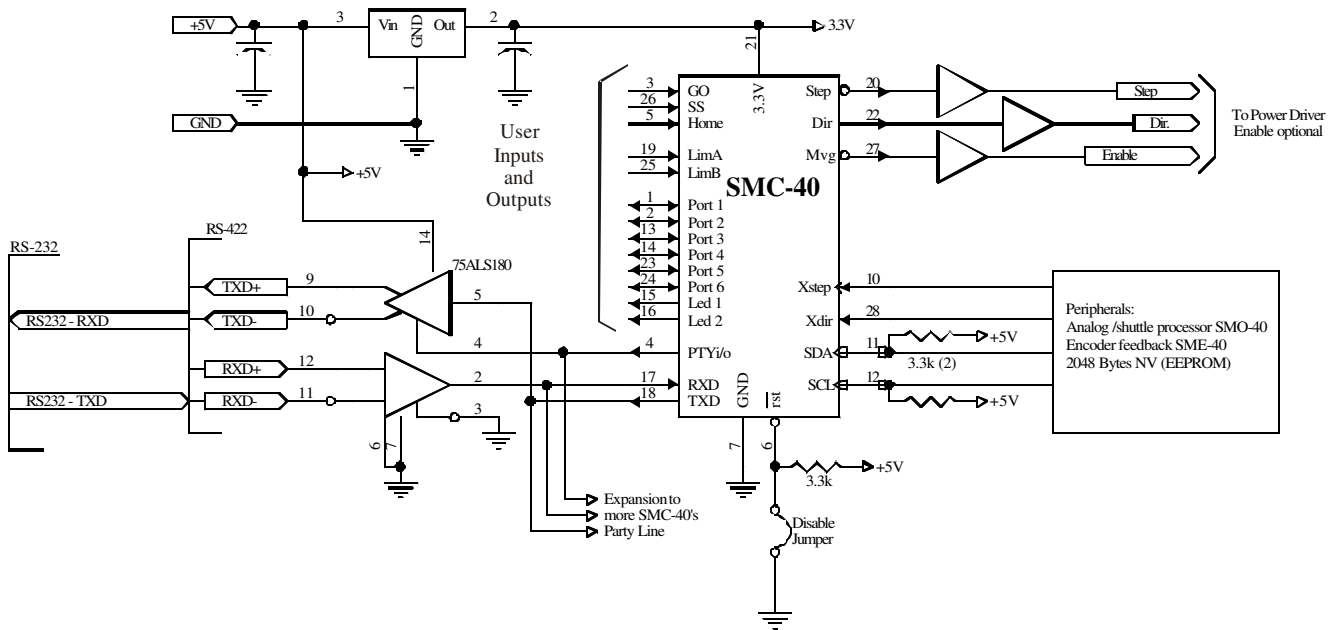

Pin Description

28 PIN PLCC

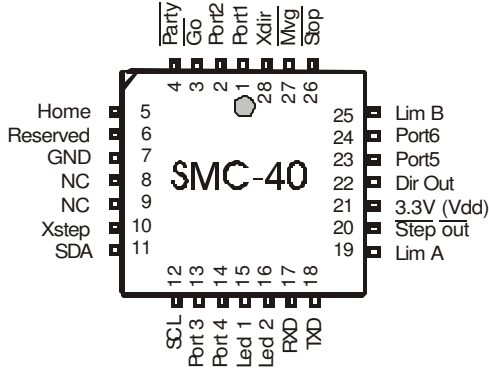

28 PIN TSSOP

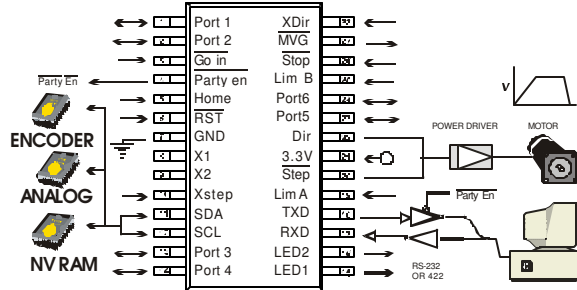

Note: Signal pin numbers are the same for either package.

Pin	Name	Function
1	Port1	General purpose input or output port
2	Port 2	General purpose input or output port
3	GO	Input starts user program at address zero
4	Party	Output enables RS-422 bus driver
5	Home	Input used for home routine, can also be read as input
6	Reset	Input – pull to high
7	GND	Power supply and logic common
8	Xtal1	Not currently used (oscillator is built in)
9	Xtal2	Not currently used (oscillator is built in)
10	Xstep	External step pulse input – analog joystick, encoder
11	SDA	I ² C bus clock for memory expand or other options – requires pull-up
12	SCL	I ² C bus data for memory expand or other options – requires pull-up
13	Port 3	General purpose input or output port
14	Port 4	General purpose input or output port
15	Port 5	General purpose input or output port
16	Port 6	General purpose input or output port
17	RXD	Serial data input – from host computer
18	TXD	Serial data output – to host computer
19	Lim A	Travel Limit input, invertible
20	Step	Output to driver – pulse (65K SPS or square wave 32K SPS)
21	3.3V	Power supply input – 25Ma maximum
22	Dir	Direction control to driver
23	Led 1	Optional activity LED
24	Led 2	Optional activity LED
25	Lim B	Travel limit input, invertible
26	Stop	Input stops executing user program
27	MVG	Output indicates moving, can be 'off' delayed, invertible
28	Xdir	External direction input, used with Xstep (pin 10) input

Command Summary

Mnemonic / Command / Comment / NV Bytes				Mnemonic / Command / Comment / NV Bytes			
^C	Software Reset		0	1	Calibrate	AutoCal & Set	2
^N	Name Axis		0	2	Unused		2
^P	Party Line Mode	^C resets	0	3	Dead Zone (1-255)	Set analog dead band	2
ESC	Abort/Terminate		0	4	Acel/dcel (0-255,0-255)	Option ramp	3
				5	Start Speed (1-255)	Joystick initial speed	2
				6	Top speed (1-255)	Limit highest joy speed	2
				7	Hysterisis (1-255)	Prevent speed dither	2
'	Copywrite	AMS		8	Divider (1-255)	Option speed scale	2
?	Test			9	Read A2D	Display joy voltage	2
(Spare			:	Set Delta		2
)	Spare			:	Get Status		2
*	Spare			<	A2D JAM (engineer)		2
+	CW Index (1-8388607)	Fixed	4	=	Test Z (engineering)		
,	Test			>	Spare		
-	CCW Index (1-8388607)	Fixed	4	[NV Read (addr, 0-255)	Show 0 to 255 bytes	3
.	Spare (period)			\	NV Write (addr, 0-255)	Write to NV address	0
/	Repeat	Repeat last command	0]	Read Limits		2
@	Soft Stop	Decel if moving and stop	1	^	Read Moving Status	Non zero = moving	1
A	Port I/O (0-129)	Read/Write user ports	2	a	Spare		
B	Unused			b	Spare		2
C	Erase Memory	Clear NV, reset defaults	0	c	Spare	Clear over current shutdown	1
D	Divide Step Rates (0-255)	Scale index jog sw, etc	2	d	Encoder Deadband	EFB dead zone	
E	Settle delay	Delay before current setback	2	e	Encoder Enable (lines)	Encoder line count (typ 400-500)	
F	Find Home	Seek home sensor	3	f	Spare		
G	GO (address,1)	Execute user program	3	g	Branch	Branch on port 1-4	2
H	Motor Resolution	Set 1/5 or 1/10 step	2	h	Usteps/Rev	Microstep size	
I	Initial SPS (0-65k)	Basic start SPS	3	i	Special Trip Restart		5
J	Jump (address,0-255)	"Go to" n times	4	j	Jump1 (address, 0-255)	2nd jump counter available	4
K	Ramp Slope (0-255,0-255)	Acceleration, deceleration	3	k	Special Trip Initiate	Position, port	5
L	Loop on Port (addr, cond)	Repeat until low/high	4	l	Set Options	Invert lim, etc	2
M	CV Move ($\pm 50,000$)	Motion with ramping	3	m	Mode Set	Analog joystick, encoder	2
N	Test			n	Spare		
O	Set Origin (0 ± 8388607)	Set position counter	3	o	Set encoder position	Origin	
P	Program (address)	Enter/exit programming	0	p	Spare		
Q	List Program (address)	List programmed commands	0	q	Spare		
R	Absolute Index	Move to absolute position	4	r	Stall Retries	Encoder feedback	
S	Store Parameters	Save basic, analog and encoder	0	s	Sample Distance	Sample every 'n' full steps	
T	Trip Point (0 +8388607, addr)	Trigger commands	5	t	Tolerance (0-100%)	Stall sensitivity	
U	Reserved			u	Print Character	u 13= CR	2
V	Slew Speed	SPS in index command	3	v	Hunt Speed	Speed for encoder hunting	
W	Wait, (delay)	10ms increments, special when 0	3	w	Spare		
X	Examine Parameters	X1=basic, X2= joy, X3 encoder	0	x			
Y	Set Current (0-100,0-100)	Run / Hold current 0-100%	3	y	Lock EFB		
Z	Display Step Position (0,1)	Readout (continuous)	2	z	Read Encoder Position		

Peripheral Device Overview.

Three peripheral devices, the SMO-40, SME-40 and NV2048, are available to enhance the functionality of the SMC-40 controller. These “slave” devices communicate over the standard I²C wire bus. Like the SMC-40, these products stand-alone and do not require external crystals, memory or reset circuitry.

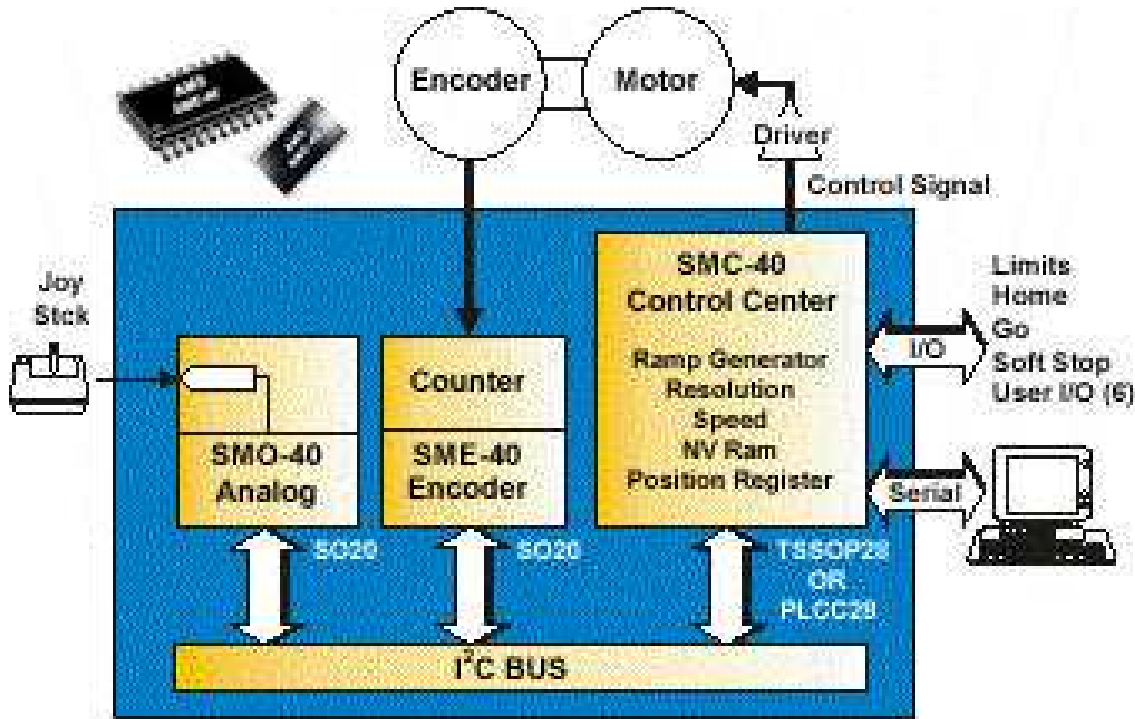

Two of the devices are low power controllers powered by 5-volts and are supplied in a 20-pin (SO20) small outline surface mount package.

SMO-40 Analog “Joystick” Interface- In addition to the analog input, remote step and direction or quadrature A/B logic signal inputs are available.

SME-40 Encoder Interface- Provides servo like position control and error detection.

The third device, **NV2048**, adds 248 bytes of serial EEPROM to expand program storage beyond the 512 bytes already contained in the SMC-40.

None of these devices are necessary for SMC-40 operation. The SMC-40 will detect and install these devices at power-up reset. Simple interface to the SMC-40 “master” processor requires only four or five connections.

SMC-40 Specifications

DC Characteristics

Parameter	Description	Condition	Min	Typ	Max	Units
I _{dd}	Power supply current			15	25	Ma
V _{dd}	Logic supply voltage			3.3	3.6	V
V _{in max}	Absolute maximum	Any pin	-5		5.5	
V _{il}	Input low Schmitt threshold		0.73	1.32		V
I _{il}	Input low current	V _{in} =0.4V			-50	µa
V _{ith}	Input high Schmitt threshold			1.98	2.31	V
I _{ih}	Input high current	V _i =v _{cc} -1.5			500	µa
V _{ol}	Output low voltage	I _{ol} =3.2ma			0.3	V
V _{oh}	Output high voltage	Ext pull-up			5.5	V
I/O Max	Output current per I/O pin				20	Ma

AC Characteristics

Parameter	Description	Min.	Typ	Max.	Units
Baud Rate	8 bits, no parity, 1 start, 1 stop		9600		
Step Rate	Range (internal clock)	57		65000	SPS
Step Pulse Width	Output to driver	5		7	µs
Swl	Limit/home switch response	2			Step Clk

Operating Temperature: -40° to +85° C

Non-Volatile Memory Operation

Instruction	Condition	Typ	Units
Fetch and execute cycle	Loop	1.7	Ms
Save parameters	Store	63	Ms

SMC-40 Prototype Kit

The SMC-40 is a derivative of the control IC used in Advanced Micro Systems IBC-400 control module, making the IBC-400 a low cost way to evaluate designs without the initial prototype expense.



The SMC-40 prototype kit includes:

- 1 each- IBC-400 Step Motor Control Module
- 1 each- BLC-400 Mounting Base
- 1 each- SIN-11 Serial Adapter and Cable

Low cost options for Analog Control (SMO-40) and Encoder Feedback (SME-40) (shown here) are also available.

Ordering Information

- SMC-40P..... 28 Pin PLCC package Step Motor Control IC
- SMC-40T..... 28 Pin TSSOP package Step Motor Control IC
- SMO-40..... 20 Pin SO20 package Analog Control IC
- SME-40..... 20 Pin SO20 package Encoder Feedback IC
- SMC-40PK..... SMC-40 Prototype Kit
- SMC-40PK-A.... SMC-40 Prototype Kit with Analog Control
- SMC-40PK-E.....SMC-40 Prototype Kit with Encoder Feedback
- SMC-40PK-AE... SMC-40 Prototype Kit with Analog Control and Encoder Feedback