

# SAX / DAX

## SINGLE and DUAL AXIS STEP MOTOR CONTROL SYSTEMS



### OVERVIEW

Models SAX (Single Axis) and DAX (Dual Axis) are full function stepper motor control systems. These units are designed for a wide variety of industrial applications that require precise, reliable and cost effective motion control. The SAX/DAX are based on the integration of AMS's high performance step and direction controllers, 2.5 amp per phase programmable current chopper drivers and integral 40 volt power supply.

Communication is through the use of high level commands issued via RS-232 or RS-422 protocol. Built-in intelligence and memory (2K bytes per axis) make it simple to execute programs from a host computer, dumb terminal or stand-alone configuration.

The small chassis size with finned heat sink, built-in fan and convenient A.C. power entry module simplifies design integration. Extensive signal buffering, optical isolation and a differential serial communications interface provide optimal reliability in industrial environments.

### BLOCK DIAGRAM

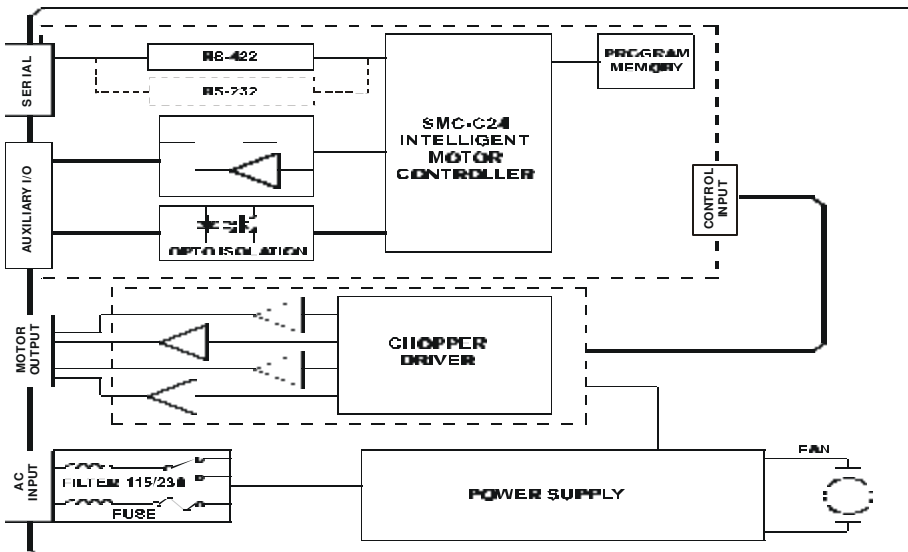

### PERFORMANCE FEATURES

- *Low cost, small size*
- *Serial communication up 32 axis*
- *Assignable serial address*
- *Speeds up to 23,000 SPS*
- *Full/half step mode sequence*
- *Speeds alterable "on the fly"*
- *Programmable accel/decel ramps*
- *Programmable run/hold current*
- *Five buffered user ports*
- *2K bytes of non-volatile memory*
- *Optically isolated home/limits*
- *Single step attribute*
- *Read position while moving*
- *Self-contained home routine*
- *Dual speed jog inputs*
- *Go and soft stop inputs*
- *Programmable trip point*

### SERIAL INTERFACE

Each module features full duplex serial communications. An RS-422 Party Line interface uses a differential transmission and receiver pair to ensure reliable communication in industrial environments. This protocol permits simultaneous communication (to 32 axes) with minimum command processing latency.

### PROGRAMMABLE CURRENT

Each axis has a programmable current feature that controls motor winding current to within 1% resolution. Independent settings for "RUN" and "HOLD" currents permit full motor torque when stepping. Automatic power down to the hold current value minimizes motor power dissipation when the system is not operating.

### PROGRAMS

Using a host computer or dumb terminal, programs (up to 2K bytes per axis) can be stored in non-volatile memory. For stand-alone use there is a "GO" switch input. Additional input ports can test and branch to multiple motion sub-routines. Two programmable outputs are available to drive solid state relays and other devices. A separate "TRIP" function provides automatic program branching when a specified motion is passed. Additional control inputs include soft stop, dual speed jog and step by step monitoring of travel limits to protect expensive hardware.

### ASCII BAUD RATES

The baud rate for communication is factory set at 9600 BPS. Other options include; 300, 1200, 2400, 4800, 19.2k and 38.4k BPS.

**AUXILIARY INPUT AND OUTPUT**

Twenty contact header connectors provide auxiliary inputs and outputs. Buffered signals use optical isolation or TTL buffers.

Signal	Type	Signal	Type
Port 2	Input	+5v	Power
Port 4	Output	Home	Input*
Moving	Output	Limit A	Input*
Port 5	Output	Limit B	Input*
Port 3	Input	Jog-	Input
Port 1	Input	Jog +	Input
Jog	Input	Trip	Output
GND	Power	Soft Stop	Input
Go	Input	Port 4	Input
+5v	Power	Optocom	PS Input

\*Optically isolated

**COMMANDS**

ASCII	Description
ESC	Abort/Terminate
@	Soft Stop
^C	Reset
+	Index in Plus Direction
-	Index in Minus Direction
[	Read NV Memory
]	Read Limits, Hardware
\	Write to NV Memory
^	Read Moving Status
A	Port Read/Write
B	Jog Speed, Slow/Fast
C	Restore/Initialize
D	Divide Step Rates
E	Enable Auto Power Down
F	Find Home (SPS)
G	GO from Address
I	Initial Velocity (SPS)
J	Jump to Address
K	Ramp Slope
L	Loop on Port
M	Move at a Constant Speed
O	Set Origin
P	Program Mode
Q	Query Program
R	Index to Target Position
S	Store Parameters
T	Set Trip Point
V	Slew Velocity (SPS)
W	Wait "N" Milliseconds
X	Examine Parameters
Z	Display Position

**POWER ENTRY MODULE**

The power entry module, located on the front panel, provides an internationally approved A.C. power connector, built-in RFI line filter, fuse and voltage selection option. The line filter traps undesirable noise on the A.C. power line and stops it from entering or exiting the SAX/DAX. A UL/CSA approved line cord is supplied with each unit.

**RS-232 TO RS-422 ADAPTERS**

The optional SIN-8 or SIN-10 adapter modules are used to convert single ended RS-232 communication signals to differentially driven RS-422 levels. A switch on the module selects between Single mode for de-bug and setup, and Party Line mode for multi-axis (up to 32) communication from a single COM port.

**EASI DISKETTE**

All units include a software diskette with program editor, syntax checker/loader, source code ("C"), pull-down menus, dumb terminal emulation, "Quick Basic" programs and speed, distance, accel/decel plots.

**PHYSICAL SPECIFICATIONS**

Size: 4"W x 4"H x 10.7"L  
 Weight: (SAX) 4 lbs. 10 oz.  
 (DAX) 6 lbs. 8 oz.  
 Operating Temp: 0 to 55 degrees C

**ELECTRICAL SPECIFICATIONS**

AC Power Input: 120-240VAC/50-60Hz @ 90VA  
 Power Supply: 40Vdc  
 Chop Rate (Internal Driver): 20 KHz

Description	Min	Typ	Max	Unit
Motor Drive Current	0.2	2	2.8	Amps
<b>Output Signals</b>				
High Level (Voh)		5	15	Volts
Low Level (Vol)			0.3	Volts
Low Current (Iil)			30	Ma.
<b>Input Signals</b>				
High Level (Vih)	3.6		5.2	Volts
Low level (Vil)			0.8	Volts
Low Current (Iil)			2	Ma.
<b>Optical Inputs</b>				
LED Current			5	Ma.
LED Drop			1.5	Volts
Series Resistor		1k		Ohm
RS-422 Input Level		5	25	Volts
RS-422 Outputs		5	25	Volts
RS-232 Loads			1	Axis
RS-422 Load		2	32	Axis

The RS-422 drivers are rated for EAI RS-485 transmission and limits receiver count to 32 with a (max) cable length of 4,000 ft. RS-232 units are rated for one receiver and a (max) cable length of 50 feet.

**ACCESSORIES**

- SIN-7/SIN-9: RS-232 Serial Adapter (25 Pin /9 Pin)
- SIN-8: RS-232 to RS-422 Serial Line Converter
- SIN-10: Intelligent Serial Line Converter
- AM Series Step Motors

