

CCB-25

3 AMP/PHASE STEPPER MOTOR DRIVER AND INTELLIGENT CONTROLLER

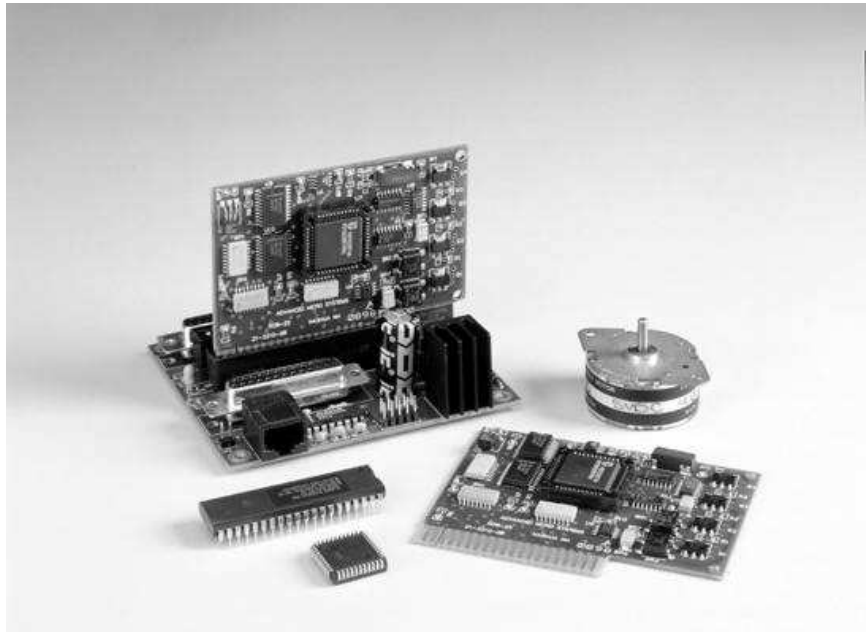

OVERVIEW

The CCB-25 is a low cost driver and smart controller board suitable for operating small stepper motors. It utilizes a flexible phase sequence generator and unipolar power drivers with ratings up to 3 amps per phase. This all-in-one package is designed for OEM applications using high volume production linear actuators, rotary steppers and solenoid or valve drivers. Built in phase step sequences include Full, Half, and Wave drives. A custom, user sequence capability provides a means to sequence 8 states with up to four devices.

The CCB-25 has an instruction set of over 30 commands that include loop on port, count delays, and set/clear ports. In addition to 6 general-purpose ports, jog, limit and home sensor inputs are also available.

The CCB-25 has several features not found in other controllers. In addition to the customizable phase sequence, auxiliary step pulse/direction inputs allow motion generation via external pulse sources, with limit switch protection and position counter tracking.

For evaluation and medium volume production, a companion "mini-mother" board simplifies product interface. The dual axis board has an RS-232 interface, expandable for multiple axes. The communication, power and I.O. signal connectors provide for real-world interface.

FEATURES

- *Small in size*
- *3 amp current output*
- *Absolute/relative position commands*
- *Bi-directional ramping between speeds*
- *User I.O. ports; 4 inputs and 3 outputs*
- *Speeds to 23,000 steps per second*
- *Speed alterable "on the fly"*
- *Soft decelerate stop command & input*
- *Motion output signal*
- *Receive/send commands while moving*
- *Step register of over 16M steps*
- *Enable signal polarity (programmable)*
- *Special "Home" function at any step rate*
- *Read position counter while moving*
- *Limit and home switch inputs*
- *2k non-volatile memory*
- *19.2k Baud selectable*
- *Programmable trip point*
- *Selectable "Party*
- *Line" serial mode*
- *Limit switch polarity (programmable)*
- *16-way branch (on ports 1-4)*

TERMINAL INTERFACE

By using a simple RS-232 buffer, motion sequences can be programmed from a standard terminal or host PC. Command lines consist of an ASCII character followed by a number. The input line editor provides a user-friendly interface. The DCMB (mother board) includes an RS-232 interface.

PARTY LINE MODE

"Party Line" communication protocol is required when a host computer application, other than "dumb" terminal mode, is used. This protocol greatly reduces communication time and supports between 1 and 60 axes of motion connected in parallel from a single serial port.

NON-VOLATILE MEMORY

2k byte of non-volatile memory is available via the Go command to store user programs for future execution. Any number of programs may co-exist, limited only by the available memory space. By implementing non-volatile memory, all parameters, such as initial velocity, ramp, step mode, etc., may be set as defaults then modified "on the fly" during program execution.

RESET

Upon hardware reset all parameters (set by commands B,D,E,H,I,K,T,V) most recently saved are down-loaded into the working registers of the controller. Both Jog and Go inputs are then active. During reset all outputs are off.

TRIP POINT

The trip point is a programmable position that allows pre-defined operations to be triggered when the motor position matches the established trip point position. During motion the position counter is continuously updated and compared to the programmed trip position.

EASI DISKETTE

AMS provides free application development software; featuring:

- Program Editor
- Syntax Checker Loader
- Microsoft "C" Source Code
- Pull-Down Menus
- Dumb Terminal Emulation
- Quick Basic Information Program
- Speed, Distance, Accel/Decel Plots

SUMMARY OF COMMANDS

ASCII	Range	Description	Bytes
ESC	N/A	Abort/Terminate	
A	0-129	Port Set/Increment/Read	2
B	0-255, 0-255	Jog Speed/30: Slow, Fast	3
C	0-8	Restore, Clear Page	
D	0-255	Divide Factor	2
E	0-15	Enable, Limit Sense	2
F	0/1, ±0-23,000	Find Home: Sense Speed	3
G	0-2,048, 0/1	Go (Address/Branch), Trace	3
H	0 - 8	Select phase table	2
I	14-23,000	Initial Velocity-SPS	3
J	0-2,047, 0-255	Jump To Address,	4
K	0-255, 0-255	Ramp Slope	3
k	0-63	Trip Output Values	2
L	0-2048, 0-9	Loop On Port Condition	3
M	±14-23,000	Constant Velocity-SPS	3
O	±0-8,388,607	Set Origin	4
P	0-2,047	Program Mode	
Q	0-2,047	Query Program	
R	±0-8,388,607	Relative Move	4
S	N/A	Store Parameters	1
T	±0-8,388,607	Set Trip Point	4
V	14-23,000	Slew Velocity-SPS	3
W	0-65, 535	Wait n Milliseconds	3
X	N/A	Examine Settings	
Z	0/1	Read Position Once/Repeat	1
+	0-16,777,215	+ Step Command	4
-	0-16,777,215	- Step Command	4
\	0-2,047	Write To NV Memory	
[0-2,047	Read NV Memory	
]	N/A	Query Hardware Status	1
^	N/A	Query Motion Status	1
@	N/A	Soft Stop	1

PHASE SEQUENCE

The H command sets the phase switching sequence:

Sequence	1	2	3	4	5	6	7	8
Full (H0)	1010	1001	0101	0110	1010	1001	0101	0110
Half (H1)	1010	1000	1001	0001	0101	0100	0110	0010
Wave (H2)	1000	0001	0100	0010	1000	0001	0100	0010
Bin. (H3)	0000	1000	0100	1100	0010	1010	0100	1110
Res 0 (H4)	0010	0010	0010	0010	0010	0010	0010	0010
Res 1 (H5)	0011	0011	0011	0011	0011	0011	0011	0011
Res 2 (H6)	1010	1010	1010	1010	1010	1010	1010	1010
Res 3 (H7)	0110	0110	0110	0110	0110	0110	0110	0110

ELECTRICAL SPECIFICATIONS

D.C. Characteristics: (Vcc= 5V ±10%)

Description	Condition	Min	Max	Unit
Icc: Supply current			40.0	Ma
Vil: Input low voltage		-0.5	0.8	V
Iil: Input low current	Vil=0.45V		-500.0	µa
Vih: Input high voltage		2.0	Vcc+0.5	V
Vol: Output low voltage	Iol=1.6ma		0.45	V
Voh: Output high voltage	Ioh= -80µa		2.4	V

Drive Outputs

Description	Min	Max	Unit
4 unipolar transistors (continuous)		3.0	Amp
Motor Power Supply (Vmm):			
Bypass internal regulator (regulated)		5	Vdc
Using internal regulator (standard)	8	28	Vdc

BLOCK DIAGRAM - PHYSICAL DIMENSIONS (3.38 x 2.58 inches)

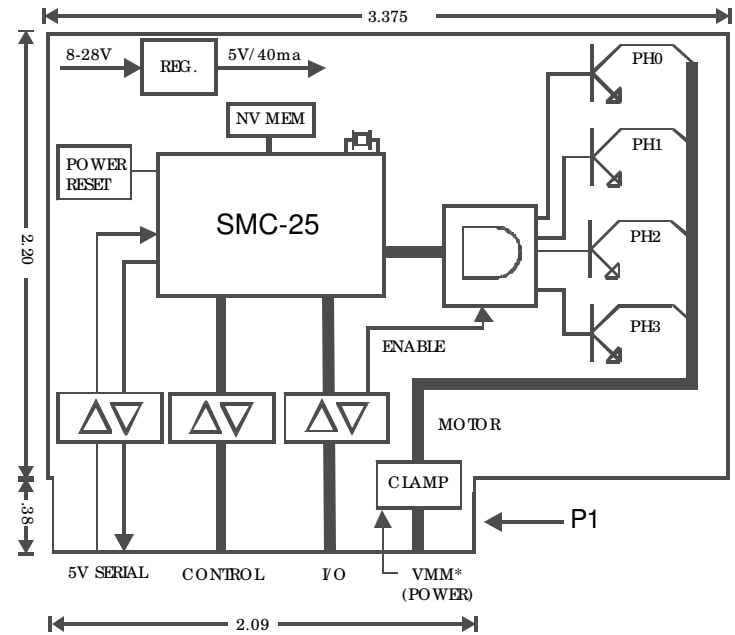

P1 (40 PIN EDGE CONNECTOR) SIGNALS

Pin	Name	Funct.	Sig.	Pin	Name	Funct.	Sig.
1	Gnd	Power	Com	2	N/C		
3	Port 4	Input	5v	4	Home	Input	5v
5	Moving	Output	OD	6	Limit A	Input	5v
7	Port 5	Output	5v	8	Limit B	Input	5v
9	Port 3	Input	5v	10	Jog 2 In	Input	5v
11	Port 1	Input	5v	12	Jog 1 In	Input	5v
13	Jog	Input	5v	14	Port 6	Output	5v
15	Port 2	Input	5v	16	Soft Stop	Input	5v
17	Go	Input	5v	18	Port 4	Output	5v
19	Vcc 5v	In/Out	5v	20	Ext. Dir.	Input	OD
21	Dir.	Output	OD	22	Step	Output	5v
23	Ext Step	Input	5v	24	Enable	Input	5v
25	Party	Input	5v	26	Gnd	Power	Com
27	Vcc 5v	In/Out	5v	28	TXD	Output	5v
29	RXD	Input	5v	30	N/C		
31	Ph 3	Output	Vm	32	Ph 3	Output	Vm
33	Ph 2	Output	Vm	34	Ph 2	Output	Vm
35	Ph 1	Output	Vm	36	Ph 1	Output	Vm
37	Ph 0	Output	Vm	38	Ph 0	Output	Vm
39	Vm	Power	12-20v	40	Gnd	Power	Com

SIGNAL PIN DESCRIPTIONS

Input Hardware

Unless otherwise stated, all inputs are 0-5 volt logic, with 10k pull-up resistors to Vcc. A 3.3k series resistor affords some protection from input surges to the CMOS series input buffers.

Output Hardware

Unless otherwise stated, all outputs are 0-5 volt logic. Open drain outputs have 10k pull-up resistors to Vcc.

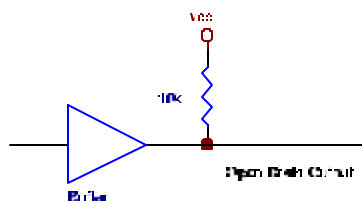

A small series resistor affords some protection to the output of the 74HC buffers.

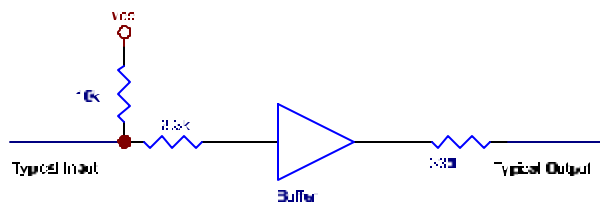

WARNING! Exceeding the input or output ratings will damage the CCB-25 and may void any warranty.

Pin#

- 1, 26, 40 **Power Gnd** is common for power supply and all signals.
- 39 **Vmm Input : (Power Supply)**
 - a) Supplies clamp voltage for output transistor protection.
 - b) Supplies a low voltage 5 volt regulator for logic power (Vmm range: 8 volts to 28 volts maximum).
- 11, 15, 9, 3 **Four General-Purpose 5 Volt Input Ports** for applications such as reading switches or other signals.
- 18, 7, 14 **Three General-Purpose 5 Volt Output Ports** for applications such as valve control or logic signals.
- 4 **Home Input** is used by the Find Home command. It may be read by the host as a general-purpose input.
- 5 **Moving:** an open drain status output low while moving. It may be or'ed with other axis.
- 6, 8 **Limit Switch Inputs** inhibit motion in pertinent direction only.
- 10, 12, 13 **Jog Control** provides a dual speed jog in both directions.
- 17, 16 **Go and Soft Stop Inputs** for control of pre-stored sequences.
- 21, 22 **Step and Direction Outputs** for use with external power drivers or devices such as position display.
- 20, 23 **External Step and Direction Inputs** for "slave" or remote signals. The motor steps in the selected direction in response to each step pulse. The position counter tracks the position and limit switches are operative. Erratic step rates must not produce stall condition
- 24 **Driver Chop Input** has a built in pull-DOWN resistor. Applying a logic High will shut off all output transistors, bypassing the micro controller.
- 25 **Party Line Select Input:** A low will place the pre-addressed axis into the Party Line communications mode.
- 28, 29 **TXD Out and RXD In:** These 5 volt serial signals are used for programming and interface with a host computer.
- 31, 32 **Phase 3 Drive Out: ***
- 33, 34 **Phase 2 Drive Out: ***
- 35, 36 **Phase 1 Drive Out: ***
- 37, 38 **Phase 0 Drive Out: ***

*These outputs are used to drive the step motor. The step sequence is determined by the selectable state table within the controller or non-volatile memory.

2 AXIS MOTHER BOARD (MODEL DCMB)

The DCMB is an accessory to the CCB-25. It contains the interface for one or two axis of motion control. The expansion connector provides the ability to add more axis in a microprocessor based system.

- Two axis interface
- Expansion connector for multi-axis
- 1 amp 5 volt regulator for additional load
- DB25 connector for input/output signals
- DC or 9-18 VAC input for low cost power
- Separate motor and power supply inputs
- RJ45 connector for RS-232 input

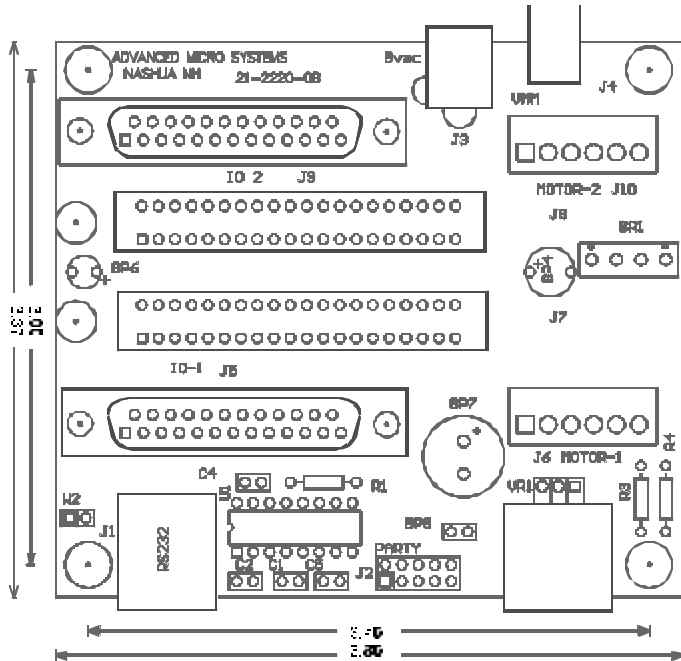

An RS-232 input converts standard serial voltages to TTL levels to drive up to 10 axis using Advanced Micro System's party line protocol. The open drain TXD outputs from each axis are wire-or'd, providing a party line communication method. Prior to operation each axis must be assigned a one character name that is stored in the CCB-25 NV memory. Removing the "party" jumper and inserting one axis at a time facilitates name assignment.

DCMB CONNECTORS

J1 - RS232 Interface

The J1 modular RJ45 connector serves as an RS-232 interface. The receiver and transmitter signals meet EIA specifications. TTL serial data levels are connected to the expansion bus (J2) and both CCB-25 edge connectors. An available "SIN-7A" adapter module and cable allows convenient plug compatibility to a standard 25 pin computer "D" connector.

Pin	Signal
1	Moving
2	Gnd
3	RXD (from computer)
4	TXD (to computer)
5,6,7,8	N/C

J2 - TTL Expansion Bus

J2 is a 10 contact ribbon cable connector that allows multiple axis to be interconnected without additional electronic hardware. The cable length between each additional DCMB should be as short as possible, not exceeding 6 inches.

Pin	Signal	Pin	Signal
1	Gnd	2	Vcc
3	N/C	4	N/C
5	RXD -TTL	6	N/C
7	TXD-OD	8	Mvg -OD
9	Vcc	10	Gnd

All signals are 5v logic levels.

J3 - AC Input

A standard 5.5 mm jack provides input options for low cost AC power transformers. A 9V (1 amp or higher) AC transformer can be used for typical 12Vdc motors. A DC supply may also be applied but approximately 1.5 volts will be lost in the 1 amp rectifiers. The unregulated voltage (approx. 12Vdc) is available on J4.

J4 - DC Input

This input can be used as a power input in place of J3.

Pin	Signal
1	Vmm (8-28 Vdc)*
2	Gnd (0 volts)

*Voltage levels below 8 volts require a separate 5 volt source. For 5 volt operation VMM and VCC can be connected to a single power supply.

J6 Motor Connector

A 6 pin power connector is designed to accept each wire from a 6 conductor motor.

Pin	Signal
1	Ph 3
2	Ph2
3	Ph1
4	Ph0
5	Vmm (center tap Ph0 and Ph1)
6	Vmm (center tap Ph2 and Ph3)

I.O. 1, and I.O. 2 Input/Output Signals

Two convenient DB25 connectors provide access to all input and output signals. All signals are 5v logic levels rated at 1ma source or sink. Inputs have a 10k pull-up resistor.

Pin	Name	Funct.	Sig.	Pin	Name	Funct.	Sig.
1	Port 2	Input	5v	14	Vcc	Power	5v
2	Port 4	Input	5v	15	Home	Input	5v
3	Moving	Out	OD	16	Limit A	Input	5v
4	Port 5	Out	5v	17	Limit B	Input	5v
5	Port 3	Input	5v	18	Jog 1	Input	5v
6	Port 1	Input	5v	19	Jog 2	Input	5v
7	Jog Spd	Input	5v	20	Port 6	Output	5v
8	Gnd	Power	Com	21	Soft Stp	Input	5v
9	Go	Input	5v	22	Port 4	Output	5v
10	Ext Dir.	Input	5v	23	Dir.	Output	OD
11	Step	Output	5v	24	Gnd	Power	Com
12	Ext Step	Input	5v	25	Gnd	Power	Com
13	Chop	Input	5v				