



# U74LVX4053

CMOS IC

## Triple 2-Channel Analog Multiplexer/Demultiplexer

### DESCRIPTION

The **U74LVX4053** is a high speed, low-voltage drive analog multiplexer/demultiplexer using silicon gate CMOS technology. In 3V and 5V systems these can achieve high-speed operation with the low power dissipation that is a feature of CMOS.

The **U74LVX4053** offer analog/digital signal selection as well as mixed signals with a 4-Channel×2 configuration.

The switches for each channel are turned on by the control pin digital signals.

Although the control signal logical amplitude ( $V_{CC}-GND$ ) is small, the device can perform large-amplitude ( $V_{CC}-V_{EE}$ ) signal switching.

For example, if  $V_{CC}=3V$ ,  $GND=0V$  and  $V_{EE}=-3V$ , signals between -3V and +3V can be switched from the logical circuit using a signal 3V power supply.

All input pins are equipped with a newly developed input protection circuit that avoids the need for a diode on the plus side (forward side from the input to the  $V_{CC}$ ). As a result, for example, 5V signals can be permitted on the inputs even when the power supply voltage to the circuits is off. As a result of this input power protection, the **U74LVX4053** can be used in a variety of applications, including in the system which has two power supplies, and in battery backup circuits.

### FEATURES

- \* Low ON resistance:  $R_{ON}=22\Omega$ (Typ.)( $V_{CC}-V_{EE}=3V$ )
- \*  $R_{ON}=15\Omega$ (Typ.)( $V_{CC}-V_{EE}=6V$ )
- \* High Speed:  $t_{pd}=3ns$  (Typ.)( $V_{CC}=3V$ )
- \* Low power Dissipation:  $I_{CC}=4\mu A$  (Max.)( $T_A=25^\circ C$ )

- \* Input level:  $V_{IL}=0.8V$ (Max.)( $V_{CC}=3V$ )
- $V_{IH}=2.0V$ (Min.)( $V_{CC}=3V$ )
- \* Power down protection is provided on all control inputs
- \* Pin and function compatible with U74HC4053

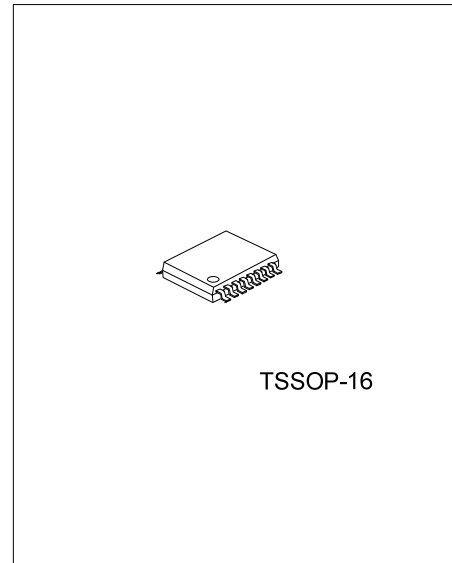

TSSOP-16

### ORDERING INFORMATION

Ordering Number		Package	Packing
Lead Free	Halogen Free		
U74LVX4053L-P16-T	U74LVX4053G-P16-T	TSSOP-16	Tube
U74LVX4053L-P16-R	U74LVX4053G-P16-R	TSSOP-16	Tape Reel

<p>U74LVX4053L-P16-T</p>	<p>(1) Packing Type (2) Package Type (3) Lead Free</p>	<p>(1) T: Tube, R: Tape Reel (2) P16: TSSOP-16 (3) L: Lead Free, G: Halogen Free</p>
--------------------------	--	--

## ■ PIN CONFIGURATION

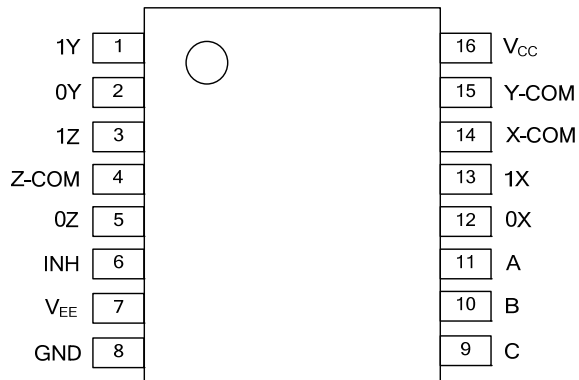

## ■ FUNCTION TABLE

CONTROL INPUTS				"ON" Channel
INH	C	B	A	LVX4053
L	L	L	L	0X,0Y,0Z
L	L	L	H	1X,0Y,0Z
L	L	H	L	0X,1Y,0Z
L	L	H	H	1X,1Y,0Z
L	H	L	L	0X,0Y,1Z
L	H	L	H	1X,0Y,1Z
L	H	H	L	0X,1Y,1Z
L	H	H	H	1X,1Y,1Z
H	X	X	X	None

Note: H: HIGH voltage level; L: LOW voltage level; X: Don't care

■ LOGIC DIAGRAM (positive logic)

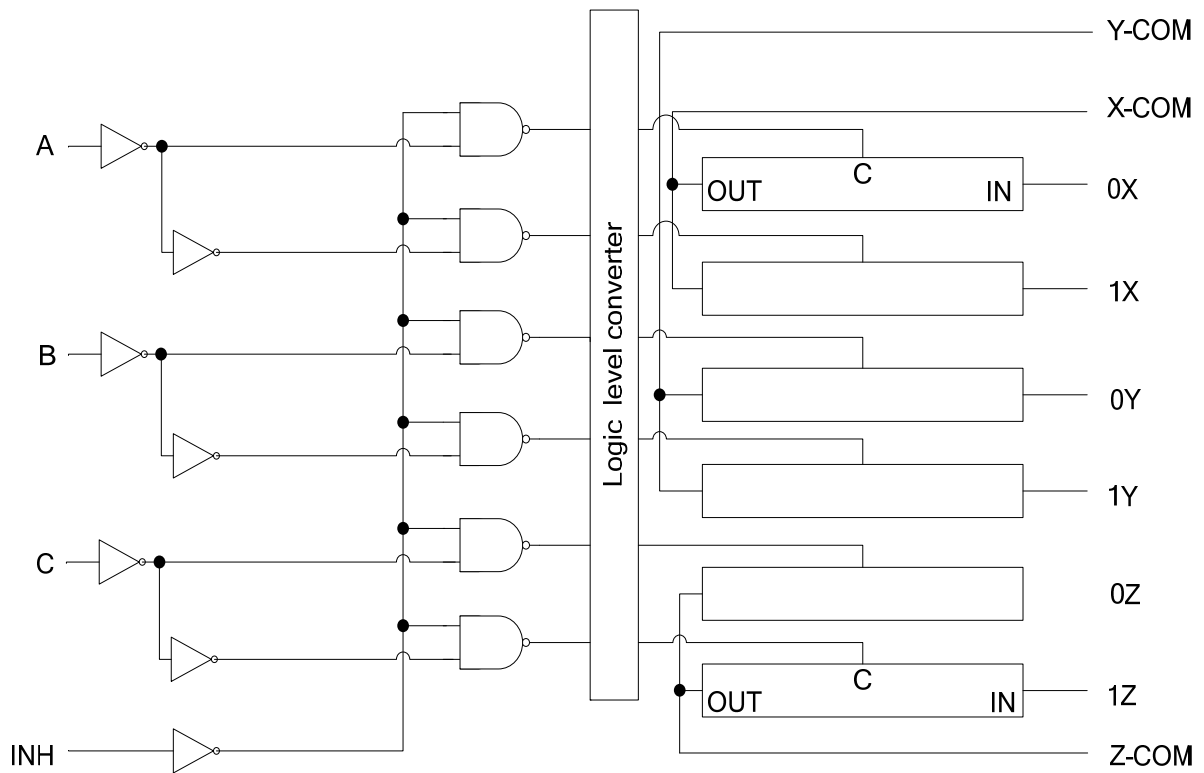

### ■ ABSOLUTE MAXIMUM RATING

PARAMETER	SYMBOL	RATINGS	UNIT
Power Supply Voltage	$V_{CC}$	-0.5 ~ +7.0	V
	$V_{CC} \sim V_{EE}$	-0.5 ~ +7.0	
Control Input Voltage	$V_{IN}$	-0.5 ~ +7.0	V
Switch I/O voltage	$V_{I/O}$	$V_{EE} - 0.5 \sim V_{CC} + 0.5$	V
Input diode current	$I_{IK}$	-20	mA
I/O diode Current	$I_{IOK}$	$\pm 20$	mA
Switch through current	$I_T$	$\pm 25$	mA
DC Vcc or ground current	$I_{CC}$	$\pm 50$	mA
Power dissipation	$P_D$	450	mW
Operating Temperature	$T_{OPR}$	-40 ~ +85	°C
Storage Temperature	$T_{STG}$	-65 ~ +150	°C

Note: Absolute maximum ratings are those values beyond which the device could be permanently damaged. Absolute maximum ratings are stress ratings only and functional device operation is not implied.

### ■ RECOMMENDED OPERATING CONDITIONS

PARAMETER	SYMBOL	TEST CONDITIONS	MIN	TYP	MAX	UNIT
Power Supply Voltage	$V_{CC}$		2.0		6.0	V
	$V_{EE}$		-4		0	
	$V_{CC} \sim V_{EE}$		2		6	
Input Voltage	$V_{IN}$		0		6	V
Switch I/O Voltage	$V_{I/O}$		$V_{EE}$		$V_{CC}$	V
Input Rise and Fall time	dt/dv	$V_{CC} = 3.3V \pm 0.3$	0		100	ns/V
		$V_{CC} = 5V \pm 0.5$	0		20	

■ DC ELECTRICAL CHARACTERISTICS (T<sub>A</sub>=25°C, unless otherwise specified)

PARAMETER		SYMBOL	TEST CONDITIONS	MIN	TYP	MAX	UNIT	
Input voltage	High-level	V <sub>IH</sub>	V <sub>CC</sub> =2V	1.5			V	
			V <sub>CC</sub> =3V	2.0				
			V <sub>CC</sub> =4.5V	3.15				
			V <sub>CC</sub> =6V	4.2				
	Low-level	V <sub>IL</sub>	V <sub>CC</sub> =2V			0.5		
			V <sub>CC</sub> =3V			0.8		
			V <sub>CC</sub> =4.5V			1.35		
			V <sub>CC</sub> =6V			1.8		
ON resistance		R <sub>ON</sub>	V <sub>IN</sub> =V <sub>IL</sub> or V <sub>IH</sub> V <sub>I/O</sub> =V <sub>EE</sub> to V <sub>EE</sub> I <sub>I/O</sub> =2mA	V <sub>CC</sub> =2V, V <sub>EE</sub> =GND		200		Ω
				V <sub>CC</sub> =3V, V <sub>EE</sub> =GND		45	86	
				V <sub>CC</sub> =4.5V, V <sub>EE</sub> =GND		24	37	
				V <sub>CC</sub> =3V, V <sub>EE</sub> =-3V		17	26	
			V <sub>IN</sub> =V <sub>IL</sub> or V <sub>IH</sub> V <sub>I/O</sub> =V <sub>CC</sub> to V <sub>EE</sub> I <sub>I/O</sub> =2mA	V <sub>CC</sub> =2V, V <sub>EE</sub> =GND		28	73	
				V <sub>CC</sub> =3V, V <sub>EE</sub> =GND		22	38	
				V <sub>CC</sub> =4.5V, V <sub>EE</sub> =GND		17	27	
				V <sub>CC</sub> =3V, V <sub>EE</sub> =-3V		15	24	
Difference of ON resistance between switches	ΔR <sub>ON</sub>	V <sub>IN</sub> =V <sub>IL</sub> or V <sub>IH</sub> V <sub>I/O</sub> =V <sub>CC</sub> to V <sub>EE</sub> I <sub>I/O</sub> =2mA	V <sub>CC</sub> =2V, V <sub>EE</sub> =GND		10	25	Ω	
			V <sub>CC</sub> =3V, V <sub>EE</sub> =GND		5	15		
			V <sub>CC</sub> =4.5V, V <sub>EE</sub> =GND		5	13		
			V <sub>CC</sub> =3V, V <sub>EE</sub> =-3V		5	10		
Input/Output Leakage Current (switch off)	I <sub>OFF</sub>	V <sub>OS</sub> =V <sub>CC</sub> or GND, V <sub>IS</sub> =GND or V <sub>CC</sub> , V <sub>IN</sub> =V <sub>IH</sub> OR V <sub>IL</sub>	V <sub>CC</sub> =3V, V <sub>EE</sub> =GND			±0.25	μA	
			V <sub>CC</sub> =3V, V <sub>EE</sub> =-3V			±0.5		
Quiescent Supply Current	I <sub>CC</sub>	V <sub>IN</sub> =V <sub>CC</sub> or GND	V <sub>CC</sub> =3V, V <sub>EE</sub> =GND			4.0	μA	
			V <sub>CC</sub> =3V, V <sub>EE</sub> =-3V			8.0	μA	
Input/Output leakage current (switch on, output open)	I <sub>IN</sub>	V <sub>OS</sub> =V <sub>CC</sub> or GND, V <sub>IN</sub> =V <sub>IH</sub> or V <sub>IL</sub>	V <sub>CC</sub> =3V, V <sub>EE</sub> =GND			±0.25	μA	
			V <sub>CC</sub> =3V, V <sub>EE</sub> =-3V			±0.5		
Control input current	I <sub>IN</sub>	V <sub>IN</sub> =V <sub>CC</sub> or GND	V <sub>CC</sub> =6V, V <sub>EE</sub> =GND			±0.1	μA	

■ **AC ELECTRICAL CHARACTERISTICS** ( $T_A=25^\circ\text{C}$ , Input  $t_R/t_F=3\text{ns}$ ,  $\text{GND}=0\text{V}$ ,  $C_L=50\text{pF}$ )

See Fig. 1, Fig. 2 and Fig. 3 for test circuit and waveforms.

PARAMETER	SYMBOL	TEST CONDITIONS	MIN	TYP	MAX	UNIT
Phase difference between input and output	$t_{pLH}/t_{pHL}$	$V_{CC}=2\text{V}, V_{EE}=\text{GND}$		3.2	6.0	ns
		$V_{CC}=3\text{V}, V_{EE}=\text{GND}$		1.8	3.0	
		$V_{CC}=4.5\text{V}, V_{EE}=\text{GND}$		1.3	1.8	
		$V_{CC}=3\text{V}, V_{EE}=-3\text{V}$		1.1	1.3	
Output enable time (Note 1)	$t_{pZL}/t_{pZH}$	$V_{CC}=2\text{V}, V_{EE}=\text{GND}$		9	17	ns
		$V_{CC}=3\text{V}, V_{EE}=\text{GND}$		5.7	9	
		$V_{CC}=4.5\text{V}, V_{EE}=\text{GND}$		4.5	6	
		$V_{CC}=3\text{V}, V_{EE}=-3\text{V}$		5.8	8	
Output disable time (Note 1)	$t_{pLZ}/t_{pHZ}$	$V_{CC}=2\text{V}, V_{EE}=\text{GND}$		13.5	21	ns
		$V_{CC}=3\text{V}, V_{EE}=\text{GND}$		11.3	15	
		$V_{CC}=4.5\text{V}, V_{EE}=\text{GND}$		10.3	12	
		$V_{CC}=3\text{V}, V_{EE}=-3\text{V}$		10.9	13	
Control input capacitance (Note 2)	$C_{IN}$			5	10	pF
COMMON terminal capacitance (Note 2)	$C_{IS}$	$V_{CC}=3\text{V}, V_{EE}=-3\text{V}$		7	15	pF
SWITCH terminal capacitance (Note 2)	$C_{OS}$	$V_{CC}=3\text{V}, V_{EE}=-3\text{V}$		6	13	pF
Feedthrough capacitance (Note 2)	$C_{IOS}$	$V_{CC}=3\text{V}, V_{EE}=-3\text{V}$		3	6	pF
Power dissipation capacitance (Note 3)	$C_{PD}$	$V_{CC}=6\text{V}, V_{EE}=\text{GND}$		18		pF

Note: 1.  $R_L=1\text{k}$

- $C_{IN}$ ,  $C_{IS}$ ,  $C_{OS}$  and  $C_{IOS}$  are guaranteed by the design.
- CPD is defined as the value of the internal equivalent capacitance of IC which is calculated from the operating current consumption without load.

Average operating current can be obtained by the equation.

$$I_{CC}(\text{OPR})=C_{PD}\times V_{CC}\times f_{IN}+V_{CC}$$

## ■ Analog Switch CHARACTERISTICS (GND=0V, T<sub>A</sub>=25°C) (Note)

PARAMETER	SYMBOL	TEST CONDITIONS	MIN	TYP	MAX	UNIT	
Sine Wave Distortion	THD	R <sub>L</sub> =10k, C <sub>L</sub> =50pF, f <sub>IN</sub> =1k	V <sub>IN</sub> =2Vp-p, V <sub>CC</sub> =3V, V <sub>EE</sub> =0V		0.1	%	
			V <sub>IN</sub> =4Vp-p, V <sub>CC</sub> =4.5V, V <sub>EE</sub> =0V		0.03		
			V <sub>IN</sub> =6Vp-p, V <sub>CC</sub> =3V, V <sub>EE</sub> =-0.3V		0.02		
Frequency response (switch on)	f <sub>MAX</sub>	Adjust f <sub>IN</sub> voltage to obtain 0dBm at V <sub>OS</sub> . Increase fin frequency until dB meter reads -3dB. R <sub>L</sub> =50Ω, C <sub>L</sub> =10pF, f <sub>IN</sub> =1MHz, sine wave (Figure 4)	V <sub>CC</sub> =3V, V <sub>EE</sub> =0V		200	MHz	
			V <sub>CC</sub> =4.5V, V <sub>EE</sub> =0V		200		
			V <sub>CC</sub> =3V, V <sub>EE</sub> =-3V		200		
Feed through attenuation (switch off)		V <sub>IN</sub> is centered at (V <sub>CC</sub> -V <sub>EE</sub> )/2. Adjust input for 0dBm. R <sub>L</sub> =600Ω, C <sub>L</sub> =50pF, f <sub>IN</sub> =1MHz, sine wave (Figure 5)	V <sub>CC</sub> =3V, V <sub>EE</sub> =0V		-45	dB	
			V <sub>CC</sub> =4.5V, V <sub>EE</sub> =0V		-45		
			V <sub>CC</sub> =3V, V <sub>EE</sub> =-3V		-45		
			R <sub>L</sub> =50Ω, C <sub>L</sub> =10pF, f <sub>IN</sub> =1MHz, sine wave	V <sub>CC</sub> =3V, V <sub>EE</sub> =0V			-60
			V <sub>CC</sub> =4.5V, V <sub>EE</sub> =0V		-60		
Crosstalk (control input to signal output)		R <sub>L</sub> =600Ω, C <sub>L</sub> =50pF, f <sub>IN</sub> =1MHz, square wave (t <sub>r</sub> =t <sub>f</sub> =6ns) (Figure 6)	V <sub>CC</sub> =3V, V <sub>EE</sub> =0V		90	mV	
			V <sub>CC</sub> =4.5V, V <sub>EE</sub> =0V		150		
			V <sub>CC</sub> =3V, V <sub>EE</sub> =-3V		120		
Crosstalk (between any switches)		Adjust V <sub>IN</sub> to obtain 0dBm at input. R <sub>L</sub> =600Ω, C <sub>L</sub> =50pF, f <sub>IN</sub> =1MHz, sine wave (Figure 7)	V <sub>CC</sub> =3V, V <sub>EE</sub> =0V		-45	dB	
			V <sub>CC</sub> =4.5V, V <sub>EE</sub> =0V		-45		
			V <sub>CC</sub> =3V, V <sub>EE</sub> =-3V		-45		

Note: These characteristics are determined by design of devices.

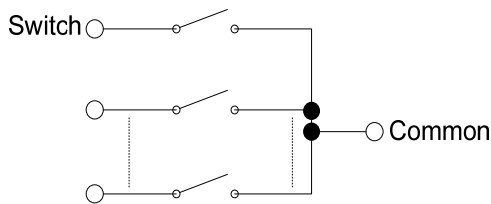

## TEST CIRCUIT AND WAVEFORMS

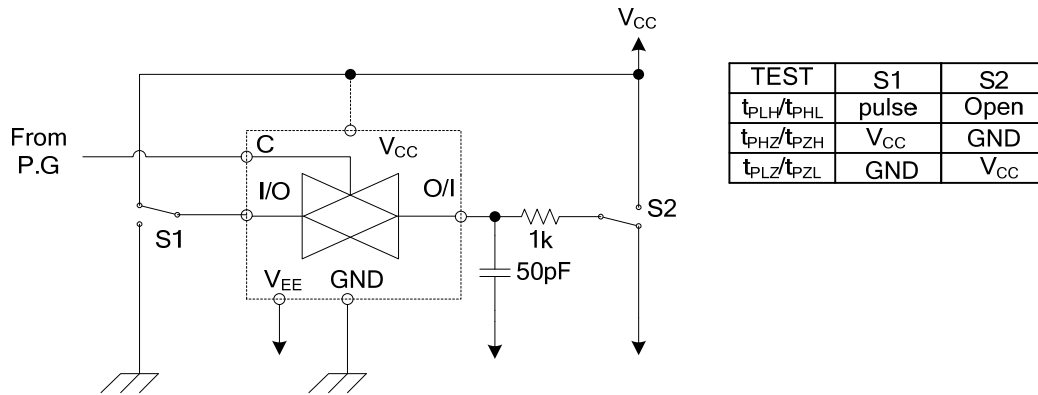

Fig. 1 Load circuitry for switching times.

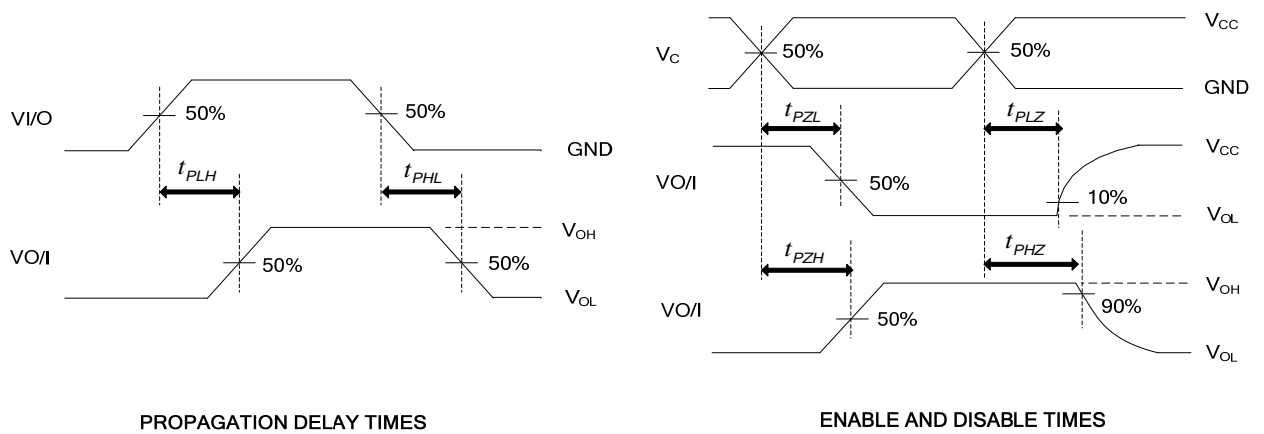
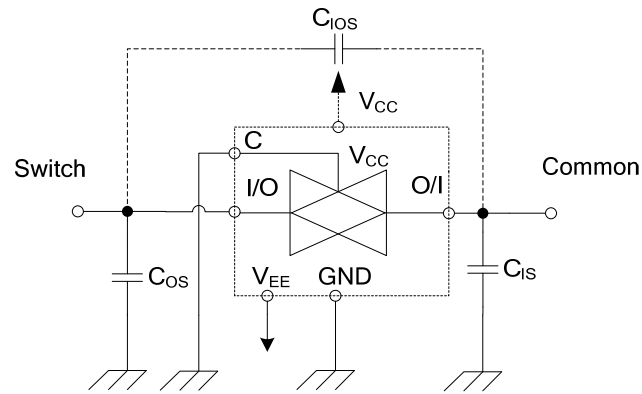
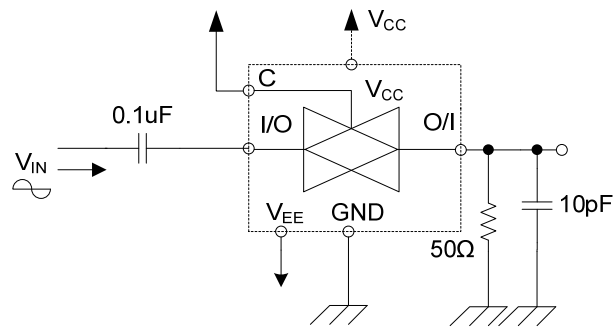

Fig. 2 Propagation delay from input to output and enable, disable times.

## ■ AC TEST CIRCUIT



**Fig. 3** C<sub>IOS</sub>, C<sub>IS</sub>, C<sub>OS</sub>



**Fig. 4** Frequency Response (switch on)

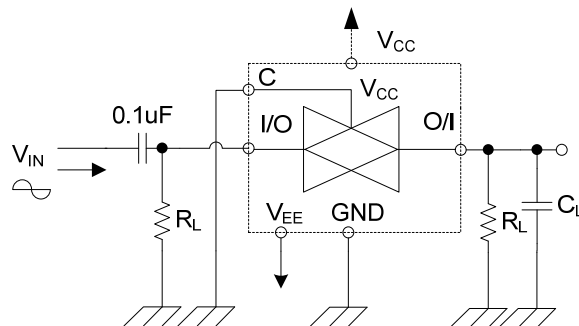

**Fig. 5** Feedthrough

## ■ AC TEST CIRCUIT(Cont.)

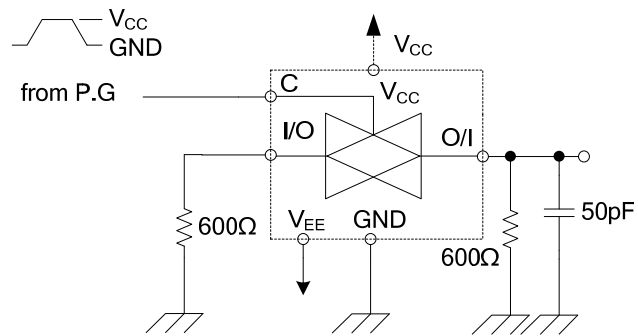

Fig. 6 Cross Talk (control input to output signal)

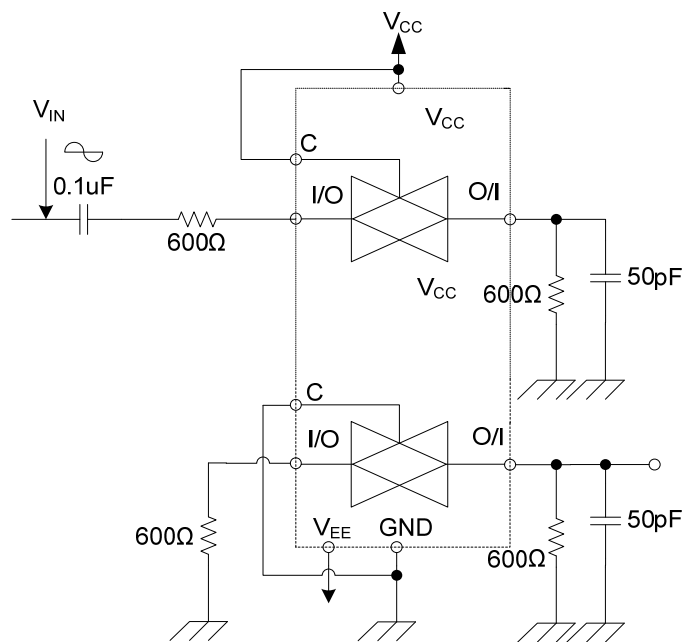

Fig. 7 Cross Talk (between any two switches)

UTC assumes no responsibility for equipment failures that result from using products at values that exceed, even momentarily, rated values (such as maximum ratings, operating condition ranges, or other parameters) listed in products specifications of any and all UTC products described or contained herein. UTC products are not designed for use in life support appliances, devices or systems where malfunction of these products can be reasonably expected to result in personal injury. Reproduction in whole or in part is prohibited without the prior written consent of the copyright owner. The information presented in this document does not form part of any quotation or contract, is believed to be accurate and reliable and may be changed without notice.