



BTB20

Preliminary

TRIAC

20A TRIACS

■ **DESCRIPTION**

The UTC **BTB20** is a 20A triacs, it uses UTC's advanced technology to provide customers with glass passivation, a superior performance in surge current handling and voltage insulated tab, etc.

The UTC **BTB20** is suitable for static switching on inductive or resistive load and phase control application.

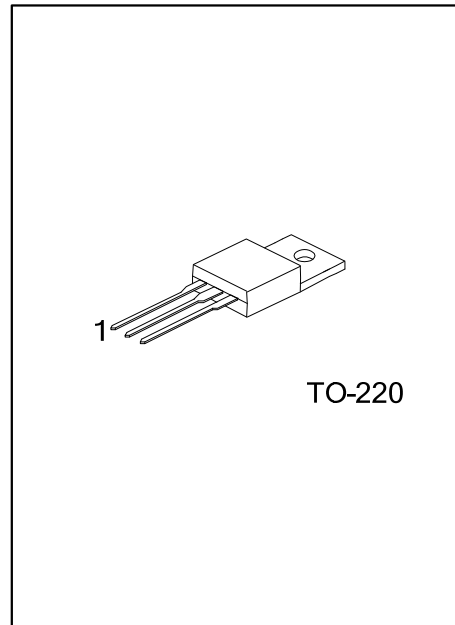

■ **SYMBOL**

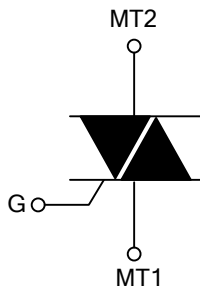

■ **ORDERING INFORMATION**

Ordering Number		Package	Pin Assignment			Packing
Lead Free	Halogen Free		1	2	3	
BTB20L-x-xx-TA3-T	BTB20G-x-xx-TA3-T	TO-220	MT1	MT2	G	Tube

<p>BTB20L-x-xx-TA3-T</p> <p>(1)Packing Type (2)Package Type (3)Sensitivity and type (4)Voltage (5)Lead Free</p>	<p>(1) T: Tube (2) TA3: TO-220 (3) refer to SENSITIVITY AND TYPE (4) 6: 600V (5) L: Lead Free, G: Halogen Free</p>
---	--

■ **SENSITIVITY AND TYPE**

PART NUMBER	VOLTAGE	SENSITIVITY	TYPE
CW	600V	35mA	SNUBBERLESS

■ **ABSOLUTE MAXIMUM RATINGS**

PARAMETER		SYMBOL	RATINGS	UNIT	
RMS On-State Current (Full Sine Wave)		$T_C=70^\circ\text{C}$	$I_{T(RMS)}$	20	A
Non Repetitive Surge Peak On-State Current (Full Cycle, T_J initial= 25°C)	F=50 Hz	$t=10\text{ms}$	I_{TSM}	210	A
	F=60 Hz	$t=8.3\text{ms}$		200	A
I^2t Value for Fusing	$t_p=10\text{ms}$		I^2t	200	A^2s
Critical Rate of Rise of On-State Current $I_G=500\text{mA}$, $dI_G/dt = 1\text{A}/\mu\text{s}$	Repetitive, F=50 Hz	$T_J=125^\circ\text{C}$	di/dt	50	A/ μs
	Non Repetitive			100	A/ μs
Non Repetitive Surge Peak Off-State Voltage	$t_p=10\text{ms}$	$T_J=25^\circ\text{C}$	V_{DSM}/V_{RSM}	$V_{DSM}/V_{RSM}+100$	V
Peak Gate Current	$t_p=20\mu\text{s}$	$T_J=125^\circ\text{C}$	I_{GM}	4	A
Peak Positive Gate Voltage	$t_p=20\mu\text{s}$		V_{GM}	16	V
Average Gate Power Dissipation		$T_J=125^\circ\text{C}$	$P_{G(AV)}$	1	W
Operating Junction Temperature			T_J	-40~+125	$^\circ\text{C}$
Storage Junction Temperature			T_{STG}	-40~+150	$^\circ\text{C}$

Note: Absolute maximum ratings are those values beyond which the device could be permanently damaged. Absolute maximum ratings are stress ratings only and functional device operation is not implied.

■ **THERMAL RESISTANCES**

PARAMETER	SYMBOL	RATINGS	UNIT
Junction to Ambient	θ_{JA}	60	$^\circ\text{C}/\text{W}$
Junction to Case (AC)	θ_{JC}	1.3	$^\circ\text{C}/\text{W}$
Junction to Case (DC)		1.7	$^\circ\text{C}/\text{W}$

■ **ELECTRICAL CHARACTERISTICS** ($T_J=25^\circ\text{C}$ unless otherwise specified.)

PARAMETER	SYMBOL	TEST CONDITIONS	BW			CW			UNIT	
			MIN	TYP	MAX	MIN	TYP	MAX		
Gate Trigger Current (Note 1)	I_{GT}	$V_D=12\text{V}$, $R_L=33\Omega$	ALL	2		50	1		35	mA
Gate Trigger Voltage	V_{GT}		ALL			1.5			1.5	V
Gate Non-Trigger Voltage	V_{GD}	$V_D=V_{DRM}$, $R_L=3.3\text{k}\Omega$, $T_J=125^\circ\text{C}$	ALL	0.2			0.2			V
Holding Current (Note 2)	I_H	$I_T=500\text{mA}$, Gate Open				75			50	mA
Latching Current	I_L	$I_G=1.2I_{GT}$	I-III		50					mA
			II		90					mA
			I-II-III						80	mA
Critical Rate of Rise of Off-State Voltage (Note 2)	dV/dt	$V_D=67\%V_{DRM}$, Gate Open, $T_J=125^\circ\text{C}$		500	750		250	500		V/ μs
Critical Rate of Rise of Off-State Voltage at Commutation (Note 2)	(dV/dt)c	(di/dt)c=20A/ms, $T_J=125^\circ\text{C}$		18	36		11	22		V/ μs

■ **STATIC CHARACTERISTICS**

PARAMETER	SYMBOL	TEST CONDITIONS	MIN	TYP	MAX	UNIT				
Peak On-State Voltage (Note 2)	V_{TM}	$I_{TM}=28\text{A}$, $t_p=380\mu\text{s}$				$T_J=25^\circ\text{C}$			1.70	V
Repetitive Peak Off-State Current	I_{DRM}	$V_{DRM}=V_{RRM}$				$T_J=25^\circ\text{C}$			10	μA
	I_{RRM}					$T_J=125^\circ\text{C}$			3	mA

Notes: 1. Minimum I_{GT} is guaranteed at 5% of I_{GT} max.
2. For both polarities of MT2 referenced to MT1.

UTC assumes no responsibility for equipment failures that result from using products at values that exceed, even momentarily, rated values (such as maximum ratings, operating condition ranges, or other parameters) listed in products specifications of any and all UTC products described or contained herein. UTC products are not designed for use in life support appliances, devices or systems where malfunction of these products can be reasonably expected to result in personal injury. Reproduction in whole or in part is prohibited without the prior written consent of the copyright owner. The information presented in this document does not form part of any quotation or contract, is believed to be accurate and reliable and may be changed without notice.