



BTB04

Preliminary

TRIAC

SENSITIVE GATE TRIACS

■ **DESCRIPTION**

The UTC **BTB04** is a 4A triacs, it uses UTC's advanced technology to provide customers with high commutation performances and voltage insulated tab, etc.

The UTC **BTB04** is suitable for inductive loads, general purpose AC switching and an ON/OFF function in applications such as induction motor starting circuits, for phase control operation in light dimmers and static relays, etc.

■ **FEATURES**

- * Low gate trigger current
- * Low holding current

■ **SYMBOL**

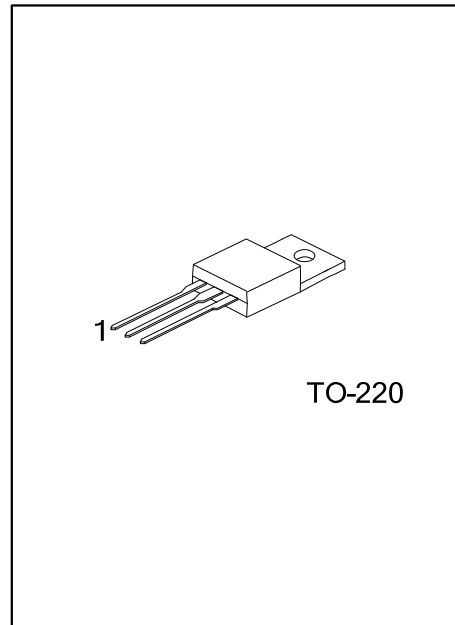
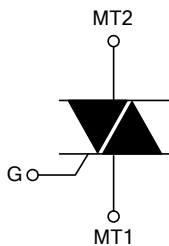

■ **ORDERING INFORMATION**

Ordering Number		Package	Pin Assignment			Packing
Lead Free	Halogen Free		1	2	3	
BTB04L-x-x-TA3-T	BTB04G-x-x-TA3-T	TO-220	MT1	MT2	G	Tube

<p>BTB04L-x-x-TA3-T</p> <p>(1) Packing Type (2) Package Type (3) Sensitivity (4) Voltage (5) Lead Free</p>	<p>(1) T: Tube (2) TA3: TO-220 (3) refer to SENSITIVITY AND TYPE (4) 4: 400V, 6: 600V (5) L: Lead Free, G: Halogen Free</p>
--	---

■ **SENSITIVITY AND TYPE**

PART NUMBER	VOLTAGE		SENSITIVITY	TYPE
	400V	600V		
S		⊙	10mA	STANDARD
D	⊙		5mA	STANDARD
T	⊙	⊙	5mA	STANDARD

⊙: Available

■ ABSOLUTE MAXIMUM RATINGS

PARAMETER		SYMBOL	RATINGS	UNIT
RMS On-State Current (360° Conduction Angle)	$T_C=90^{\circ}\text{C}$	$I_{T(RMS)}$	4	A
Non Repetitive Surge Peak On-State Current (T_J initial= 25°C)	$t_p=8.3\text{ms}$	I_{TSM}	42	A
	$t_p=10\text{ms}$		40	A
I^2t Value	$t_p=10\text{ms}$	I^2t	8	A^2s
Critical Rate of Rise of On-State Current: $I_G=50\text{mA}$, $dI_G/dt=0.1\text{A}/\mu\text{s}$	Repetitive $F=50\text{Hz}$	dI/dt	10	$\text{A}/\mu\text{s}$
	Non Repetitive		50	$\text{A}/\mu\text{s}$
Repetitive Peak Off-State Voltage ($T_J=110^{\circ}\text{C}$)	400 T/D	V_{DRM}/V_{RRM}	400	V
	600 T/S		600	V
Peak Gate Current	$t_p=20\mu\text{s}$	I_{GM}	4	A
Peak Positive Gate Voltage	$t_p=20\mu\text{s}$	V_{GM}	16	V
Peak Positive Gate Power Dissipation	$t_p=20\mu\text{s}$	P_{GM}	40	W
Average Gate Power Dissipation		$P_{G(AV)}$	1	W
Operating Junction Temperature		T_J	-40~+110	$^{\circ}\text{C}$
Storage Junction Temperature		T_{STG}	-40~+150	$^{\circ}\text{C}$

Note: Absolute maximum ratings are those values beyond which the device could be permanently damaged.
Absolute maximum ratings are stress ratings only and functional device operation is not implied.

■ THERMAL RESISTANCES

PARAMETER	SYMBOL	RATINGS	UNIT
Junction to Ambient	θ_{JA}	60	$^{\circ}\text{C}/\text{W}$
Junction to Case for 360° Conduction Angle ($F=50\text{Hz}$) (AC)	θ_{JC}	2.4	$^{\circ}\text{C}/\text{W}$
Junction to Case (DC)		3.2	$^{\circ}\text{C}/\text{W}$

■ ELECTRICAL CHARACTERISTICS

PARAMETER	SYMBOL	TEST CONDITIONS	T			D			S			A			UNIT	
			MIN	TYP	MAX	MIN	TYP	MAX	MIN	TYP	MAX	MIN	TYP	MAX		
Gate Trigger Current	I_{GT}	$V_D=12V$ (DC) $R_L=33\Omega$ $T_J=25^\circ C$	I-II-III			5			5			10			10	mA
			IV			5			10			10			25	mA
Gate Trigger Voltage	V_{GT}	$T_J=25^\circ C$	ALL			1.5			1.5			1.5			1.5	V
Gate Non-Trigger Voltage	V_{GD}	$V_D=V_{DRM}$, $R_L=3.3k\Omega$, $T_J=110^\circ C$	ALL	0.2			0.2			0.2			0.2			V
Time Gate Trigger	t_{GT}	$V_D=V_{DRM}$, $I_G=40mA$, $dI_G/dt=0.5A/\mu s$, $T_J=25^\circ C$	ALL		2			2			2			2		μs
Holding Current (Note 1)	I_H	$I_T=100mA$, Gate Open, $T_J=25^\circ C$				15			15			25			25	mA
Latching Current	I_L	$I_G=1.2I_{GT}$, $T_J=25^\circ C$	I-III-IV		10			10			20			20		mA
			II		20			20			40			40		mA
Peak On-State Voltage (Note 1)	V_{TM}	$I_{TM}=5.5A$, $t_p=380\mu s$, $T_J=25^\circ C$			1.65			1.65			1.65			1.65	V	
Repetitive Peak Off-State Current	I_{DRM}	V_{DRM} Rated, $T_J=25^\circ C$			0.01			0.01			0.01			0.01	mA	
	I_{RRM}	V_{RRM} Rated, $T_J=110^\circ C$			0.75			0.75			0.75			0.75	mA	
Critical Rate of Rise of Off-State Voltage (Note 1)	dV/dt	Linear Slope up to $V_D=67\%V_{DRM}$, Gate Open, $T_J=110^\circ C$		10			10			10			10		$V/\mu s$	
Critical Rate of Rise of Off-State Voltage at Commutation (Note 1)	$(dV/dt)_c$	$(dI/dt)_c=1.8A/ms$, $T_J=110^\circ C$		1			1			5			5		$V/\mu s$	

Note: 1. For either polarity of electrode MT2 voltage with reference to electrode MT1.

UTC assumes no responsibility for equipment failures that result from using products at values that exceed, even momentarily, rated values (such as maximum ratings, operating condition ranges, or other parameters) listed in products specifications of any and all UTC products described or contained herein. UTC products are not designed for use in life support appliances, devices or systems where malfunction of these products can be reasonably expected to result in personal injury. Reproduction in whole or in part is prohibited without the prior written consent of the copyright owner. The information presented in this document does not form part of any quotation or contract, is believed to be accurate and reliable and may be changed without notice.