



RCR2E

Preliminary

CMOS IC

DECODER FOR REMOTE CONTROLLER WITH FIVE FUNCTIONS

DESCRIPTION

The UTC **RCR2E** provides a complete control functions to the remote-controlled toy.

The UTC **RCR2E** has five output pins corresponding with the five actions. The received signals are amplified by the three-stage amplifier, and then the appropriate amplified signals are sampled, fault-tolerantly checked and decoded to control the actions of the remote-controlled toy.

There is an internal oscillator in the UTC **RCR2E** respectively. By adding an external resistor conveniently, the oscillator will be constructed. The oscillator frequency can be adjusted by the external resistor. The relative error between the frequencies of the two on-chip oscillators in the UTC **RCR2E** must be less than $\pm 25\%$.

The auto-power-off function is achieved by an internal counter. The PC output is used to control on/off state of the external power supply. Pressing OFF button can also shut down the power supply. Press on any function button will wake up the chip promptly

FEATURES

- * The UTC **RCR2E** works as decoder
- * RCR2E-A have not ZENER
RCR2E-B built-in 3.6V ZENER
- * Five Pins for five control functions
- * Operating power-supply voltage:
SOP-16: 2.0V ~ 5.0V, DIP-16: 2.5V ~ 5.0V
- * Auto-power-off if no press on any button in 8s or continuously press on any button over 4 minutes
- * Manual-power-off with OFF button
- * On-chip oscillator with an external resistor
- * On-chip reversing amplifiers
- * Low operating current

ORDERING INFORMATION

Order Number		Package	Packing
Lead Free	Halogen Free		
RCR2EL-x-D16-T	RCR2EG-x-D16-T	DIP-16	Tube
RCR2EL-x-S16-T	RCR2EG-x-S16-T	SOP-16	Tube
RCR2EL-x-S16-R	RCR2EG-x-S16-R	SOP-16	Tape Reel

<p>RCR2EL-x-S16-T</p>	<p>(1) T: Tube, R: Tape Reel</p> <p>(2) S16: SOP-16, D16: DIP-16</p> <p>(3) x: refer to I_{CC}</p> <p>(4) L: Lead Free, G: Halogen Free</p>
-----------------------	---

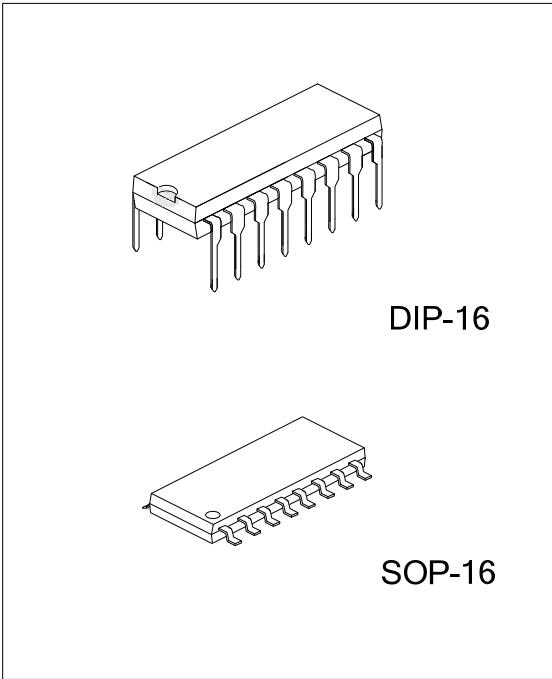

■ PIN CONFIGURATION

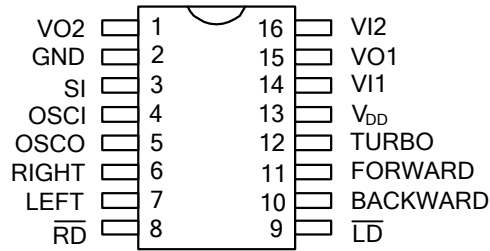

■ PIN DESCRIPTION

PIN NO.	PIN NAME	FUNCTION
1	VO2	Output pin for the amplifier 2
2	GND	Negative power supply
3	SI	Input pin of the encoding signal
4	OSCI	Oscillator input pin
5	OSCO	Oscillator output pin
6	Right	Rightward output pin
7	Left	Leftward output pin
8	\overline{RD}	With Pull-up resistor, rightward function disabled if this pin connected to GND
9	\overline{LD}	With Pull-up resistor, leftward function disabled if this pin connected to GND
10	Backward	Backward output pin
11	Forward	Forward output pin
12	Turbo	Turbo output pin
13	V_{CC}	Positive power supply
14	VI1	Input pin for the amplifier 1
15	VO1	Output pin for the amplifier 1
16	VI2	Input pin for the amplifier 2

■ BLOCK DIAGRAM

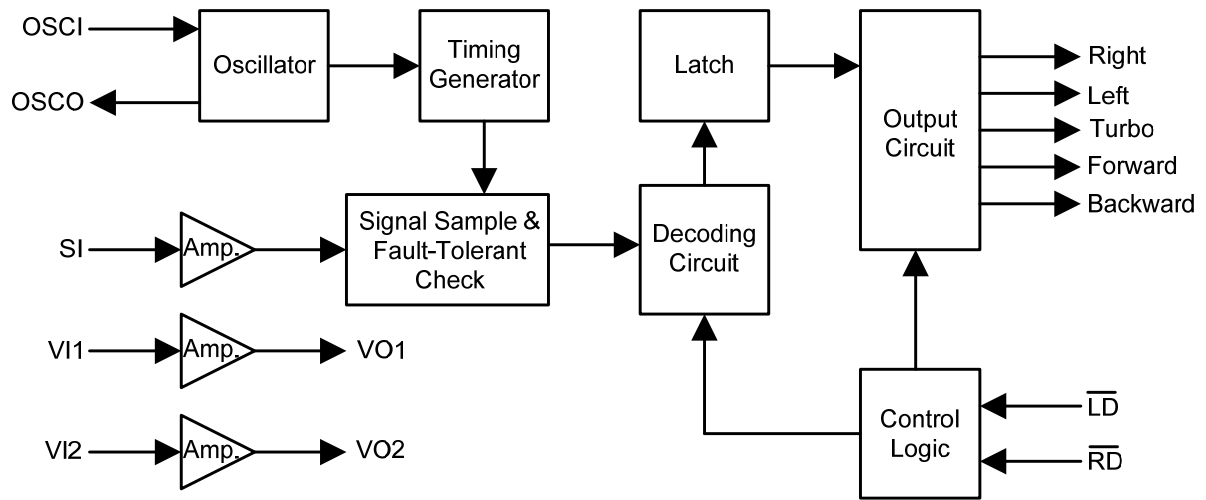

■ ABSOLUTE MAXIMUM RATING

(Above which the useful life may be impaired. For user guidelines, not tested)

PARAMETER	SYMBOL	RATINGS	UNIT
Supply Voltage to Ground Potential (Inputs & V _{CC} Only)		-0.5 ~ +6.0	V
Supply Voltage to Ground Potential (Outputs & D/O Only)		-0.5 ~ +6.0	V
DC Input Voltage	V _{IN}	-0.5 ~ +6.0	V
DC Output Current	V _{DD}	20	mA
Ambient Temperature with Power Applied	T _A	-10 ~ +40	°C
Power Dissipation	P _D	500	mW
Storage Temperature	T _{STG}	-25 ~ 85	°C

Note: Stresses greater than those listed under ABSOLUTE MAXIMUM RATINGS may cause permanent damage to the device. This is a stress rating only and functional operation of the device at these or any other conditions above those indicated in the operational sections of this specification is not implied. Exposure to absolute maximum rating conditions for extended periods may affect reliability.

■ ELECTRICAL CHARACTERISTICS

PARAMETER		SYMBOL	TEST CONDITIONS	MIN	TYP	MAX	UNIT
Operating Voltage	DIP-16	V _{CC}		2.5	4.0	5.0	V
	SOP-16			2.0		5.0	
Supply Current	RCR2E-A	I _{CC}	Output unloaded			0.5	mA
	RCR2E-B					15	mA
Input Low Voltage		V _{IL}	Guaranteed Logic LOW level			0.3×V _{CC}	V
Input High Voltage		V _{IH}	Guaranteed Logic HIGH level	0.7×V _{CC}			V
Input Low Current	Pin 3, 8, 9	I _{IL}	V _{IL} =0V, ON state			-60	μA
Input High Current	Pin 3	I _{IH}	V _{IH} =4V, ON state			60	μA
	Pin 8, 9					10	
Input Current	Pin 14, 16	I _I	V _{IH} =0~4V, ON state			±10	μA
Output Low Current	Pin 1, 5, 15	I _{OL}	V _{OUT} =0.5V	200		850	μA
	Pin 6, 7, 10, 11, 12			2			mA
Output High Current	Pin 1, 5, 15	I _{OH}	V _{OUT} =3.5V	-200		-850	μA
	Pin 6, 7, 10, 11, 12			-500			

Note: Over the Operating Rating, 0°C < T_A < 70°C, V_{CC} = 4V.

■ AC ELECTRICAL CHARACTERISTICS

PARAMETER		SYMBOL	TEST CONDITIONS	MIN	TYP	MAX	UNIT
Oscillator Frequency (Note 2)		f _{OSC}	T _A =25°C	102	128	154	kHz
Oscillator Frequency Fluctuation	DIP-16	f _{MAX} -f _{MIN}	T _A =25°C, V _{CC} =2.5~5V			15	kHz
	SOP-16		T _A =25°C, V _{CC} =2.0~5V			10	
SI Pin Receive Sensitivity (V _{pp})		V _{SI}	Guaranteed Effective Decoding	300			mV
Cycle Time of Function Code		t _{FUN}	f _{OSC} =128kHz	0.75	1	1.25	ms
Cycle Time of Start Code		t _{STA}	f _{OSC} =128kHz	1.5	2	2.5	ms

Note: 1. Over the Operating Rating, 0°C < T_A < 70°C, V_{CC} = 4V.

2. The relative error between the frequencies of the two on-chip oscillators in the UTC RCR2E must be less than ±25%.

■ CODE FORMAT

(W1 is used for function codes, W2 for start codes)

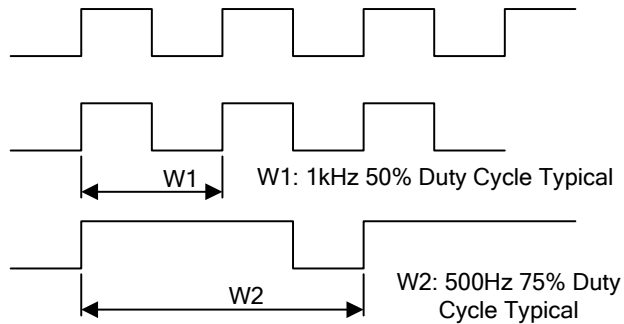

■ WORD FORMAT

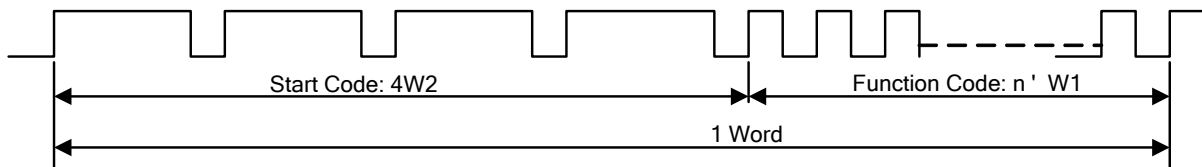

■ ENCODING AND DECODING TIMING

W2, W2, W2, W2, (n)xW1, W2, W2, W2, W2, (n)xW1, W2, W2, W2, W2, (n)xW1, W2, W2, W2, W2, (n)xW1

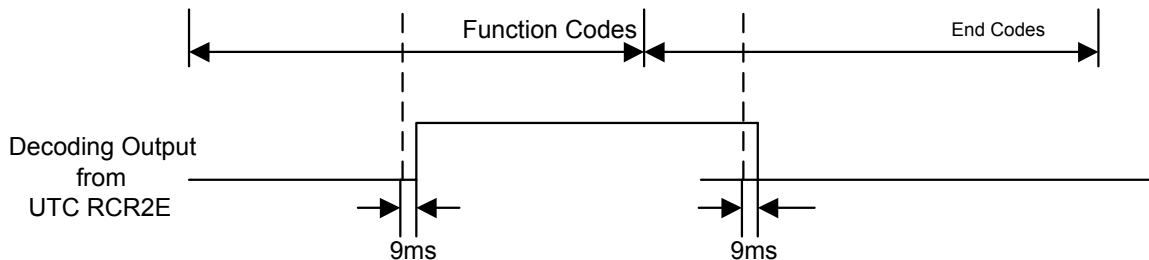

■ ENCODING INPUT AND DECODING RESULT

Number of Function Codes (n) W1	Decoding Results
4	End Code
10	Forward (Pulse)
16	Forward (High level)
22	Turbo
28	Forward (High level) & Left
34	Forward (High level) & Right
40	Backward
46	Backward & Right
52	Backward & Left
58	Left
64	Right

■ TYPICAL APPLICATION CIRCUIT

Typical Application of the UTC RCR2E-B For Receive Circuit With Five Functions

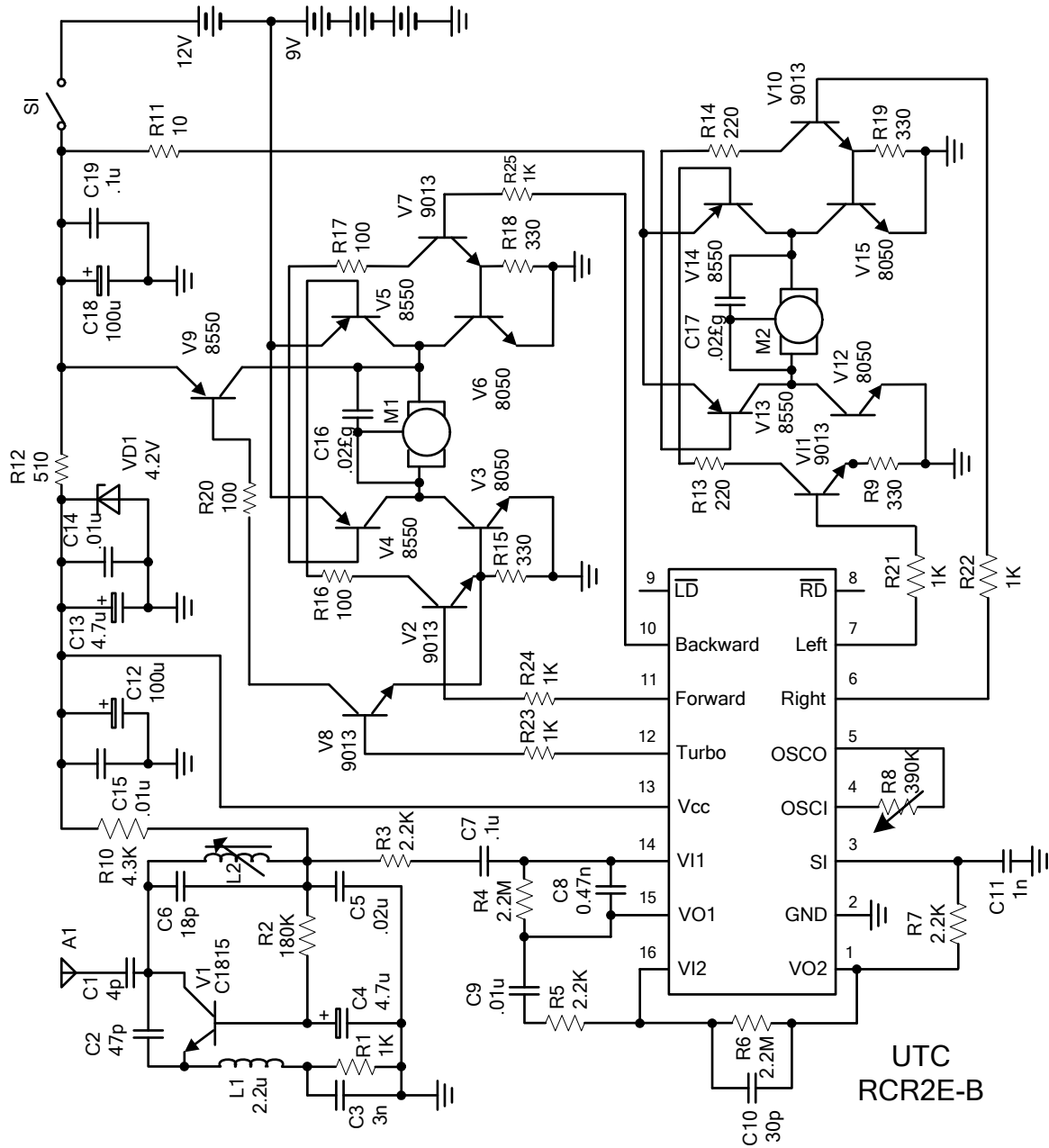

UTC assumes no responsibility for equipment failures that result from using products at values that exceed, even momentarily, rated values (such as maximum ratings, operating condition ranges, or other parameters) listed in products specifications of any and all UTC products described or contained herein. UTC products are not designed for use in life support appliances, devices or systems where malfunction of these products can be reasonably expected to result in personal injury. Reproduction in whole or in part is prohibited without the prior written consent of the copyright owner. The information presented in this document does not form part of any quotation or contract, is believed to be accurate and reliable and may be changed without notice.