



PA6204

Preliminary

CMOS IC

1.7-W MONO FULLY DIFFERENTIAL AUDIO POWER AMPLIFIER

DESCRIPTION

The UTC PA6204 is a mono fully-differential audio amplifier, capable of delivering 1.7W of continuous average power to an 8-Ω BTL load with less than 10% distortion from a 5V power supply.

The UTC PA6204 is ideal for PDA/smart phone applications due to features such as -80-dB supply voltage rejection from 20Hz to 2kHz, improved RF rectification immunity, small 20mm² total PCB area, and a fast startup with minimal pop. The device operates from 2.5V to 5.5V, drawing only 4mA of quiescent supply current.

The UTC PA6204 is suitable for diverse applications, such as PDAs, Wireless or cellular handsets, Portable devices.

FEATURES

- * 1.7W into 8Ω from a 5-V supply at THD=10% (Typ.)
* 2.5V-5.5V operation
* Low supply current: 4mA typ at 5V
* Ultra low current shutdown mode
* Only three external components
- Improved PSRR (-80dB) for direct battery operation
- Fully differential design reduces RF rectification
- -63dB CMRR eliminates two input coupling capacitors
* Fast startup with minimal pop

ORDERING INFORMATION

Table with 4 columns: Ordering Number (Lead Free, Halogen Free), Package, Packing. Rows include PA6204L-SM1-R, PA6204G-SM1-R, PA6204L-S08-R, PA6204G-S08-R, PA6204L-S08-T, PA6204G-S08-T.

Note: xx: Output Voltage, refer to Marking Information.

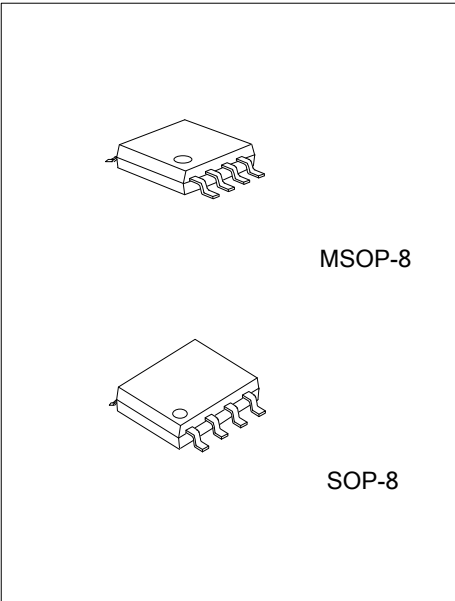
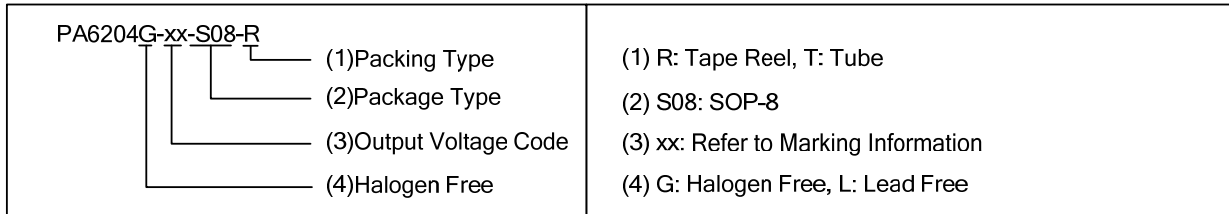

■ PIN CONFIGURATION

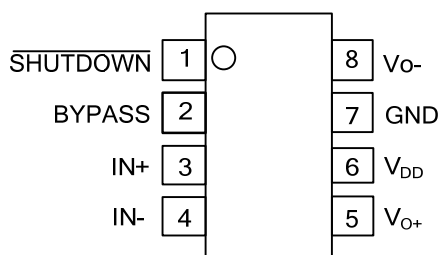

■ PIN DESCRIPTION

PIN NO.	PIN NAME	DESCRIPTION
1	SHUTDOWN	Shutdown Terminal (Active Low Logic)
2	BYPASS	Mid-supply Voltage, Adding a Bypass Capacitor Improves PSRR
3	IN+	Positive Differential Input
4	IN-	Negative Differential Input
5	Vo+	Positive BTL Output
6	V _{DD}	Power Supply
7	GND	High-current Ground
8	Vo-	Negative BTL Output

■ BLOCK DIAGRAM

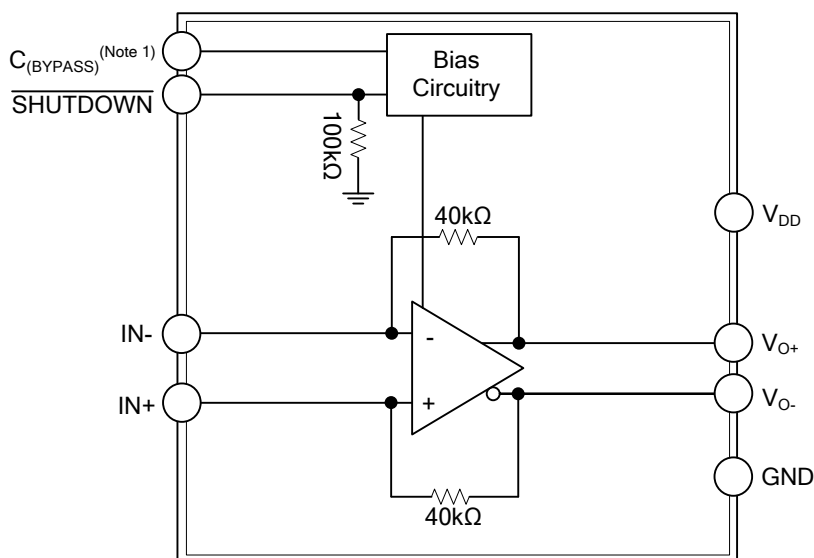

Note 1. C_(BYPASS) is optional.

■ **ABSOLUTE MAXIMUM RATING** (Over operating free-air temperature range unless otherwise noted)

PARAMETER	SYMBOL	RATINGS	UNIT
Supply Voltage	V_{DD}	-0.3~6	V
Input Voltage	V_I	-0.3~ $V_{DD}+0.3$	V
Power Dissipation($T_A=25^\circ\text{C}$)	P_D	0.5	W
Junction Temperature	T_J	-40~150	$^\circ\text{C}$
Operating Free-air Temperature	T_A	-40~85	$^\circ\text{C}$
Storage Temperature	T_{STG}	-65~150	$^\circ\text{C}$

Note: 1. Absolute maximum ratings are those values beyond which the device could be permanently damaged.

Absolute maximum ratings are stress ratings only and functional device operation is not implied.

2. Derating factor based on high-k board layout.

■ **RECOMMENDED OPERATING CONDITIONS**

PACKAGE	SYMBOL	MIN	TYP	MAX	UNIT
Supply Voltage	V_{DD}	2.5		5.5	V
High-level Input Voltage	SHUTDOWN V_{IH}	1.55			V
Low-level Input Voltage	SHUTDOWN V_{IL}			0.5	V
Operating Free-air Temperature	T_A	-40		85	$^\circ\text{C}$

■ **ELECTRICAL CHARACTERISTICS** ($T_A=25^\circ\text{C}$, unless otherwise specified)

PARAMETER	SYMBOL	TEST CONDITIONS	MIN	TYP	MAX	UNIT
Output Offset Voltage (Measured Differentially)	V_{OS}	$V_I=0\text{V}$ differential, Gain=1V/V, $V_{DD}=5.5\text{V}$	-9	0.3	9	mV
Power Supply Rejection Ratio	PSRR	$V_{DD}=2.5\text{V}\sim 5.5\text{V}$		-85	-60	dB
Common Mode Input Range	V_{IC}	$V_{DD}=2.5\text{V}\sim 5.5\text{V}$	0.5		$V_{DD}-0.8$	V
Common Mode Rejection Ratio	CMRR	$V_{DD}=5.5\text{V}$, $V_{IC}=0.5\text{V}\sim 4.7\text{V}$		-63	-40	dB
		$V_{DD}=2.5\text{V}$, $V_{IC}=0.5\text{V}\sim 1.7\text{V}$		-63	-40	
Low-Output Swing		$R_L=8\Omega$, Gain=1V/V $V_{IN+}=0\text{V}$, $V_{IN-}=V_{DD}$	$V_{DD}=5.5\text{V}$	0.45		V
			$V_{DD}=3.6\text{V}$	0.37		
			$V_{DD}=2.5\text{V}$	0.26	0.4	
High-Output Swing		$R_L=8\Omega$, Gain=1V/V $V_{IN+}=V_{DD}$, $V_{IN-}=0\text{V}$	$V_{DD}=5.5\text{V}$	4.95		V
			$V_{DD}=3.6\text{V}$	3.18		
			$V_{DD}=2.5\text{V}$	2	2.13	
High-Level Input Current, SHUTDOWN	$ I_{IH} $	$V_{DD}=5.5\text{V}$, $V_I=5.8\text{V}$		58	100	μA
Low-Level Input Current, SHUTDOWN	$ I_{IL} $	$V_{DD}=5.5\text{V}$, $V_I=-0.3\text{V}$		3	100	μA
Quiescent Current	I_Q	$V_{DD}=2.5\text{V}\sim 5.5\text{V}$, No Load		4	6	mA
Supply Current	$I_{(SD)}$	$V_{I(\text{SHUTDOWN})}\leq 0.5\text{V}$, $V_{DD}=2.5\text{V}\sim 5.5\text{V}$, $R_L=8\Omega$		0.01	1	μA
Gain		$R_L=8\Omega$	$\frac{38\text{k}\Omega}{R_I}$	$\frac{40\text{k}\Omega}{R_I}$	$\frac{42\text{k}\Omega}{R_I}$	V/V
Resistance From Shutdown To GND				100		k Ω

■ OPERATING CHARACTERISTICS (T_A=25°C, Gain=1V/V, unless otherwise specified)

PARAMETER	SYMBOL	TEST CONDITIONS	MIN	TYP	MAX	UNIT	
Output Power	P _O	THD+N=1%, f=1kHz, R _L =8Ω	V _{DD} =5V		1.36		W
			V _{DD} =3.6V		0.72		
			V _{DD} =2.5V		0.33		
		THD+N=10%, f=1kHz, R _L =8Ω	V _{DD} =5V		1.7		W
			V _{DD} =3.6V		0.85		
			V _{DD} =2.5V		0.4		
Total Harmonic Distortion Plus Noise	THD+N	V _{DD} =5V, P _O =1W, R _L =8Ω, f=1kHz		0.02		%	
		V _{DD} =3.6V, P _O =0.5W, R _L =8Ω, f=1kHz		0.02			
		V _{DD} =2.5V, P _O =200mW, R _L =8Ω, f=1kHz		0.03			
Supply Ripple Rejection Ratio	K _{SVR}	V _{DD} =3.6V, Inputs Ac-grounded With C _I =2μF, V _(RIPPLE) =200mV _{DD}	f=217Hz		-80	dB	
			f=20Hz~20kHz		-70		
Signal-To-Noise Ratio	SNR	V _{DD} =5V, P _O =1W, R _L =8Ω		105		dB	
Output Voltage Noise	V _N	V _{DD} =3.6V, f=20Hz~20kHz, Inputs Ac-grounded With C _I =2μF	No Weighting		15	μV _{RMS}	
			A Weighting		12		
Common Mode Rejection Ratio	CMRR	V _{DD} =3.6V, V _{IC} =1V _{PP}	f=217Hz		-65	dB	
Feedback Resistance	R _F		38	40	44	kΩ	
Start-up Time From Shutdown		V _{DD} =3.6V, C _{BYPASS} =0.1μF		27		ms	

■ TYPICAL APPLICATION CIRCUIT

Table 1. Typical Component Values

COMPONENT	VALUE	UNIT
R_I	40	k Ω
$C_{(BYPASS)}$ (Note 1)	0.22	μ F
C_S	1	μ F
C_I	0.22	μ F

Note: 1. $C_{(BYPASS)}$ is optional

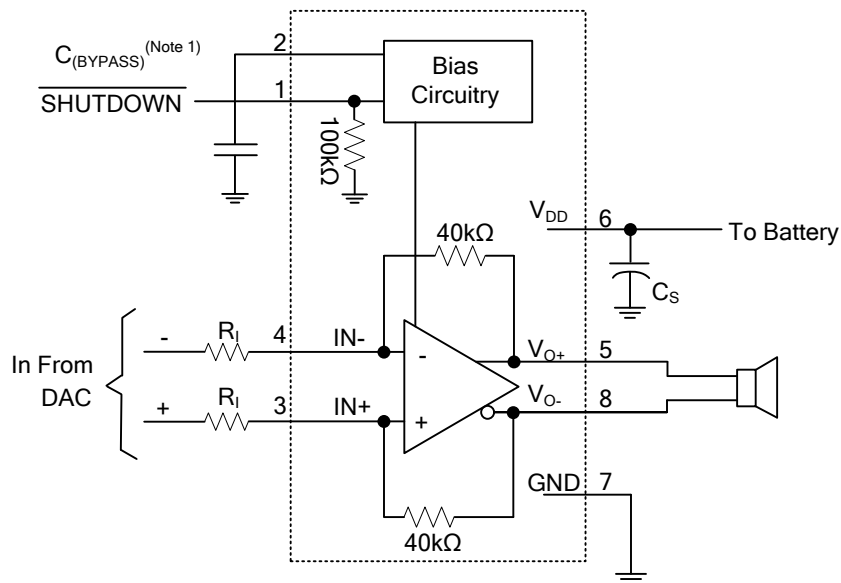

Note 1. $C_{(BYPASS)}$ is optional.

Figure 1. Typical Differential Input Application Schematic

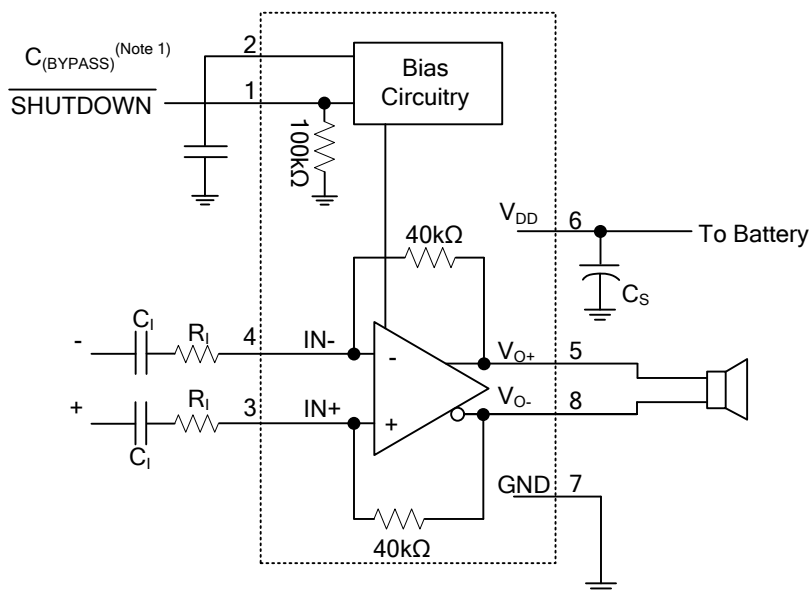

Note 1. $C_{(BYPASS)}$ is optional.

Figure 2. Differential Input Application Schematic Optimized With Input Capacitors

■ TYPICAL APPLICATION CIRCUIT(Cont.)

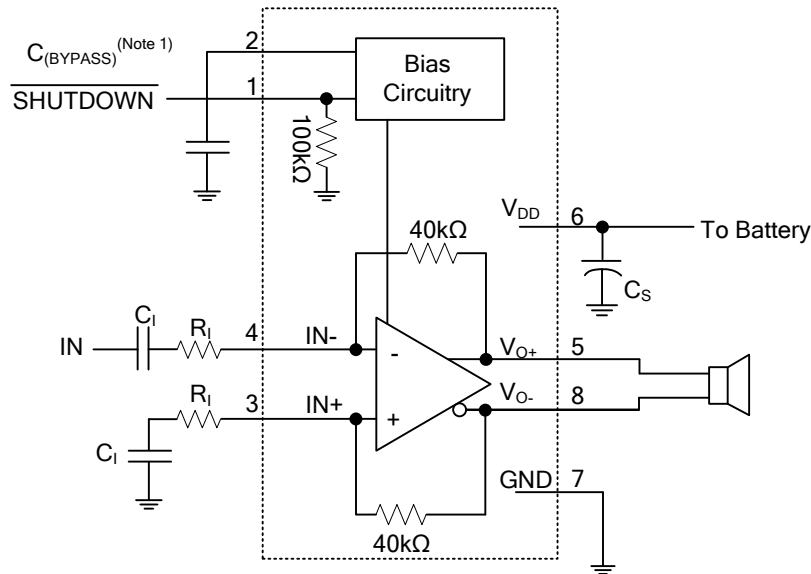

Note 1. $C_{(BYPASS)}$ is optional.

Figure 3. Single-Ended Input Application Schematic

UTC assumes no responsibility for equipment failures that result from using products at values that exceed, even momentarily, rated values (such as maximum ratings, operating condition ranges, or other parameters) listed in products specifications of any and all UTC products described or contained herein. UTC products are not designed for use in life support appliances, devices or systems where malfunction of these products can be reasonably expected to result in personal injury. Reproduction in whole or in part is prohibited without the prior written consent of the copyright owner. The information presented in this document does not form part of any quotation or contract, is believed to be accurate and reliable and may be changed without notice.