



UM2640

Preliminary

CMOS IC

TWO-PHASE UNIPOLAR DC BRUSHLESS MOTOR PRE-DRIVER IC

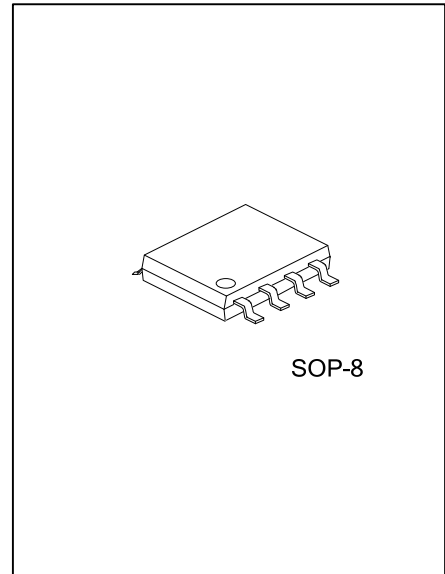

DESCRIPTION

UTC UM2640 is a 2-phase pre-driver IC for unipolar DC brushes motors. It features high voltage bipolar technology so that the driver works up to 48V. High voltage operation delivers more power and improves power supply efficiency. Therefore, it is suitable for high voltage fan motor applications.

FEATURES

- * Wide supply voltage range of 4V~55V
* Absolute Maximum Voltage 60V
* Lock protection.
Auto-restart when the motor lock is undone.
* Lock Alarm Output Terminal

ORDERING INFORMATION

Table with 4 columns: Ordering Number (Lead Free, Halogen Free), Package, Packing. Rows include UM2640L-SO8-R, UM2640G-SO8-R, UM2640L-SO8-T, UM2640G-SO8-T.

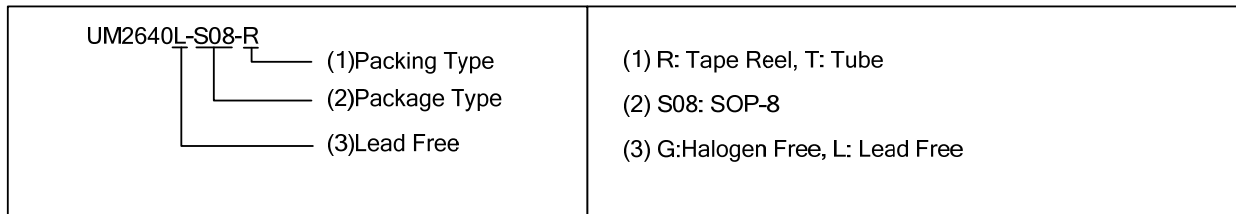

■ PIN CONFIGURATION

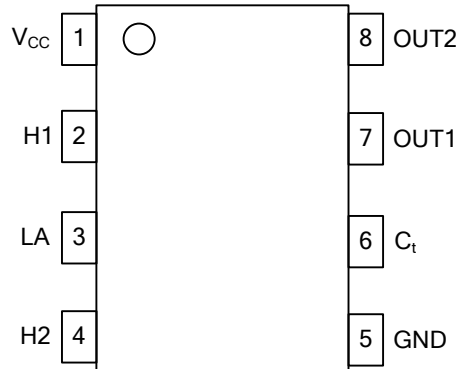

■ PIN DESCRIPTION

PIN NO.	PIN NAME	DESCRIPTION
1	V _{CC}	Supply voltage
2	H1	Positive input for hall amplifier
3	LA	Lock alarm output
4	H2	Negative input for hall amplifier
5	GND	Ground
6	C _t	Timing capacitance
7	OUT1	Output voltage
8	OUT2	Output voltage

■ BLOCK DIAGRAM

2 Phase Fan Motor
PRE-DRIVER

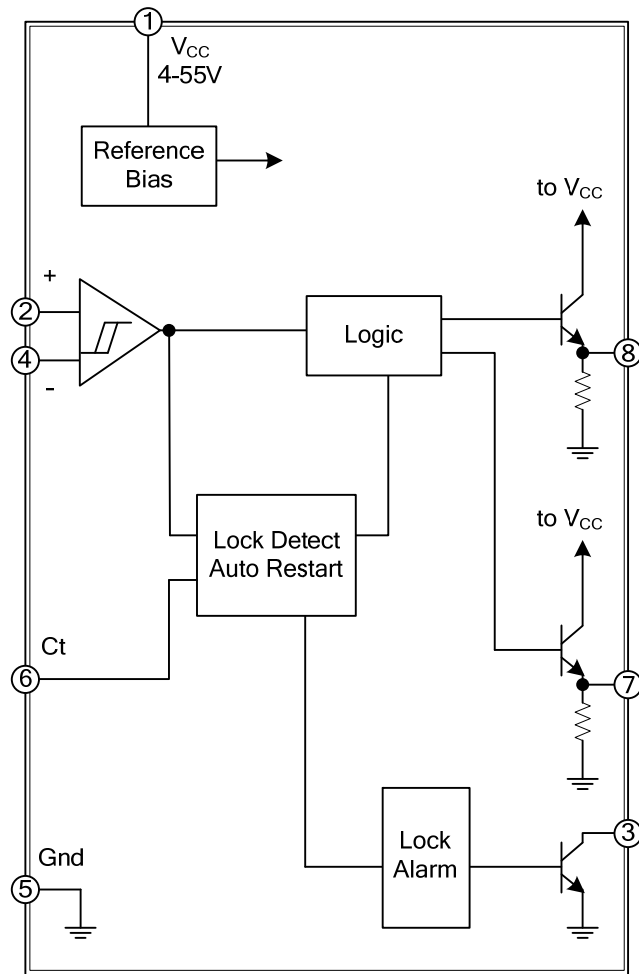

■ ABSOLUTE MAXIMUM RATING (T_A=25°C)

PARAMETER	SYMBOL	RATINGS	UNIT
Supply Voltage	V _{CC}	60	V
Hall Input Voltage Range	V _{IH}	-0.3~V _{CC}	V
Output Current	I _{OUT}	30	mA
Lock Alarm Output Voltage	V _{OLA}	60	V
Hall Input Differential Voltage	V _{IHD}	2	V
Lock Alarm Output Current	I _{OLA}	20	mA
Power Dissipation	P _D	375	mW
Operating Temperature	T _{OPR}	-40~85	°C
Storage Temperature	T _{STG}	-55~150	°C

Note: Absolute maximum ratings are those values beyond which the device could be permanently damaged.
Absolute maximum ratings are stress ratings only and functional device operation is not implied.

■ ELECTRICAL CHARACTERISTICS (V_{CC}=48V, T_A = 25°C)

PARAMETER	SYMBOL	TEST CONDITIONS	MIN	TYP	MAX	UNIT
Operating Supply Voltage Range	V _{CC}		4.0	48.0	55.0	V
Operating Current	I _{CC}	V _{CC} =24V		3.0	4.0	mA
		V _{CC} =48V		3.8	4.8	
Hall Input Hysteresis Range	V _{HYS}		8	20	32	mV
Hall Amplifier Input Bias Current	I _B			0.5	1.0	μA
Hall Input Common Mode Voltage	V _{ICM}		1.5		V _{CC} -2	V
Output Voltage	V _{OUT}	I _{OUT} =10mA		V _{CC} -1.5		V
Output Leak Current	I _{LEAK}	V _{CC} =60V			5	μA
Lock Alarm Output Voltage	V _{LA}	Lock Alarm ON, I _{LA} =5mA			0.5	V
Lock Alarm Leak Current	I _{LA-LEAK}	V _{LA} =60V			10	μA
Ct Charge Current	I _{CHG}	V _{CI} =1.5V		3.8		μA
Ct Discharge Current	I _{DCHG}	V _{CI} =1.5V		0.75		μA
Charge/Discharge Current Ratio	I _{CHG} /I _{DCHG}		4.0	5.5	8.0	
Ct H Level Cense Voltage	V _{CH}		2.2	2.5	2.8	V
Ct L Level Cense Voltage	V _{CL}		0.6	0.7	0.8	V
Auto Protection Release ON Time	T _{ON}	C _T =0.47μF		0.25		s
Auto Protection Release OFF Time	T _{OFF}	C _T =0.47μF		1.25		s

■ APPLICATION INFORMATION

The UTC **UM2640** is a two-phase unipolar DC brushes motor pre-driver IC that features high voltage process technology so that the driver works up to 60V.

It is suitable for high voltage fan motor applications where 48V operation is required.

[example of application circuit]

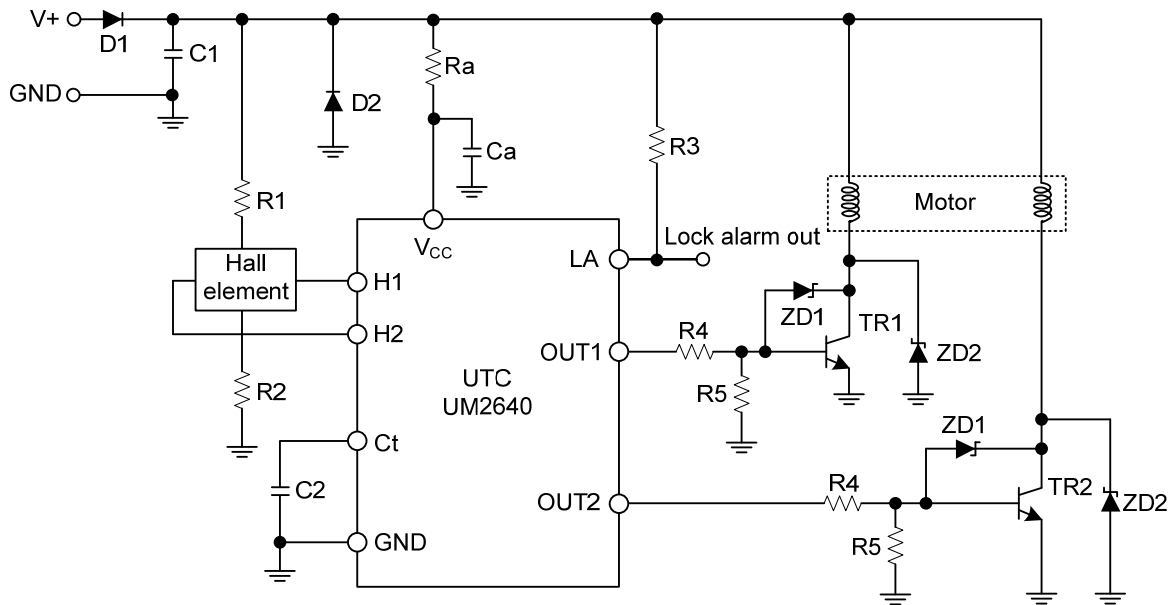

[Design Notes]

Above application example is designed for 48V operation with motor current of 300mA. It uses the following components:

Hall Elements: HW101A (AKD)

TR1, TR2: 2SC4027A (UTC)

1. Design of R4 and R5

$$R4 = \frac{V_{CC} - V_{BE} - V_{CE}}{I_B}$$

Where; V_{CC} is 48V, V_{CE} of UTC **UM2640** is 1.5V, V_{BE} of TR1 is 0.7V. I_B is the base current of TR1.

The pull down resistance R5 (connected to TR1) influences turn-off time of TR1.

A typical R5 value is ranging from 1kΩ to 10kΩ. It is highly recommended to determine the value with actual application for better noise performance.

■ APPLICATION INFORMATION(Cont.)

2. Design of Ra and Ca

Ra and Ca must be used if V_{CC} exceeds operating voltage range of UTC **UM2640**.

Example of V_{CC} 60V Application

Given that current consumption of UTC **UM2640** is 4mA (at $V_{CC}=48V$), Ra is given by:

$$R_a = \frac{60 - 48}{4 \times 10^{-3}} = 3k\Omega$$

Ca is needed if UTC **UM2640** is oscillated or shows unstable operation. A typical value of Ca is from 0.01 μ F to 0.1 μ F. A ceramic type is recommended and it must be placed near V_{CC} and Gnd.

By insertion of Ra and Ca, the ESD immunity is improved greatly.

3. Design of D2

If an application requires active power on and off, TR1 (TR2) may be damaged or resulted in destruction.

In such application, adding diode between motor winding and Gnd will reduce the damage.

4. Design of ZD1 and ZD2

Zenner diodes are used for limiting kick back voltage of motor winding generated when power transistors is (TR1 and TR2) turned off from on.

There are two methods to consume kick back voltage:

1) Inserting ZD1 (zenner diode connected between Base and Collector of TR1) Energy of kick back voltage is consumed by TR1 (or TR2). When ZD1 is in operation, Collector voltage is sum of V_{be} and ZD1. Therefore, breakdown voltage of ZD1 must be lower than that of TR1.

2) Inserting ZD2 (zenner diode connected between Collector and Emitter of TR1) Energy of kick back voltage is consumed by ZD2. To protect TR1, breakdown voltage of ZD2 must be lower than that of TR1.

This method is generally used when Energy of kick back voltage is large. In such application, power rating of ZD must take in consideration.

5. Selection of C1 and D1:

C1 is used to weaken noise. A typical value is 0.1 μ F.

Optimize the value in actual operating conditions if necessary. D1 is a diode for protecting against reverse voltage supply. Silicon rectifier diode is appropriate.

6. Design of R1 and R2

Hall amplifier is a differential amplifier with hysteresis characteristics (24mV typical).

The common-mode input voltage is between 1.5V and $V_{CC}-2V$ and the input signal must be within the range.

Non-excitation hall bias voltage is to be set at a half of V_{CC} for effective use of common-mode input voltage range. Therefore the same value of hall bias resistors is selected for R1 and R2.

The output voltage of hall elements is effected by the bias current and magnetic flux density of hall elements.

The optimum input voltage of UTC **UM2640** is 100mVp-p and higher. With such input voltage, the highest efficiency can be obtained.

■ APPLICATION INFORMATION(Cont.)

7. Design of C2:

Lock Protection Function, consists of Motor Lock Detection and Auto Resume Function, is a safety feature to protect a motor and a driver circuit from fatal destruction in case of motor halt.

Motor Lock Detection detects motor halt due to irregular load conditions and then cuts motor driving current for safety operation. When Lock Detection is activated; Lock Alert Out (LA: Pin 3) goes to L.

A value of C2 determines Lock detection time (Ton) and Auto Resume Time (Toff).

Lock detection time (Ton) is given by:

$$T_{ON} = C2 \frac{V_{ch} - V_{cl}}{I_c} [\text{sec}]$$

Where C2 is 0.47uF:

$$T_{ON} = 0.47 \times 10^{-6} \times \frac{2.5 - 0.7}{3.8 \times 10^{-6}} = 0.22[\text{sec}]$$

Auto Resume Time (Toff) is given by:

$$T_{OFF} = C2 \frac{V_{ch} - V_{cl}}{I_{dc}} [\text{sec}]$$

Where C2 is 0.47uF:

$$T_{OFF} = 0.47 \times 10^{-6} \times \frac{2.5 - 0.7}{0.75 \times 10^{-6}} = 1.13[\text{sec}]$$

A typical value of C2 is either 0.47uF or 1uF depending on a motor.

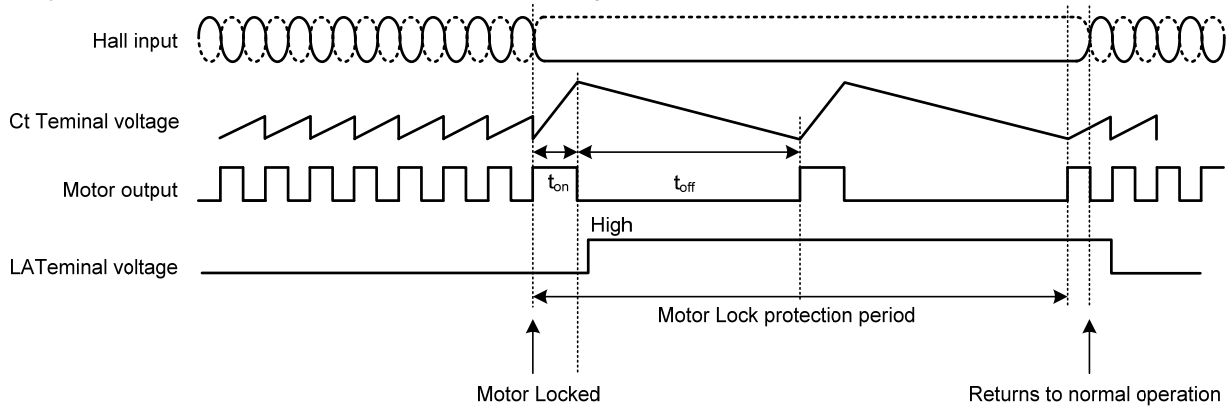

Lock Protection

Lock Alert Out (LA: Pin 3) is an open collector output and R3 is a pull up resistor. A typical value of R3 is 10kΩ.

It must be noted that Lock Alert Out stays an H state during few hundred milliseconds from power up as shown in the picture below.

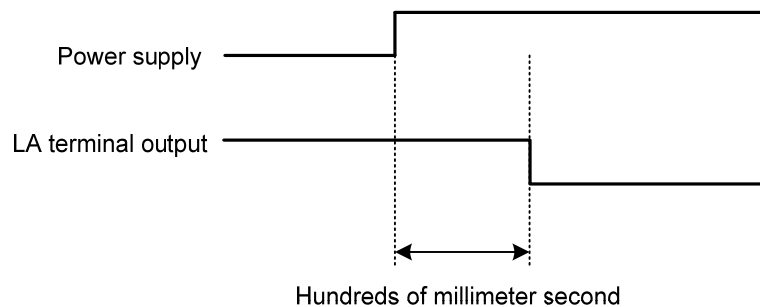

UTC assumes no responsibility for equipment failures that result from using products at values that exceed, even momentarily, rated values (such as maximum ratings, operating condition ranges, or other parameters) listed in products specifications of any and all UTC products described or contained herein. UTC products are not designed for use in life support appliances, devices or systems where malfunction of these products can be reasonably expected to result in personal injury. Reproduction in whole or in part is prohibited without the prior written consent of the copyright owner. The information presented in this document does not form part of any quotation or contract, is believed to be accurate and reliable and may be changed without notice.