



# TDA2005

## LINEAR INTEGRATED CIRCUIT

### 20W BRIDGE AMPLIFIER FOR CAR RADIO

#### DESCRIPTION

The UTC TDA2005 is class B dual audio power amplifier, have designed for car radio application.

#### FEATURES

\* High output power:

$P_{OUT}=10+10W@R_L=2\Omega$ , THD=10%

$P_{OUT}=20W@R_L=4\Omega$ , THD=1%

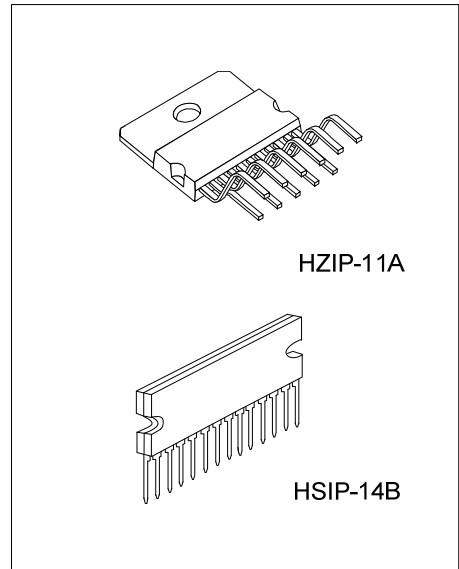

#### ORDERING INFORMATION

Ordering Number		Package	Packing
Lead Free	Halogen Free		
TDA2005L-J11-A-T	TDA2005G-J11-A-T	HZIP-11A	Tube
TDA2005L-H14-B-T	TDA2005G-H14-B-T	HSIP-14B	Tube

<p>TDA2005L-J11-A-T</p> <p>(1) Packing Type (2) Package Type (3) Lead Free</p>	<p>(1) T: Tube (2) J11-A: HZIP-11A, H14-B: HSIP-14B (3) G: Halogen Free, L: Lead Free</p>
--	---

## ■ PIN CONFIGURATION

HZIP-11A

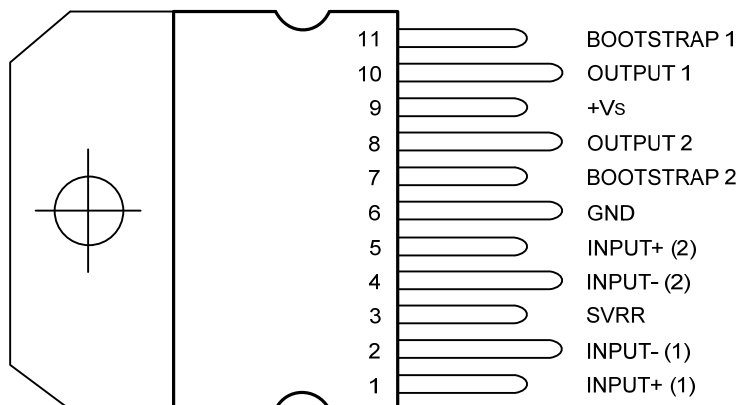

\*TAB CONNECTED TO PIN 6

HSIP-14B

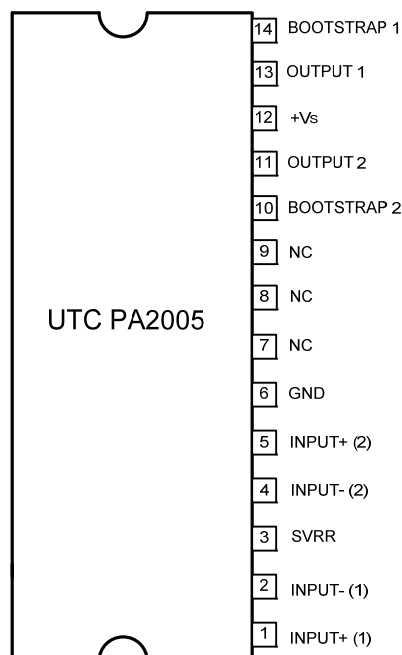

## ■ PIN DESCRIPTION

PIN NO.		PIN NAME
HZIP-11	HSIP-14*	
1	1	INPUT+ (1)
2	2	INPUT- (1)
3	3	SVRR
4	4	INPUT- (2)
5	5	INPUT+ (2)
6	6	GND
7	10	BOOTSTRAP 2
8	11	OUTPUT 2
9	12	+Vs
10	13	OUTPUT 1
11	14	BOOTSTRAP 1

\* PIN 7, 8, 9 no connection.

## ■ BLOCK DIAGRAM

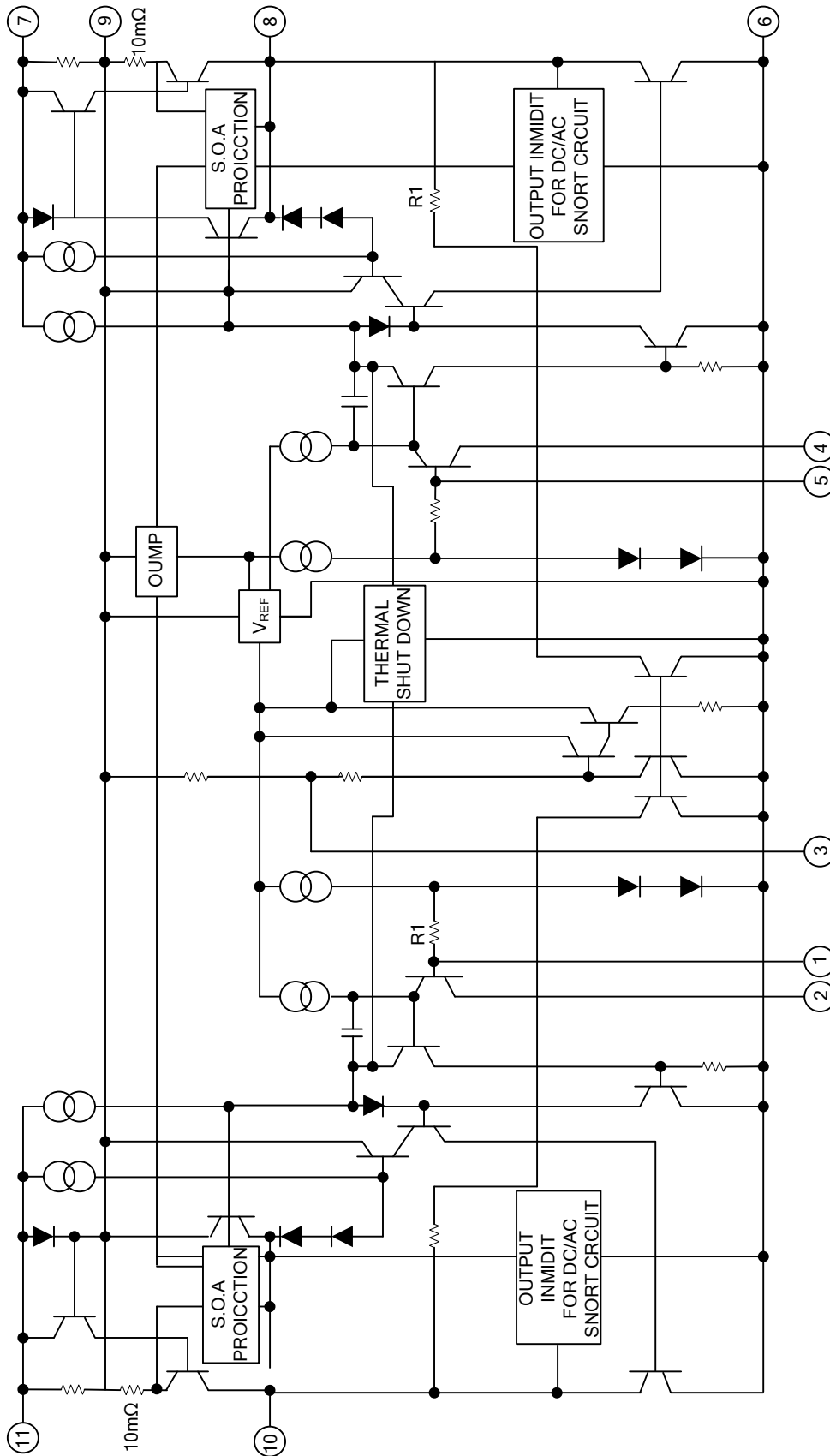

## ■ ABSOLUTE MAXIMUM RATINGS

PARAMETER	SYMBOL	RATINGS	UNIT	
Operating Supply Voltage	$V_{SS}$	18	V	
DC Supply Voltage	$V_{SS}$	28	V	
Peak Supply Voltage (for 50ms)	$V_{SS}$	40	V	
Output Peak Current (Note)	non repetitive $t=0.1ms$	$I_o$	4.5	A
	repetitive $f \geq 10Hz$	$I_o$	3.5	A
Power Dissipation at $T_C=60^\circ C$	$P_D$	30	W	
Junction Temperature	$T_J$	+150	$^\circ C$	
Storage Temperature	$T_{STG}$	-40 ~ 150	$^\circ C$	

Note: The max. output current is internally limited.

## ■ THERMAL DATA

PARAMETER	SYMBOL	RATINGS	UNIT
Junction to Case	$\theta_{JC}$	3.0	$^\circ C/W$

## ■ ELECTRICAL CHARACTERISTICS

(Refer to the application circuit,  $T_A=25^\circ C$ ,  $G_V=50dB$ ,  $R_{TH}(\text{heatsink})=4^\circ C/W$ , unless otherwise specified.)

PARAMETER	SYMBOL	TEST CONDITIONS	MIN	TYP	MAX	UNIT
<b>BRIDGE</b>						
Supply Voltage	$V_{SS}$		8		18	V
Output Offset Voltage (between pin 8 and pin 10)	$V_{OS}$	$V_{SS}=14.4V$			150	mV
		$V_{SS}=13.2V$			150	
Total Quiescent Drain Current	$I_D$	$V_{SS}=14.4V, R_L=4\Omega$		75	150	mA
		$V_{SS}=13.2V, R_L=3.2\Omega$		70	160	
Output Power	$P_{OUT}$	THD=10%, $f=1Hz$	$V_{SS}=14.4V, R_L=4\Omega$	18	20	W
			$R_L=3.2\Omega$	20	22	
			$V_{SS}=13.2V, R_L=3.2\Omega$	17	19	
Total Harmonic Distortion $f=1KHz$	THD	$V_{SS}=14.4V, R_L=4\Omega$ , $P_{OUT}=50mW \sim 15W$			1	%
		$V_{SS}=13.2V, R_L=3.2\Omega$ , $P_{OUT}=50mW \sim 13W$			1	%
Input Sensitivity $f=1kHz$	$V_{IN}$	$P_{OUT}=2W, R_L=4\Omega$		9		mV
		$P_{OUT}=2W, R_L=3.2\Omega$		8		mV
Input Resistance	$R_{IN}$	$f=1kHz$	70			k $\Omega$
Low Frequency Roll Off (-3dB)	$f_L$	$R_L=3.2\Omega$			40	Hz
High Frequency Roll Off (-3dB)	$f_H$	$R_L=3.2\Omega$	20			kHz
Closed Loop Voltage Gain	$G_V$	$f=1kHz$		50		dB
Total Input Noise Voltage	$e_N$	$R_G=10k\Omega$ (Note 1)		3	10	$\mu V$
Supply Voltage Rejection	SVR	$R_G=10k\Omega, C_4=10\mu F$ $F_{RIPPLE}=100Hz, V_{RIPPLE}=0.5V$	45	55		dB
Efficiency	$\eta$	$V_{SS}=14.4V, f=1kHz$	$P_{OUT}=20W, R_L=4\Omega$		60	%
			$P_{OUT}=22W, R_L=3.2\Omega$		60	
		$V_{SS}=13.2V, f=1kHz$	$P_{OUT}=19W, R_L=3.2\Omega$		58	%
Thermal Shut-down Junction Temperature	$T_J$	$V_{SS}=14.4V, R_L=4\Omega$ , $f=1kHz, P_D=13W$		145		$^\circ C$
Output Voltage With One Side of the Speaker Shorted to Ground	$V_{OSH}$	$V_{SS}=14.4V, R_L=4\Omega$				V
		$V_{SS}=13.2V, R_L=3.2\Omega$			2	

## ■ ELECTRICAL CHARACTERISTICS(Cont.)

PARAMETER	SYMBOL	TEST CONDITIONS	MIN	TYP	MAX	UNIT
<b>STEREO</b>						
Supply Voltage	$V_{SS}$		8		18	V
Quiescent Output Voltage	$V_{OUT}$	$V_{SS}=14.4V$	6.6	7.2	7.8	V
		$V_{SS}=13.2V$	6	6.6	7.2	
Total Quiescent Drain Current	$I_D$	$V_{SS}=14.4V$		65	120	mA
		$V_{SS}=13.2V$		62	120	
Output Power (each channel) f=1Hz, THD=10%	$P_{OUT}$	$V_{SS}=14.4V$	$R_L=4\Omega$	6	6.5	W
			$R_L=3.2\Omega$	7	8	
			$R_L=2\Omega$	9	10	
		$V_{SS}=13.2V$	$R_L=3.2\Omega$	6	6.5	
			$R_L=1.6\Omega$	9	10	
		$V_{SS}=16V, R_L=2\Omega$			12	
Total Harmonic Distortion (each channel) f=1KHz	THD	$V_{SS}=14.4V, R_L=4\Omega,$ $P_{OUT}=50mW \sim 4W$		0.2	1	%
		$V_{SS}=14.4V, R_L=2\Omega,$ $P_{OUT}=50mW \sim 6W$		0.3	1	%
		$V_{SS}=13.2V, R_L=3.2\Omega,$ $P_{OUT}=50mW \sim 3W$		0.2	1	%
		$V_{SS}=13.2V, R_L=1.6\Omega,$ $P_{OUT}=40mW \sim 6W$		0.3	1	%
Cross Talk	$C_T$	$V_{SS}=14.4V, R_G=5K\Omega, V_{OUT}=4V_{RMS}, R_L=4\Omega$	f=1KHz		60	dB
			f=10kHz		45	
Input Saturation Voltage	$V_{IN}$		300			mV
Input Sensitivity	$V_{IN}$	f=1kHz, $P_{OUT}=1W$ $R_L=4\Omega$ $R_L=3.2\Omega$		6 5.5		mV
Input Resistance	$R_{IN}$	f=1kHz	70	200		k $\Omega$
Low Frequency Roll Off (-3dB)	$f_L$	$R_L=2\Omega$			50	Hz
High Frequency Roll Off (-3dB)	$f_H$	$R_L=2\Omega$	15			kHz
Voltage Gain (open loop)	$G_V$	f=1kHz		90		dB
Voltage Gain (close loop)	$G_V$	f=1kHz	48	50	51	dB
Closed Loop Gain Matching	$\Delta G_V$			0.5		dB
Total Input Noise Voltage	$E_n$	$R_G=10k\Omega$ (Note 1)		1.5	5	$\mu V$
Supply Voltage Rejection	SVR	$R_G=10k\Omega, C_3=10\mu F,$ $F_{RIPPLE}=100Hz, V_{RIPPLE}=0.5V$	35	45		dB
Efficiency	$\eta$	$V_{SS}=14.4V,$ f=1kHz	$P_{OUT}=6.5W, R_L=4\Omega$ $P_{OUT}=10W, R_L=2\Omega$	70 60		%
		$V_{SS}=13.2V,$ f=1kHz	$P_{OUT}=6.5W, R_L=3.2\Omega$ $P_{OUT}=10W, R_L=1.6\Omega$	70 60		

Note: 1. Bandwith Filter: 22Hz ~ 22kHz

## TEST AND APPLICATION CIRCUIT

### Bridge amplifier

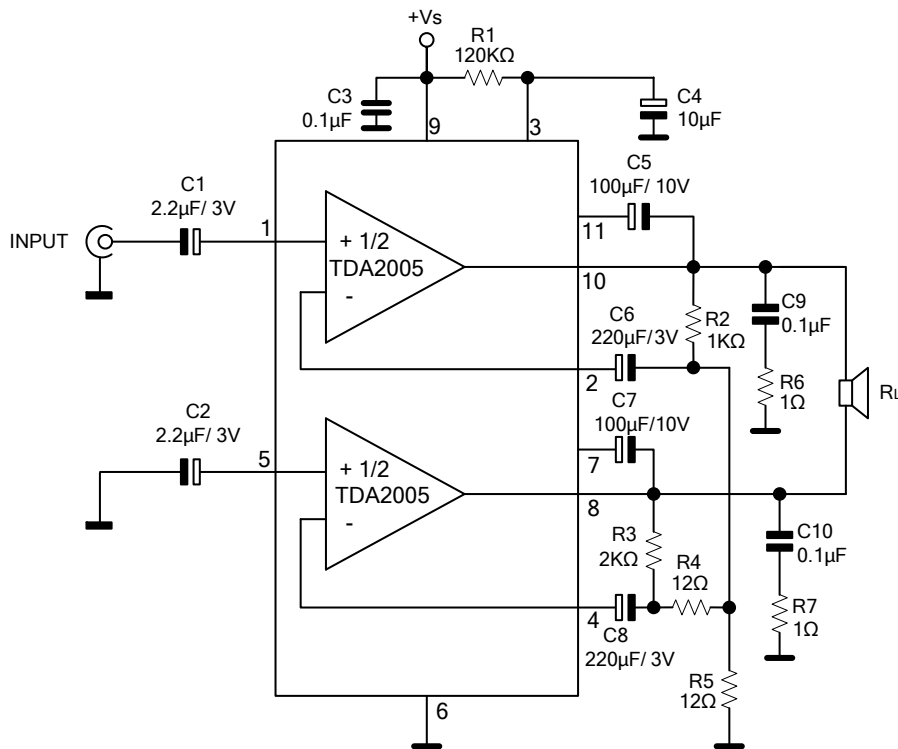

### Stereo amplifier

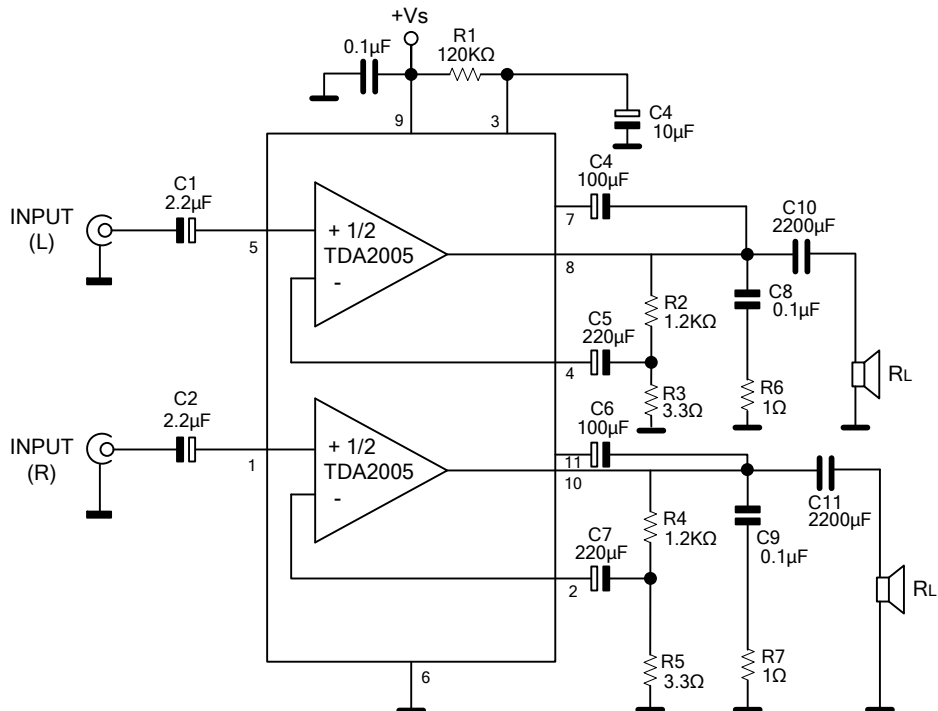

## BRIDGE AMPLIFIER DESIGN

The following considerations can be useful when designing a bridge amplifier.

PARAMETER		SINGLE ENDED	BRIDGE
V <sub>OUT</sub> max	Peak Output Voltage (before clipping)	$\frac{1}{2} (V_S - 2V_{CE\ sat})$	$V_S - 2V_{CE\ sat}$
I <sub>OUT</sub> max	Peak Output Current (before clipping)	$\frac{1}{2} \frac{V_S - 2V_{CE\ sat}}{R_L}$	$\frac{V_S - 2V_{CE\ sat}}{R_L}$
P <sub>OUT</sub> max	RMS Output Power (before clipping)	$\frac{1}{4} \frac{(V_S - 2V_{CE\ sat})^2}{2R_L}$	$\frac{(V_S - 2V_{CE\ sat})^2}{2R_L}$

Where: V<sub>CE sat</sub>=output transistors saturation voltage

V<sub>S</sub>=allowable supply voltage

R<sub>L</sub>=load impedance

Voltage and current swings are twice for a bridge amplifier in comparison with single ended amplifier. In other words, with the same R<sub>L</sub> the bridge configuration can deliver an output power that is four times the output power of a single ended amplifier, while, with the same max output current the bridge configuration can deliver an output power that is twice the output power of a single ended amplifier. Care must be taken when selecting V<sub>S</sub> and R<sub>L</sub> in order to avoid an output peak current above the absolute maximum rating.

From the expression for I<sub>o</sub> max, assuming V<sub>S</sub>=14.4V and V<sub>CE sat</sub>=2V, the minimum load that can be driven by UTC **TDA2005** in bridge configuration is:

$$R_{L\ min} = \frac{V_S - 2V_{CE\ sat}}{I_{OUT\ max}} = \frac{14.4 - 4}{3.5} = 2.97\Omega$$

The voltage gain of the bridge configuration is given by (see Figure 3):

$$G_V = \frac{V_0}{V_1} = 1 + \frac{R_1}{\left(\frac{R_2 \cdot R_4}{R_2 + R_4}\right)} + \frac{R_3}{R_4}$$

For sufficiently high gains (40 ~ 50dB) it is possible to put R<sub>2</sub>=R<sub>4</sub> and R<sub>3</sub>=2R<sub>1</sub>, simplifying the formula in:

$$G_V = 4 \frac{R_1}{R_2}$$

G <sub>V</sub> (dB)	R <sub>1</sub> (Ω)	R <sub>2</sub> =R <sub>4</sub> (Ω)	R <sub>3</sub> (Ω)
40	1000	39	2000
50	1000	12	2000

## Bridge Configuration

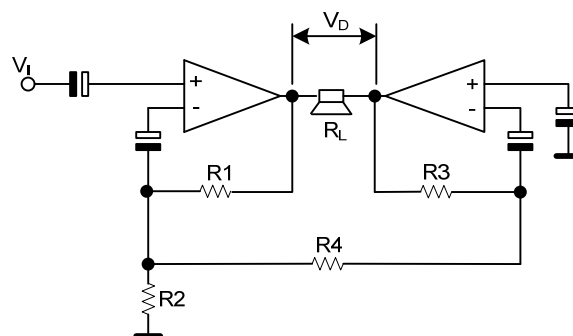



## APPLICATION INFORMATION(Cont.)

### 10+10W Stereo Amplifier with Tone Balance and Loudness Control

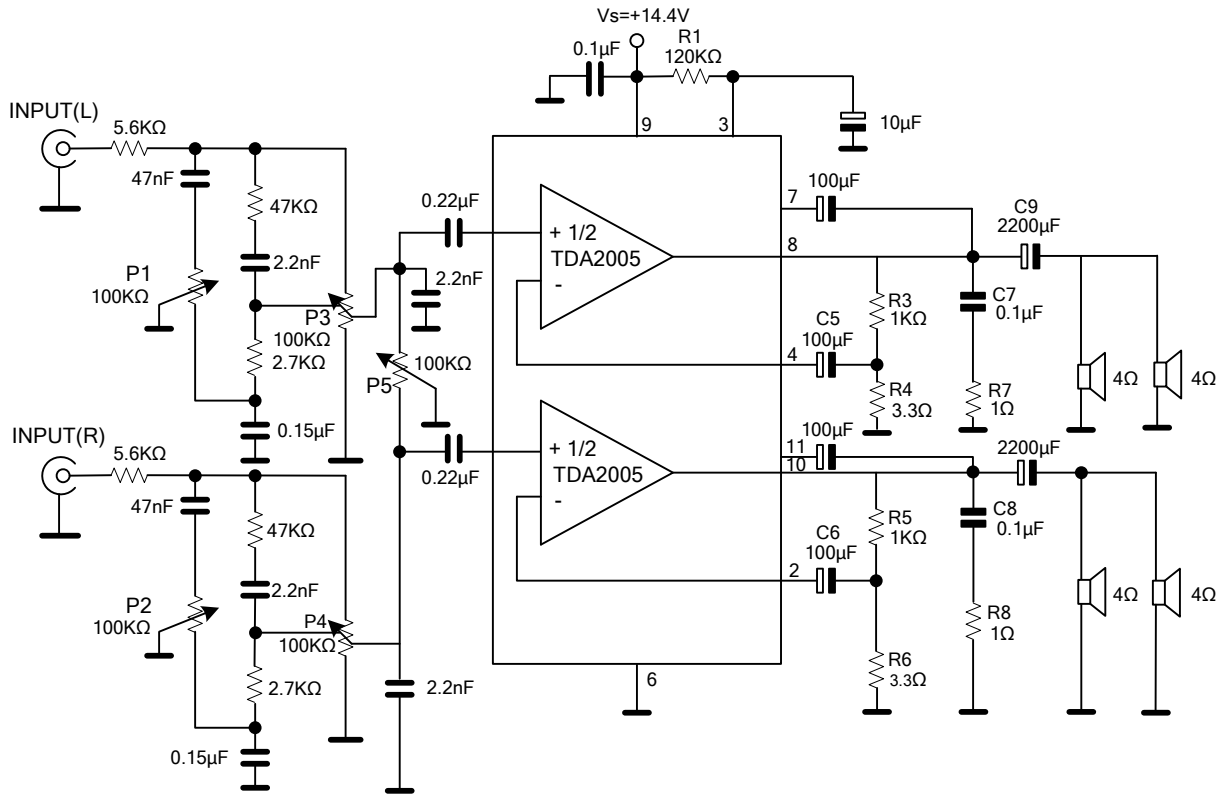

Tone Control Response (circuit of Fihure 8)

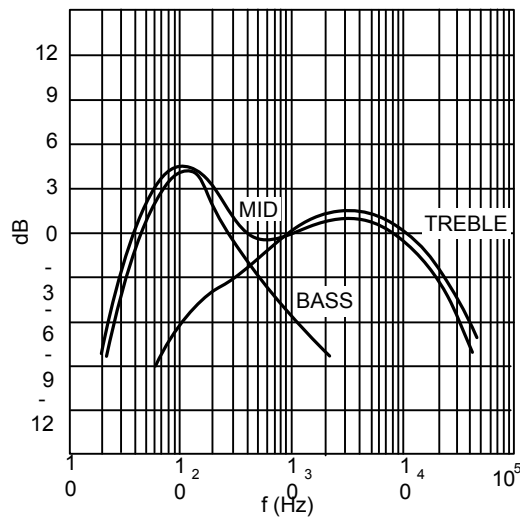

## ■ APPLICATION INFORMATION(Cont.)

### 20W Bus Amplifier

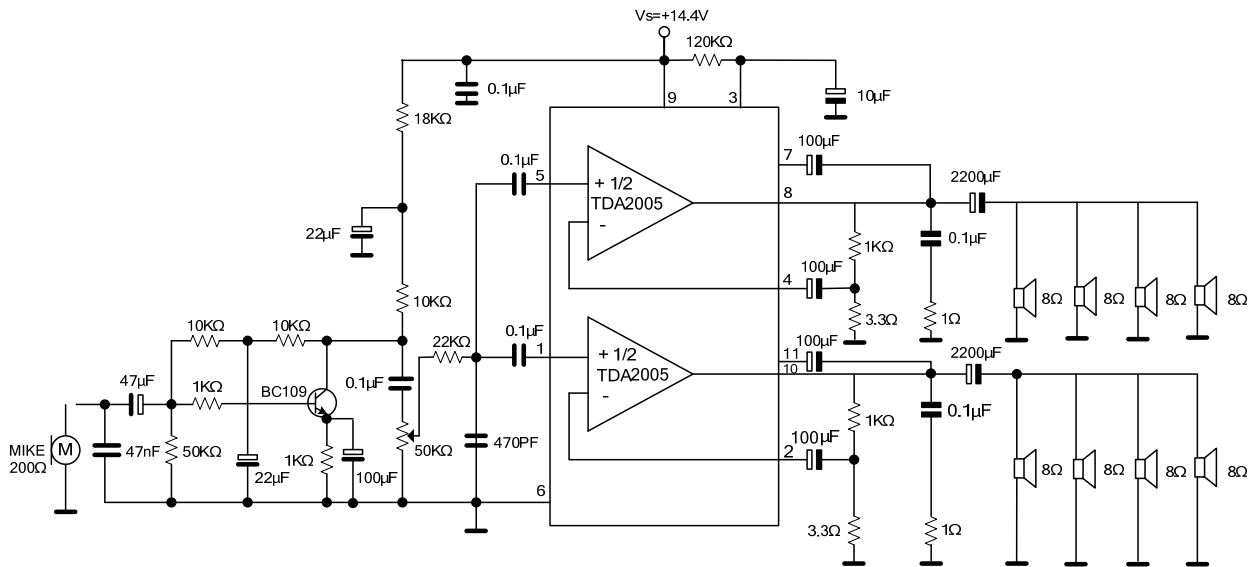

### Simple 20W Two Way Amplifier ( $F_c=2\text{kHz}$ )

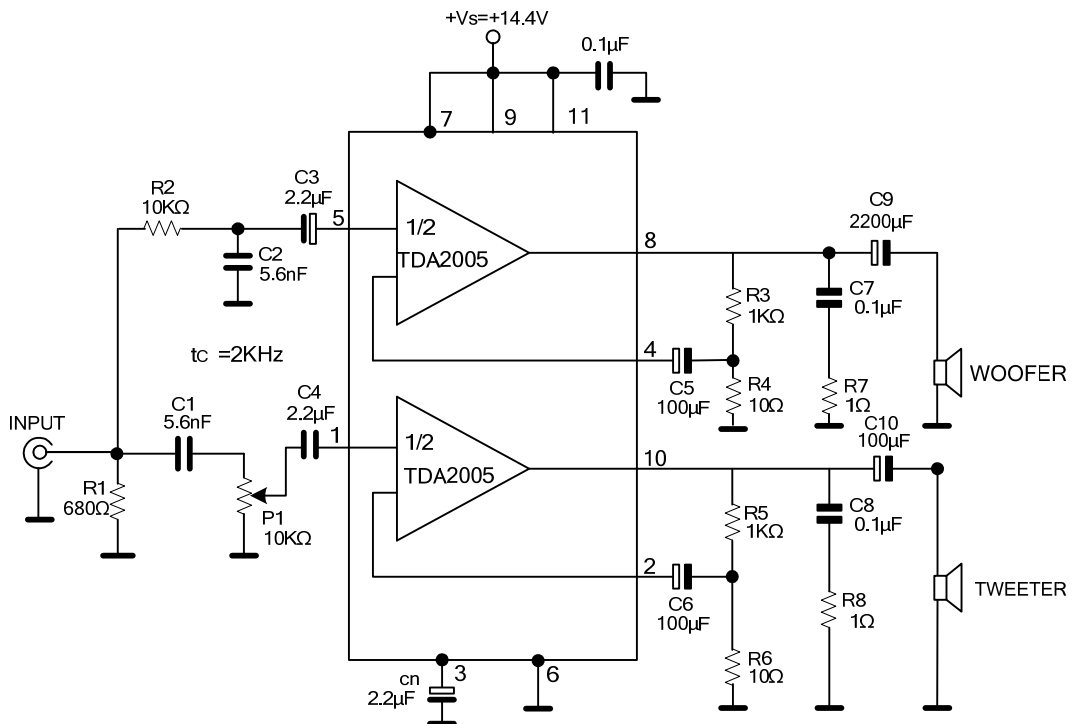

## ■ APPLICATION INFORMATION(Cont.)

### Bridge Amplifier Circuit suited for Low-gain Applications ( $G_V=34dB$ )

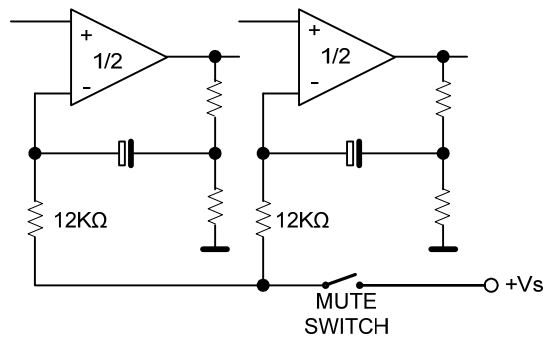
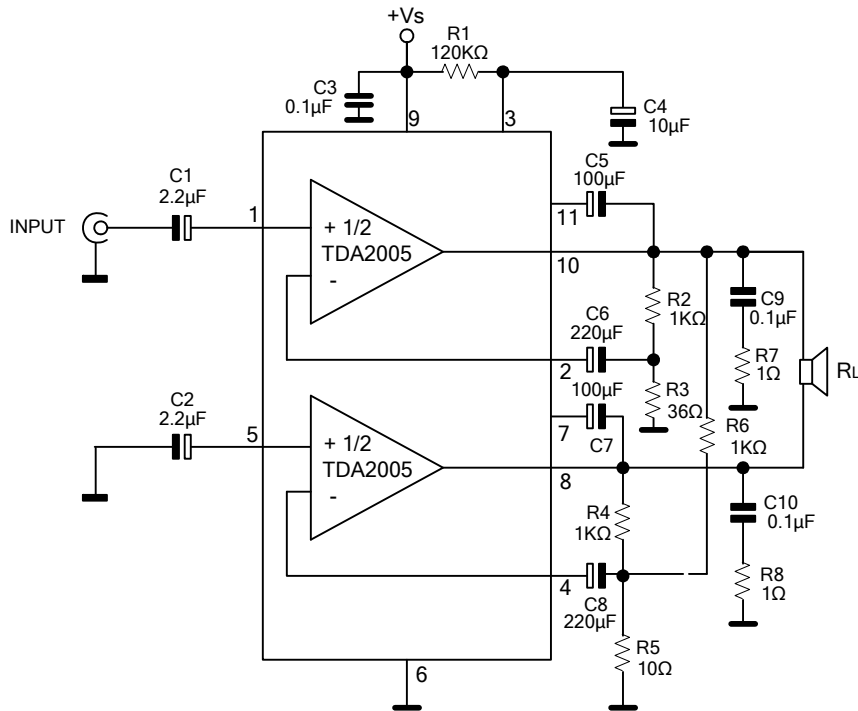

Fig. 1 Example of Muting Circuit

## ■ BUILT-IN PROTECTION SYSTEMS

### LOAD DUMP VOLTAGE SURGE

The UTC **TDA2005** has a circuit which enables it to withstand a voltage pulse train, on pin9, of the type shown in Figure 3.

If the supply voltage peaks to more than 40V, then an LC filter must be inserted between the supply and pin9, in order to assure that the pulses at pin 9 will be held within the limits shown.

A suggested LC network is shown in Figure 2. With this network, a train of pulses with amplitude up to 120V and width of 2ms can be applied at point A. This type of protection is ON when the supply voltage (pulse or DC) exceeds 18V. For this reason the maximum operating supply voltage is 18V.

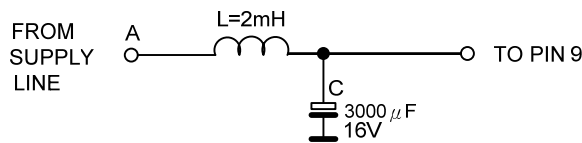

Fig. 2

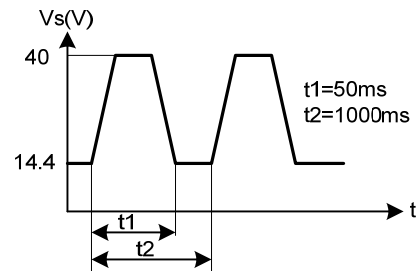

Fig. 3

### SHORT CIRCUIT (AC AND DC CONDITIONS)

The UTC **TDA2005** can withstand a permanent short circuit on the output for a supply voltage up to 16V.

### POLARITY INVERSION

High current (up to 10A) can be handled by the device with no damage for a longer period than the blow-out time of a quick 2A fuse (normally connected in series with the supply). This feature is added to avoid destruction, if during fitting to the car, a mistake on the connection of the supply is made.

### OPEN GROUND

When the ratio is in the ON condition and the ground is accidentally opened, a standard audio amplifier will be damaged. On the UTC **TDA2005** protection diodes are included to avoid any damage.

### INDUCTIVE LOAD

A protection diode is provided to allow use of the UTC **TDA2005** with inductive loads.

### DC VOLTAGE

The maximum operating DC voltage for the UTC **TDA2005** is 18V.

However the device can withstand a DC voltage up to 28V with no damage. This could occur during winter if two batteries are series connected to crank the engine.

### THERMAL SHUT-DOWN

The presence of a thermal limiting circuit offers the following advantages:

(1). An overload on the output (even if it is permanent), or an excessive ambient temperature can be easily withstood.

(2). The heatsink can have a smaller factor of safety compared with that of a conventional circuit. There is no device damage in the case of excessive junction temperature; all that happens is that  $P_o$  (and therefore  $P_D$ ) and  $I_d$  are reduced.

The maximum allowable power dissipation depends upon the size of the external heatsink (i.e. its thermal resistance); Figure 4 shows the dissipation power as a function of ambient temperature for different thermal resistance.

### LOUDSPEAKER PROTECTION

The circuit offers loudspeaker protection during short circuit for one wire to ground.

## TYPICAL CHARACTERISTICS

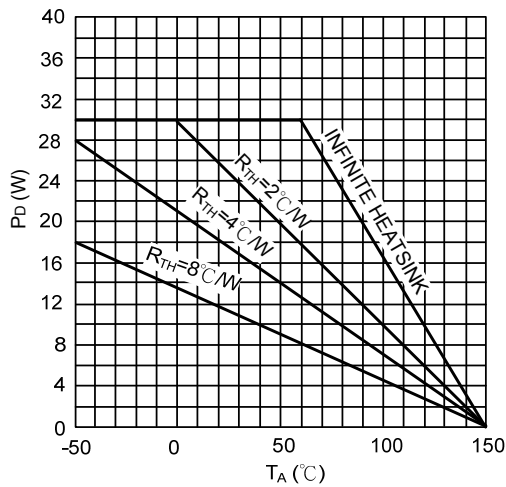

Fig. 4 Maximum Allowable Power Dissipation versus Ambient Temperature

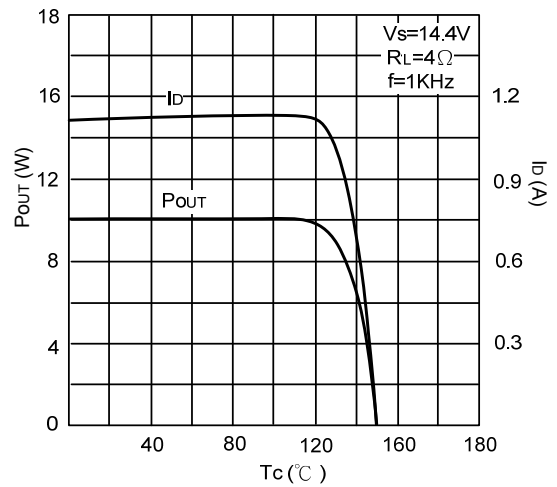

Fig. 5 Output Power and Drain Current Versus Case Temperature

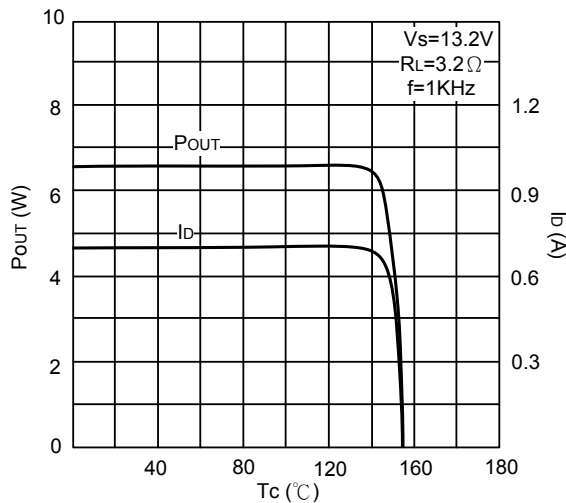

Fig. 6 Output Power and Drain Current Versus Case Temperature

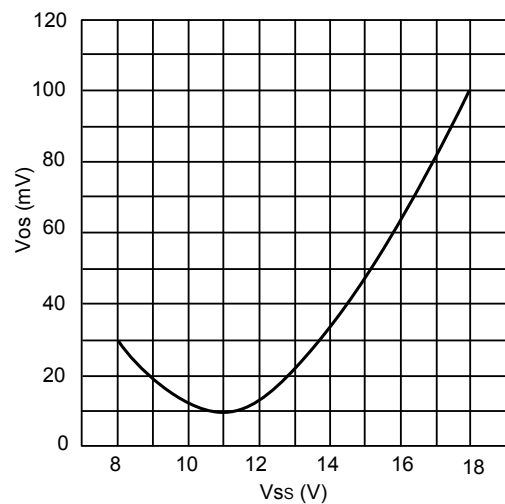

Fig. 7 Output Offset Voltage versus Supply Voltage

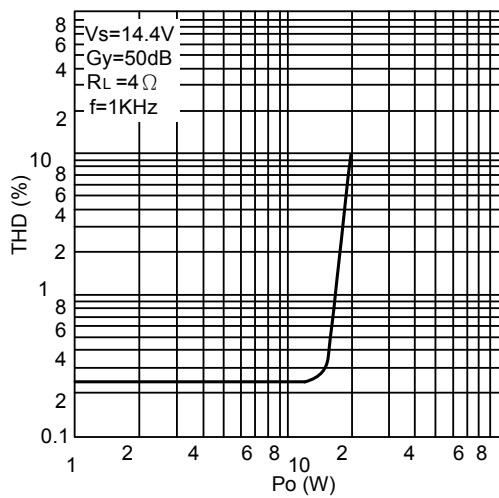

Fig. 8 Distortion versus Output Power (bridge amplifier)

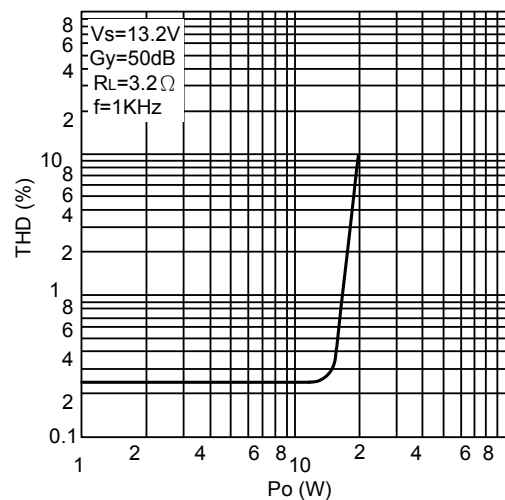

Fig. 9 Distortion versus Output Power (bridge amplifier)

## ■ TYPICAL CHARACTERISTICS (cont.)

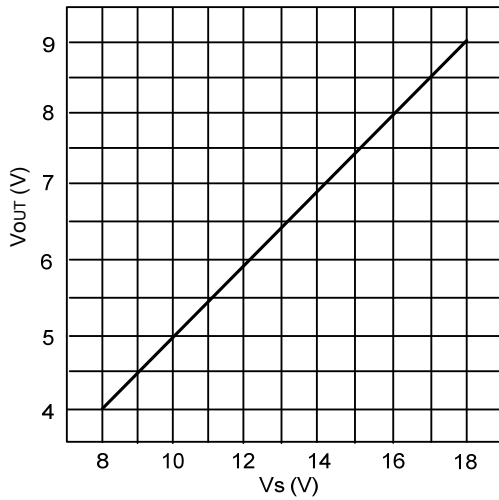

Fig. 10 Quiescent Output Voltage versus Supply Voltage (Stereo amplifier)

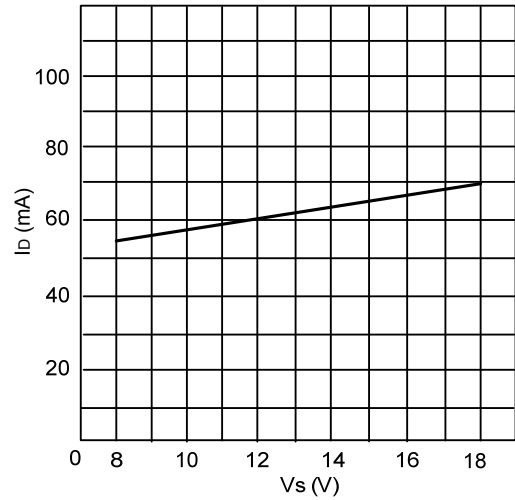

Fig. 11 Quiescent Drain Current versus Supply Voltage (Stereo amplifier)

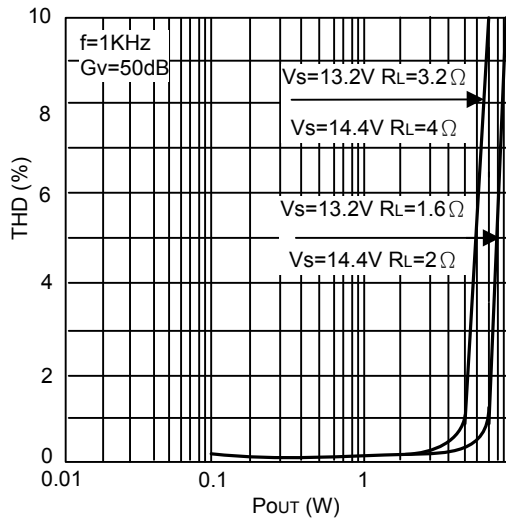

Fig. 12 Distortion versus Output Power (Stereo amplifier)

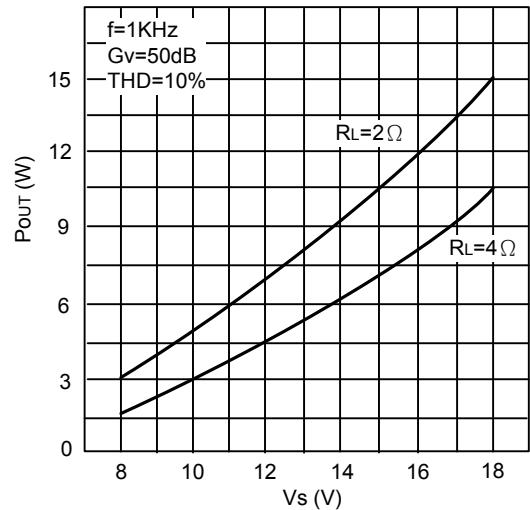

Fig. 13 Output Power versus Supply Voltage (Stereo amplifier)

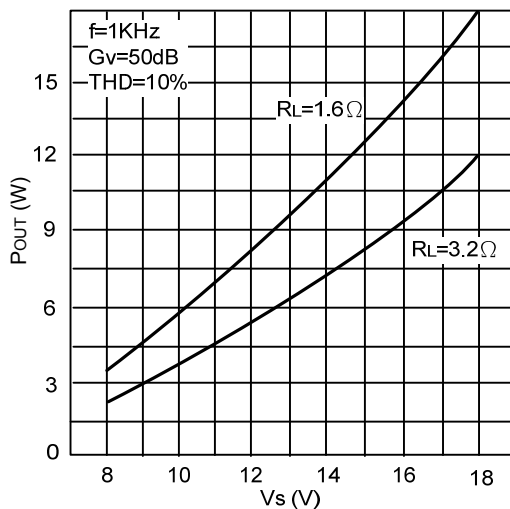

Fig. 14 Output Power versus Supply Voltage (Stereo amplifier)

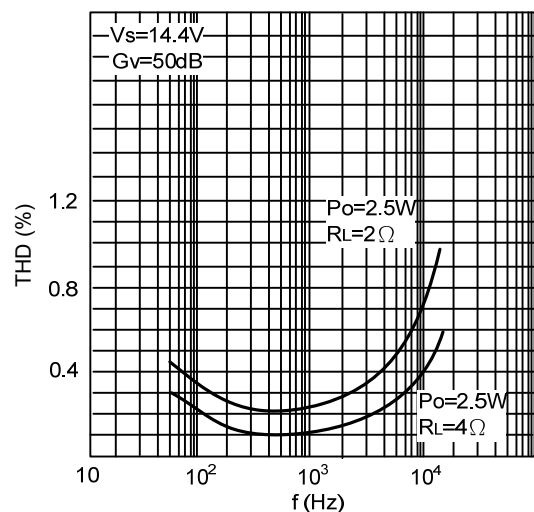

Fig. 15 Distortion versus Frequency (Stereo amplifier)

## ■ TYPICAL CHARACTERISTICS (cont.)

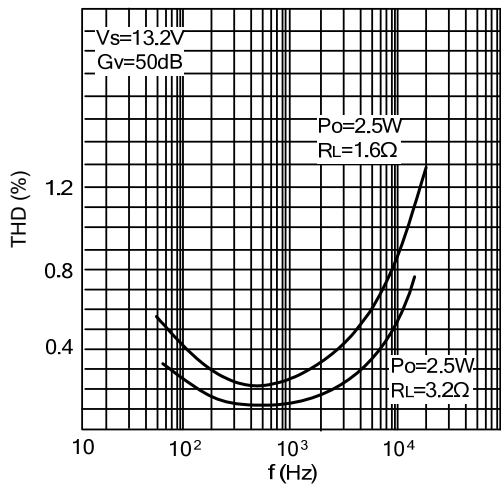

Fig. 16 Distortion versus Frequency (Stereo amplifier)

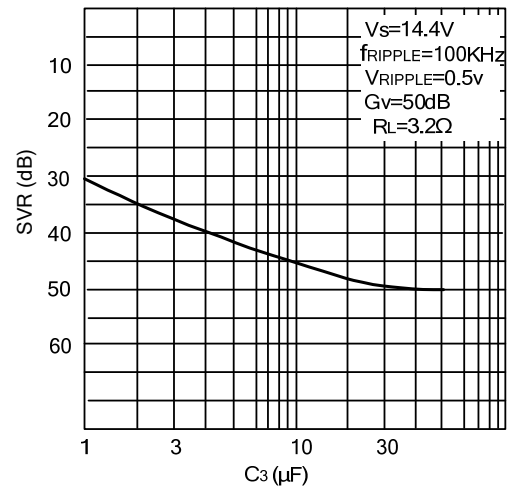

Fig. 17 Supply Voltage Rejection versus C3 (Stereo amplifier)

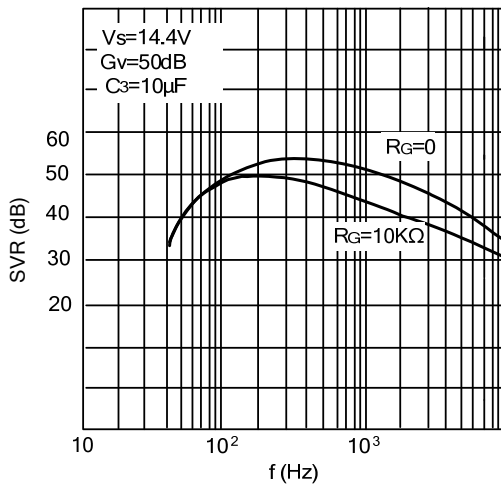

Fig. 18 Supply Voltage Rejection versus Frequency (Stereo amplifier)

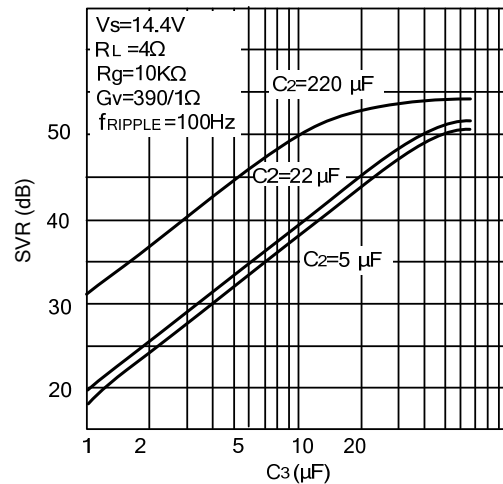

Fig. 19 Supply Voltage Rejection versus C2 and C3 (Stereo amplifier)

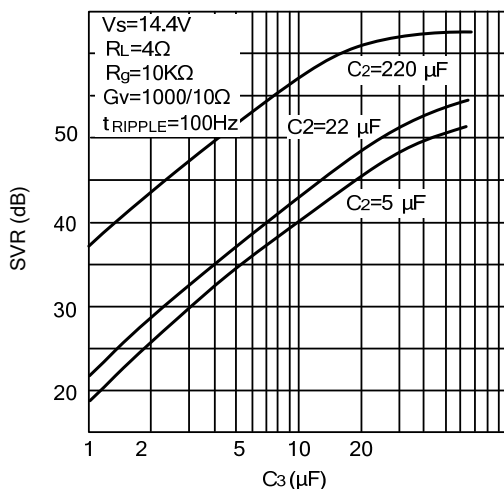

Fig. 20 Supply Voltage Rejection versus C2 and C3 (Stereo amplifier)

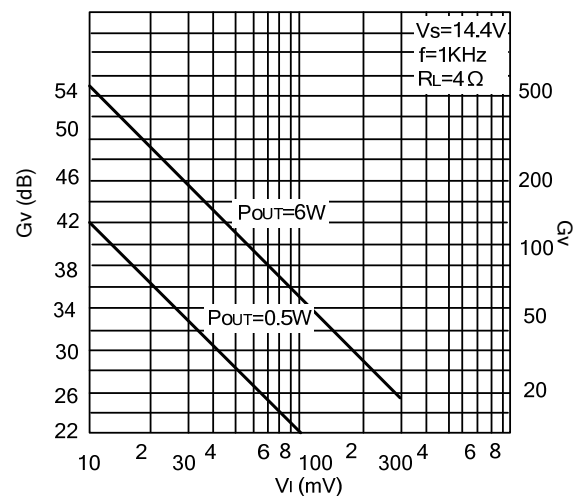

Fig. 21 Gain versus Input Sensitivity (Stereo amplifier)

■ TYPICAL CHARACTERISTICS (cont.)

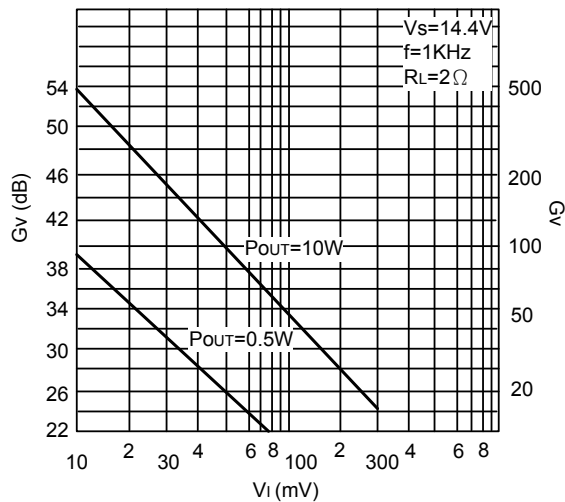

Fig. 22 Gain versus Input Sensitivity (Stereo amplifier)

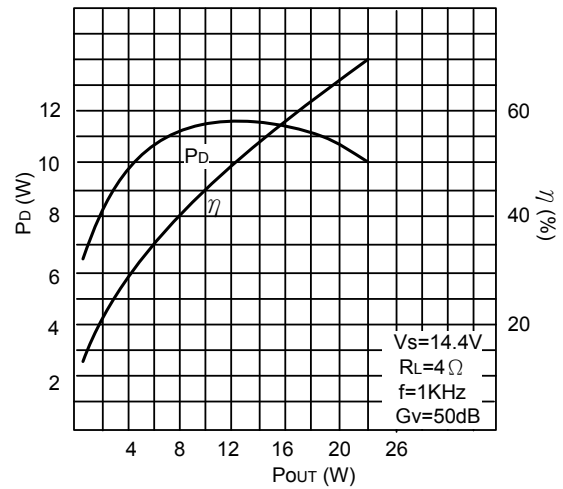

Fig. 23 Total Power Dissipation and Efficiency versus Output Power (Bridge amplifier)

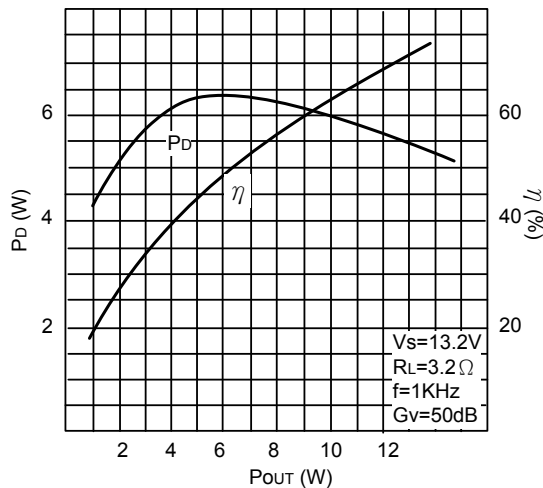

Fig. 24 Total Power Dissipation and Efficiency versus Output Power (Stereo amplifier)

UTC assumes no responsibility for equipment failures that result from using products at values that exceed, even momentarily, rated values (such as maximum ratings, operating condition ranges, or other parameters) listed in products specifications of any and all UTC products described or contained herein. UTC products are not designed for use in life support appliances, devices or systems where malfunction of these products can be reasonably expected to result in personal injury. Reproduction in whole or in part is prohibited without the prior written consent of the copyright owner. The information presented in this document does not form part of any quotation or contract, is believed to be accurate and reliable and may be changed without notice.