



# U74ACT04

CMOS IC

## HEX INVERTERS

### DESCRIPTION

The UTC **U74ACT04** contains six independent inverters and each of them performs the Boolean function  $Y = \bar{A}$ .

### FEATURES

\* Inputs are TTL Voltage Compatible

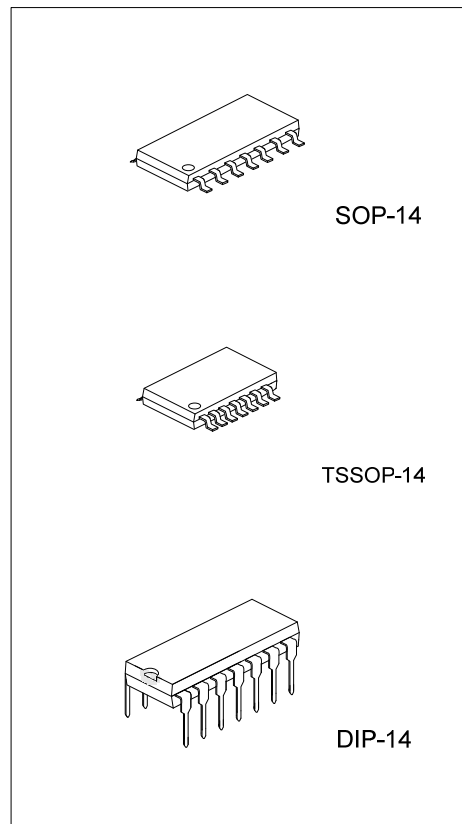

### ORDERING INFORMATION

Ordering Number		Package	Packing
Lead Free	Halogen Free		
U74ACT04L-S14-R	U74ACT04G-S14-R	SOP-14	Tape Reel
U74ACT04L-P14-R	U74ACT04G-P14-R	TSSOP-14	Tape Reel
U74ACT04L-D14-T	U74ACT04G-D14-T	DIP-14	Tube

<p>U74ACT04G-S14-L</p> <p>(1)Packing Type (2)Package Type (3)Lead Free</p>	<p>(1) R: Tape Reel, T: Tube (2) S14: SOP-14, D14: DIP-14, P14: TSSOP-14 (3) G: Halogen Free, L: Lead Free</p>
--	--

■ PIN CONFIGURATION

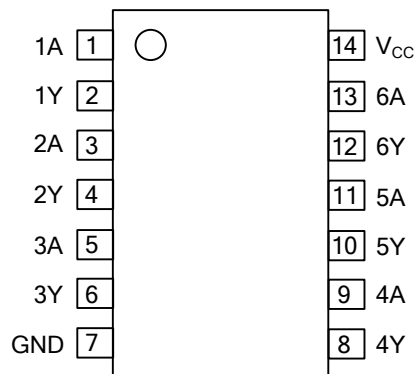

■ FUNCTIONAL DIAGRAM

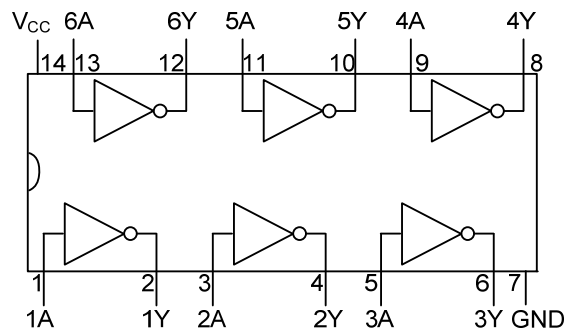

■ FUNCTION TABLE

INPUT(A)	OUTPUT(Y)
L	H
H	L

Note: H=High level; L=Low Level

■ LOGIC DIAGRAM

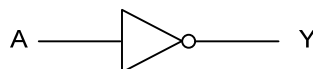

## ■ ABSOLUTE MAXIMUM RATING

PARAMETER		SYMBOL	RATINGS	UNIT
DC Supply Voltage		$V_{CC}$	-0.5 ~ 7	V
Input Voltage		$V_{IN}$	-0.5 ~ $V_{CC}+0.5$	V
Output Voltage		$V_{OUT}$	-0.5 ~ $V_{CC}+0.5$	V
DC Input Clamp Current	For $V_{IN} < 0$ or $V_{IN} > V_{CC}$	$I_{IK}$	$\pm 20$	mA
DC Output Clamp Current	For $V_{OUT} < 0$ or $V_{OUT} > V_{CC}$	$I_{OK}$	$\pm 20$	mA
Continuous Output Current	For $V_{OUT}=0$ to $V_{CC}$	$I_{OUT}$	$\pm 50$	mA
Continuous Current Through $V_{CC}$ or GND			$\pm 200$	mA
Operating Temperature		$T_{OPR}$	-40 ~ +85	°C
Storage Temperature		$T_{STG}$	-65 ~ +150	°C

Note: Absolute maximum ratings are those values beyond which the device could be permanently damaged.  
 Absolute maximum ratings are stress ratings only and functional device operation is not implied.

## ■ THERMAL DATA

PARAMETER		SYMBOL	RATINGS	UNIT
Junction to Ambient	DIP-14	$\theta_{JA}$	81	°C/W
	SOP-14		112	
	TSSOP-14		141	

## ■ ELECTRICAL CHARACTERISTICS ( $T_A=25^\circ\text{C}$ , unless otherwise specified)

PARAMETER	SYMBOL	TEST CONDITIONS	MIN	TYP	MAX	UNIT	
Supply Voltage	$V_{CC}$		4.5		5.5	V	
High Level Input Voltage	$V_{IH}$	$V_{CC}=4.5\sim 5.5\text{V}$	2			V	
Low Level Input Voltage	$V_{IL}$	$V_{CC}=4.5\sim 5.5\text{V}$			0.8	V	
High Level Output Voltage	$V_{OH}$	$V_{CC}=4.5\text{V}$	-50 $\mu\text{A}$	4.4	4.49	V	
		$V_{CC}=5.5\text{V}$		5.4	5.49	V	
		$V_{CC}=4.5\text{V}$	-24 mA	3.86		V	
		$V_{CC}=5.5\text{V}$		4.86		V	
Low Level Output Voltage	$V_{OL}$	$V_{CC}=4.5\text{V}$	-50 $\mu\text{A}$		0.001	0.1	V
		$V_{CC}=5.5\text{V}$			0.001	0.1	V
		$V_{CC}=4.5\text{V}$	24mA			0.36	V
		$V_{CC}=5.5\text{V}$				0.36	V
Input Leakage Current	$I_{I(Leak)}$	$V_{CC}=5.5\text{V}$ , $V_{IN}=V_{CC}$ or GND			$\pm 0.1$	$\mu\text{A}$	
Quiescent Device Current	$I_Q$	$V_{CC}=5.5\text{V}$ , $V_{IN}=V_{CC}$ or GND, $I_{OUT}=0$			2	$\mu\text{A}$	
Additional quiescent Supply Current	$\Delta I_Q$	$V_{CC}=5.5\text{V}$ , One input at 3.4V, Other inputs at GND or $V_{CC}$		0.6		mA	
Input Capacitance	$C_{IN}$	$V_{CC}=5\text{V}$ , $V_{IN}=V_{CC}$ or GND		4.5		pF	

## ■ SWITCHING SPECIFICATIONS ( $T_A=25^\circ\text{C}$ , Input $t_R$ , $t_F = 2.5\text{ns}$ )

PARAMETER	SYMBOL	TEST CONDITIONS	MIN	TYP	MAX	UNIT
Propagation Delay, A to Y	$t_{PLH}$	$V_{CC}=5\pm 0.5\text{V}$ , $C_L=50\text{pF}$ , $R_L=500\Omega$	1	6	8.5	ns
	$t_{PHL}$	$V_{CC}=5\pm 0.5\text{V}$ , $C_L=50\text{pF}$ , $R_L=500\Omega$	1	5.5	8	ns
Power Dissipation Capacitance (Notes 1, 2)	$C_{PD}$	$V_{CC}=5\text{V}$ , $C_L=50\text{pF}$ , $f=1\text{MHz}$		45		pF

Note 1.  $C_{PD}$  is used to determine the dynamic power consumption, per inverter.

2.  $P_D = V_{CC}^2 f_i (C_{PD} + C_L)$  where  $f_i$  = Input Frequency,  $C_L$  = Output Load Capacitance,  $V_{CC}$  = Supply Voltage.

## ■ TEST CIRCUITS AND WAVEFORMS

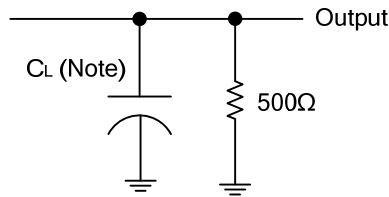

Fig.1: Load circuitry for switching times.  
 Note:  $C_L$  includes probe and jig capacitance.

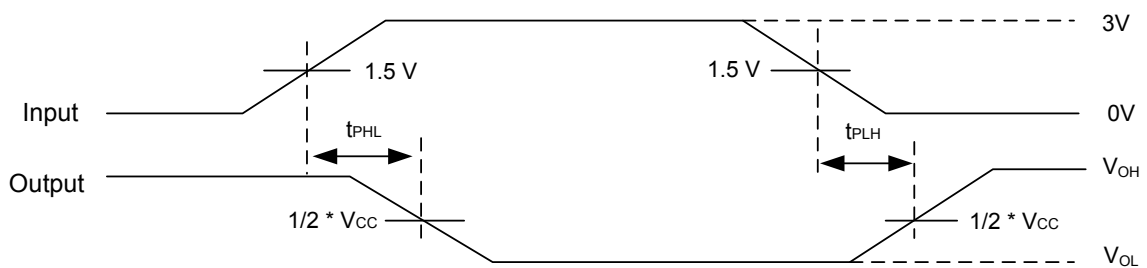

Fig.2: Propagation delay from Input(A) to Output(Y).

UTC assumes no responsibility for equipment failures that result from using products at values that exceed, even momentarily, rated values (such as maximum ratings, operating condition ranges, or other parameters) listed in products specifications of any and all UTC products described or contained herein. UTC products are not designed for use in life support appliances, devices or systems where malfunction of these products can be reasonably expected to result in personal injury. Reproduction in whole or in part is prohibited without the prior written consent of the copyright owner. The information presented in this document does not form part of any quotation or contract, is believed to be accurate and reliable and may be changed without notice.