



LM4811

Preliminary

CMOS IC

DUAL 105mW HEADPHONE AMPLIFIER WITH DIGITAL VOLUME CONTROL AND SHUTDOWN MODE

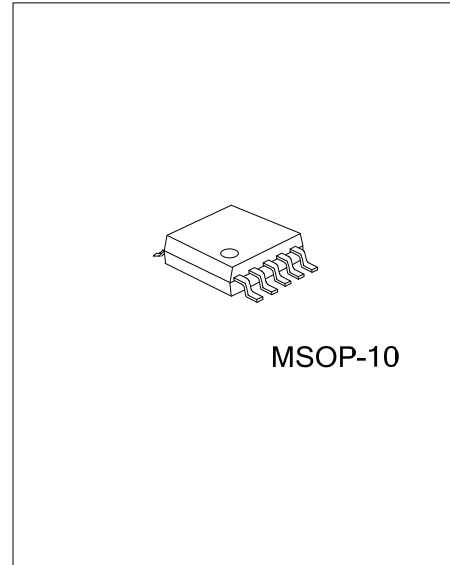

MSOP-10

DESCRIPTION

The UTC **LM4811** is a dual audio power amplifier with digital volume control and shutdown mode function. It is featured in unity-gain stability. The digital volume control sets the amplifier's gain from +12dB to -33dB in 16 discrete steps using a two-wire interface. The shutdown mode is externally controlled, active-high and micropower consumption. An internal thermal shutdown protection circuit is contained in the device.

Operating on a 5V power supply, it can drive 16Ω load at 105mW per channel of continuous average power with 0.1% (THD+N).

This device is mainly used to provide customers with higher quality output power but less required external components. The UTC **LM4811** reduces the use of bootstrap capacitors or snubber networks that make making it ideal for low-power portable systems applications.

The UTC **LM4811** is generally applied in cellular phones, MP3, CD, DVD players, PDA's and other portable electronics.

FEATURES

- * Digital volume control range: +12dB~ -33dB
- * "Click and Pop" suppression circuitry
- * Saving the use of bootstrap capacitors
- * Low shutdown current

ORDERING INFORMATION

| Ordering Number | | Package | Packing |
|-----------------|---------------|---------|-----------|
| Lead Free | Halogen Free | | |
| LM4811L-SM2-R | LM4811G-SM2-R | MSOP-10 | Tape Reel |

| | |
|----------------------------------------------------------------------------------|------------------------------------------------------------------------------------|
| <p>LM4811L-SM2-R</p> <p>(1)Packing Type (2)Package Type (3)Lead Free</p> | <p>(1) R: Tape Reel (2) SM2: MSOP-10 (3) G: Halogen Free, L: Lead Free</p> |
|----------------------------------------------------------------------------------|------------------------------------------------------------------------------------|

■ PIN CONFIGURATION

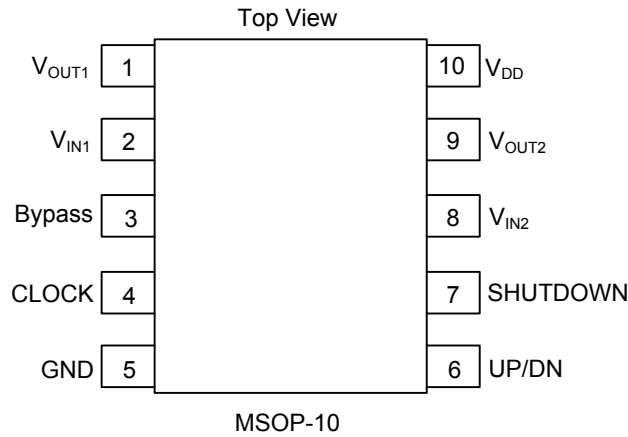

■ PIN DESCRIPTION

| PIN NO. | PIN NAME | DESCRIPTION |
|---------|-------------------|-------------------------------------------------------------------------------------------|
| 1 | V _{OUT1} | Channel 1 output |
| 2 | V _{IN1} | Channel 1 audio input |
| 3 | Bypass | Connect to internal voltage divider for middle supply bias |
| 4 | CLOCK | External clock input for the volume control |
| 5 | GND | Ground |
| 6 | UP/DN | Volume UP/DOWN control |
| 7 | SHUTDOWN | Shutdown mode control input, high active, place LM4811 into shutdown mode, when held high |
| 8 | V _{IN2} | Channel 2 audio input |
| 9 | V _{OUT2} | Channel 2 output |
| 10 | V _{DD} | Supply voltage |

■ BLOCK DIAGRAM

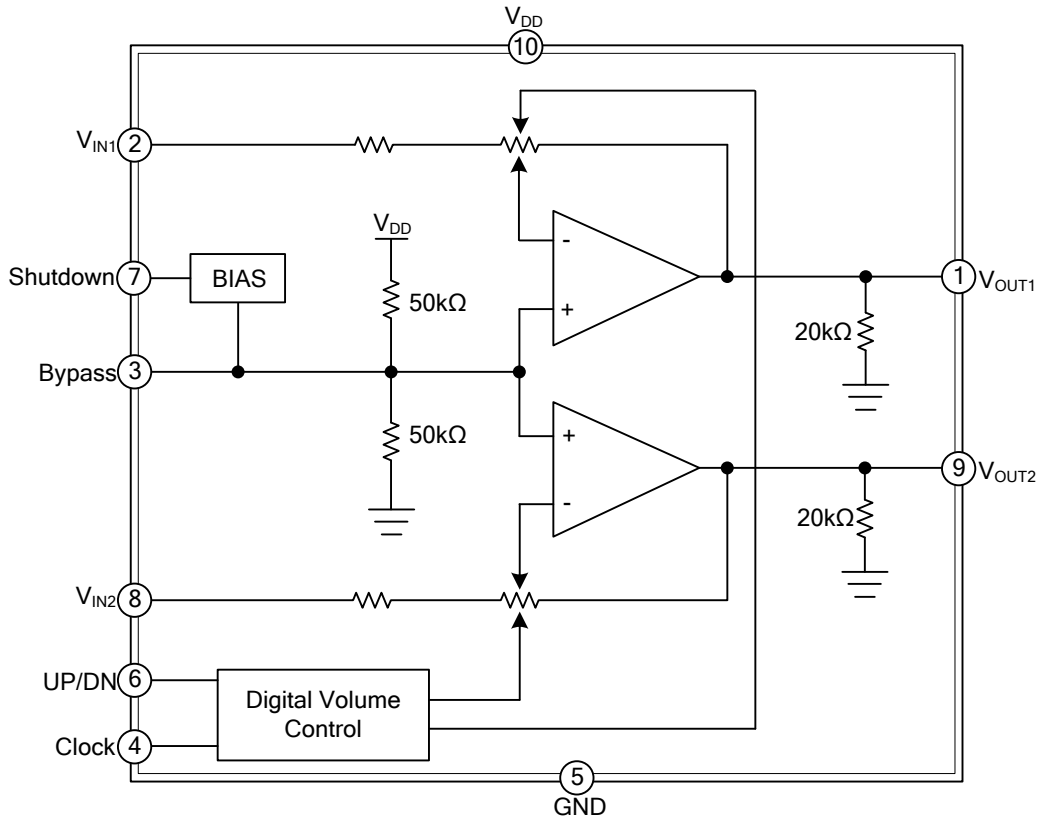

■ **ABSOLUTE MAXIMUM RATING** ($T_C = 25^\circ\text{C}$, unless otherwise specified)

| PARAMETER | SYMBOL | RATINGS | UNIT |
|----------------------|-----------|-----------|------------------|
| Supply Voltage | V_{CC} | 6.0 | V |
| Junction Temperature | T_J | 150 | $^\circ\text{C}$ |
| Storage Temperature | T_{STG} | -65~ +150 | $^\circ\text{C}$ |

Notes: 1. Absolute maximum ratings are those values beyond which the device could be permanently damaged.
Absolute maximum ratings are stress ratings only and functional device operation is not implied.

■ **THERMAL DATA**

| PARAMETER | SYMBOL | RATINGS | UNIT |
|---------------------|---------------|---------|---------------------------|
| Junction to Ambient | θ_{JA} | 194 | $^\circ\text{C}/\text{W}$ |
| Junction to Case | θ_{JC} | 52 | $^\circ\text{C}/\text{W}$ |

■ **OPERATING RATINGS**

| PARAMETER | SYMBOL | RATINGS | UNIT |
|-----------------------|----------|-----------|------------------|
| Supply Voltage | V_{CC} | 2.0 ~ 5.5 | V |
| Operating Temperature | T_A | -40 ~ 85 | $^\circ\text{C}$ |

■ **ELECTRICAL CHARACTERISTICS** ($T_A=25^\circ\text{C}$, unless otherwise specified) (Note 4, 5)

For $V_{DD}=5\text{V}$

| PARAMETER | SYMBOL | TEST CONDITIONS | MIN | TYP | MAX | UNIT |
|-------------------------------------------|--------------------------------------|--------------------------------------------------------------------|----------------|-----------|-----|---------------|
| Supply Voltage | V_{DD} | | 2.0 | | 5.5 | V |
| Supply Current | I_{DD} | $V_{IN}=0\text{V}, I_O=0\text{A}$ | | 1.3 | 3.0 | mA |
| Shutdown Current | I_{SD} | $V_{IN}=0\text{V}$ | | 0.3 | | μA |
| Output Offset Voltage | V_{OS} | $V_{IN}=0\text{V}$ | | 4.0 | 50 | mV |
| Output Power | P_O | THD+N=0.1%, f=1kHz | $R_L=16\Omega$ | 105 | | mW |
| | | | $R_L=32\Omega$ | 70 | | mW |
| Total Harmonic Distortion | THD+N | $P_O=50\text{mW}, R_L=32\Omega, f=20\text{Hz}\sim 20\text{kHz}$ | | 0.3 | | % |
| Channel Separation | Crosstalk | $R_L=32\Omega, f=1\text{kHz}, P_O=70\text{mW}$ | | 100 | | dB |
| Power Supply Rejection Ratio | PSRR | $C_B=1.0\mu\text{F}, V_{RIPPLE}=100\text{mV}_{PP}, f=217\text{Hz}$ | | 60 | | dB |
| Input Voltage (Clock, UP/DN, Shutdown) | High | V_{IH} | 1.4 | | | V |
| | Low | V_{IL} | | | 0.4 | V |
| Digital Volume Range | Input referred minimum gain | | | -33 | | dB |
| | Input referred maximum gain | | | +12 | | dB |
| Digital Volume Step Size | All 16 discrete steps | | | 3.0 | | dB |
| Step Size Error | All 16 discrete steps | | | ± 0.3 | | dB |
| Channel-to-Channel Volume Tracking Error | All gain settings from -33dB ~ +12dB | | | 0.15 | | dB |
| Shutdown Attenuation | Shutdown mode active | | | -100 | | dB |

■ ELECTRICAL CHARACTERISTICS(Cont.)

For $V_{DD}=3.3V$

| PARAMETER | SYMBOL | TEST CONDITIONS | MIN | TYP | MAX | UNIT |
|-------------------------------------------|----------|------------------------------------------------|----------------|-----------|-----|---------|
| Supply Current | I_{DD} | $V_{IN}=0V, I_O=0A$ | | 1.1 | | mA |
| Shutdown Current | I_{SD} | $V_{IN}=0V$ | | 0.3 | | μA |
| Output Offset Voltage | V_{OS} | $V_{IN}=0V$ | | 4.0 | | mV |
| Output Power | P_O | THD+N=0.1%, f=1kHz | $R_L=16\Omega$ | 40 | | mW |
| | | | $R_L=32\Omega$ | 28 | | mW |
| Total Harmonic Distortion | THD+N | $P_O=25mW, R_L=32\Omega, f=20Hz\sim 20kHz$ | | 0.5 | | % |
| Power Supply Rejection Ratio | PSRR | $C_B=1.0\mu F, V_{RIPPLE}=100mV_{PP}, f=217Hz$ | | 60 | | dB |
| Input Voltage (Clock, UP/DN, Shutdown) | High | V_{IH} | 1.4 | | | V |
| | Low | V_{IL} | | | 0.4 | V |
| Digital Volume Range | | Input referred minimum gain | | -33 | | dB |
| | | Input referred maximum gain | | +12 | | dB |
| Digital Volume Step Size | | All 16 discrete steps | | 3.0 | | dB |
| Step Size Error | | All 16 discrete steps | | ± 0.3 | | dB |
| Channel-to-Channel Volume Tracking Error | | All gain settings from -33dB ~ +12dB | | 0.15 | | dB |
| Shutdown Attenuation | | Shutdown mode active | | -100 | | dB |

For $V_{DD}=2.6V$

| PARAMETER | SYMBOL | TEST CONDITIONS | MIN | TYP | MAX | UNIT |
|-------------------------------------------|----------|------------------------------------------------|----------------|-----------|-----|---------|
| Supply Current | I_{DD} | $V_{IN}=0V, I_O=0A$ | | 1.0 | | mA |
| Shutdown Current | I_{SD} | $V_{IN}=0V$ | | 0.3 | | μA |
| Output Offset Voltage | V_{OS} | $V_{IN}=0V$ | | 4.0 | | mV |
| Output Power | P_O | THD+N=0.1%, f=1kHz | $R_L=16\Omega$ | 20 | | mW |
| | | | $R_L=32\Omega$ | 16 | | mW |
| Total Harmonic Distortion | THD+N | $P_O=15mW, R_L=32\Omega, f=20Hz\sim 20kHz$ | | 0.6 | | % |
| Power Supply Rejection Ratio | PSRR | $C_B=1.0\mu F, V_{RIPPLE}=100mV_{PP}, f=217Hz$ | | 60 | | dB |
| Input Voltage (Clock, UP/DN, Shutdown) | High | V_{IH} | 1.4 | | | V |
| | Low | V_{IL} | | | 0.4 | V |
| Digital Volume Range | | Input referred minimum gain | | -33 | | dB |
| | | Input referred maximum gain | | +12 | | dB |
| Digital Volume Step Size | | All 16 discrete steps | | 3.0 | | dB |
| Step Size Error | | All 16 discrete steps | | ± 0.3 | | dB |
| Channel-to-Channel Volume Tracking Error | | All gain settings from -33dB ~ +12dB | | 0.15 | | dB |
| Shutdown Attenuation | | Shutdown mode active | | -75 | | dB |

Notes: 4. Absolute Maximum Ratings indicate limits beyond which damage to the device may occur.

5. All voltages are measured with respect to the ground pin, unless otherwise specified.

APPLICATION INFORMATION

DIGITAL VOLUME CONTROL

The UTC **LM4811** is dual audio power amplifier with digital volume control and shutdown mode function. The CLOCK pin is driven by an external clock. Its gain is controlled by the signals applied to the CLOCK and UP/DN inputs.

The audio power amplifier's gain is fixed by the signals, which are applied to the CLOCK and UP/DN inputs. The gain is controlled by the logic voltage level applied to the UP/DN pin at each rising edge of the clock signal. At each rising edge of the clock signal, when a logic high voltage level is applying to the UP/DN pin, 3dB is increased, in verse when a logic low voltage is applying to the UP/DN pin, 3dB is decreased on the contrary. For both the CLOCK and UP/DN inputs, the trigger point is 1.4V (MIN.) for a logic high level, and 0.4V (MAX.) for a logic low level.

The UTC **LM4811** contains 16 discrete gain settings varying from +12dB (MAX.) to -33dB (MIN.), amplifier's gain is set to a default value of 0dB during power on condition. However, when coming out of shutdown mode, the UTC **LM4811** will revert back to its previous gain setting.

In order to avoid undesired state changes during transitions between V_{IL} and V_{IH} , the UTC **LM4811**'s CLOCK and UP/DN pins should be debounced. This will ensure correct operation of the digital volume control. A microcontroller or microprocessor output is expected to drive the CLOCK and UP/DN pins.

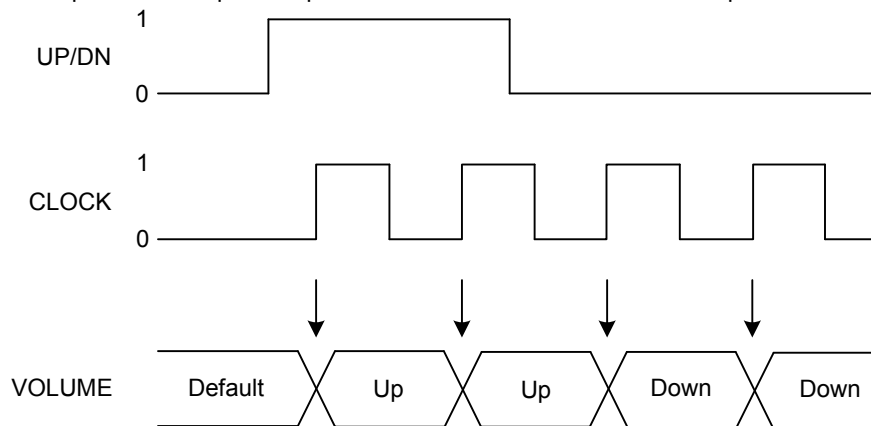

Figure 2. Timing Diagram

POWER SUPPLY BYPASSING

To obtain low noise performance and high power supply rejection, proper supply bypassing is essentially needed for any power amplifier. Capacitor on both the bypass and power supply pins should be placed closely as possible. Bypass capacitor value is also critical as it directly affects the device's half-supply voltage stability and PSRR. The stability and supply rejection increase as the bypass capacitor's value increases. In the typical applications, employing a 5V regulator with 10 μ F and a 0.1 μ F bypass capacitors which aid in supply stability. This, however, is not saving the need for bypassing the supply nodes of the UTC **LM4811**. The issue of selecting bypass capacitors, especially C_B , is thus dependent upon desired low frequency PSRR, click and pop performance, system cost, and size constraints.

SHUTDOWN FUNCTION

The UTC **LM4811** contains a bias circuitry shutdown to reduce power consumption while not in use. By applying a logic high to the SHUTDOWN pin, the shutdown function is active. For a logic high level, the trigger point is 1.4V (MIN.), and 0.4V (MAX.) for a logic low. For a better shutdown performance, it is best to switch between ground and V_{DD} . By switching the SHUTDOWN pin to V_{DD} , the UTC **LM4811** supply current draw will be minimized in idle mode. Whereas the device will be disabled with shutdown voltages less than V_{DD} , the idle current may be greater than 0.3 μ A (TYP.). In either case, the SHUTDOWN pin should be tied to a fixed voltage to avoid undesired state changes.

In many applications, a microcontroller or microprocessor output is used to control the shutdown circuitry. This provides a quick, smooth shutdown transition. Another solution is to use a single-pole, single-throw switch in conjunction with an external pull-up resistor. When the switch is closed, the SHUTDOWN pin is connected to ground and enables the amplifier. If the switch is open, the external pull-up resistor, R_{PU} , will disable the UTC **LM4811**. This scheme guarantees that the SHUTDOWN pin will not float, thus preventing undesired state changes.

■ APPLICATION INFORMATION(Cont.)

PROPER SELECTION OF EXTERNAL COMPONENTS

In applications, selection of external components when using integrated power amplifiers is critical for optimum device and system performance. Moreover, the values of external components are also important to consider as they directly affect the overall system quality. The UTC **LM4811** is tolerant to a variety of external component combinations.

The UTC **LM4811** is unity-gain stable, providing designers maximize system performance. Low gain settings maximize signal-to-noise performance and minimize THD+N. Low gain configurations require large input signals to obtain a given output power. Input signals reach 1V_{rms} or higher are available from sources such as audio codecs.

SELECTION OF INPUT AND OUTPUT CAPACITOR SIZE

Another consideration is the closed loop bandwidth besides gain. To a large extent, the bandwidth is dictated by the choice of external components shown in Figure 1. Both the C_I (input coupling capacitor) and the C_O (output coupling capacitor) form first order high pass filters which limit low frequency response. The values of these capacitors should be based on the desired frequency response weighed against the following:

Large value input and output capacitors are both expensive and space consuming for portable designs. Clearly a certain sized capacitor is needed to couple in low frequencies without severe attenuation. But in many cases the speakers used in portable systems, whether internal or external, have little ability to reproduce signals below 150Hz. Thus large input and output capacitors may not increase system performance.

Moreover, for the system cost and size, click and pop performance is affected by the size of the C_I (input coupling capacitor). A larger input coupling capacitor requires more charge to reach its quiescent DC voltage (nominally $1/2 V_{DD}$). This charge comes from the output via the feedback and the pops are apt to be generated upon device enable. Reducing the value of input coupling capacitor can minimize the turn on pops, which is based on necessary low frequency response.

The value of bypass capacitor should be taken into consideration besides minimizing the input and output capacitor values. For minimizing turn on pops, the bypass capacitor C_B plays the most important role, since it determines how fast the UTC **LM4811** turns on. The slower the UTC **LM4811**'s outputs ramp to their quiescent DC voltage (nominally $1/2 V_{DD}$), the smaller the turn on pop. While the device will function properly, (no oscillations or motorboating), with C_B equal to $1\mu\text{F}$, the device will be much more susceptible to turn on clicks and pops. Thus, a value of C_B equal to $1\mu\text{F}$ or larger is recommended in all but the most cost sensitive designs.

In addition, the type of capacitors should be given enough consideration since different types of capacitors (tantalum, electrolytic, ceramic) have unique performance characteristics and may affect overall system performance.

■ TYPICAL APPLICATION CIRCUIT

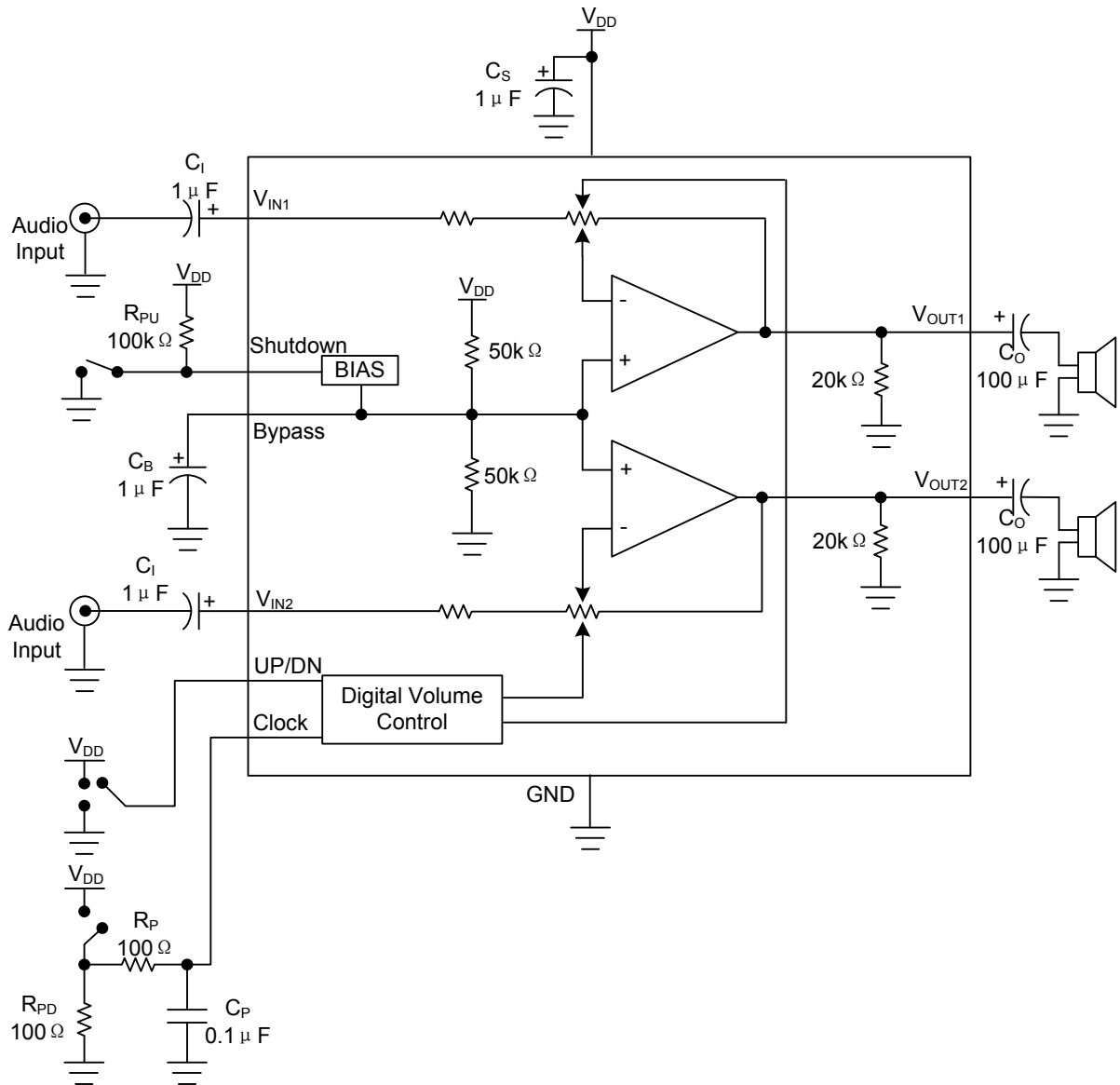

* Refer to the Application Information Section for information concerning proper selection of the input and output coupling capacitors.

Figure 1. Typical Audio Amplifier Application Circuit

■ EXTERNAL COMPONENTS DESCRIPTION

| PIN NO. | PIN NAME | DESCRIPTION |
|---------|----------------|--------------------------------------------------------------------------------------------------------------------------------------------------------------------------------------------------------------------------------------------------------------------------------------------------------------------------------------------------------------------------------------------------------------------------------------------------|
| 1 | C _I | This is the input coupling capacitor. It blocks the DC voltage at, and couples the input signal to, the amplifier's input terminals. C also creates a highpass filter with the internal input resistor, R _I , at $f_c = 1/(2 \pi R_I C_I)$. The minimum value of R _I is 33kΩ. Refer to the section, Proper Selection of External Components , for an explanation of how to determine the value of C _I . |
| 2 | C _S | This is the supply bypass capacitor. It provides power supply filtering. Refer to the Application Information section for proper placement and selection of the supply bypass capacitor. |
| 3 | C _B | This is the BYPASS pin capacitor. It provides half-supply filtering. Refer to the section, Proper Selection of External Components , for information concerning proper placement and selection of C _B . |
| 4 | C _O | This is the output coupling capacitor. It blocks the DC voltage at the amplifier's output and it forms a high pass filter with R _L at $f_O = 1/(2 \pi R_L C_O)$ |

UTC assumes no responsibility for equipment failures that result from using products at values that exceed, even momentarily, rated values (such as maximum ratings, operating condition ranges, or other parameters) listed in products specifications of any and all UTC products described or contained herein. UTC products are not designed for use in life support appliances, devices or systems where malfunction of these products can be reasonably expected to result in personal injury. Reproduction in whole or in part is prohibited without the prior written consent of the copyright owner. The information presented in this document does not form part of any quotation or contract, is believed to be accurate and reliable and may be changed without notice.