



# UT2309

Power MOSFET

## P-CHANNEL ENHANCEMENT MODE

### DESCRIPTION

The **UT2309** is P-channel power MOSFET, designed with high density cell with fast switching speed, ultra low on-resistance and excellent thermal and electrical capabilities.

Used in commercial and industrial surface mount applications and suited for low voltage applications such as DC/DC converters.

### SYMBOL

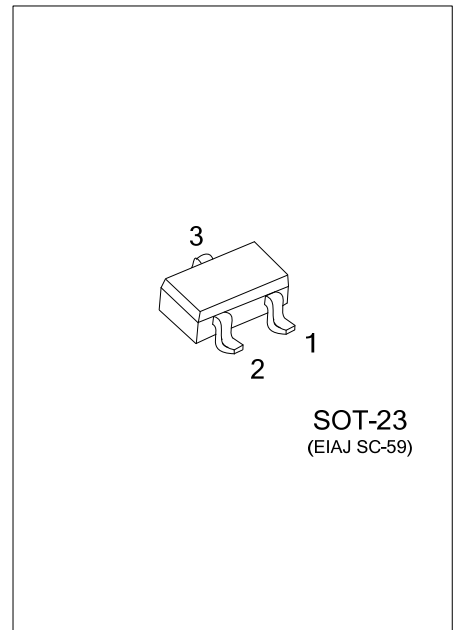
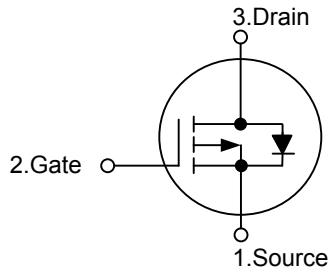

### ORDERING INFORMATION

| Ordering Number |               | Package | Pin Assignment |   |   | Packing   |
|-----------------|---------------|---------|----------------|---|---|-----------|
| Lead Free       | Halogen Free  |         | 1              | 2 | 3 |           |
| UT2309L-AE3-R   | UT2309G-AE3-R | SOT-23  | S              | G | D | Tape Reel |

|                      |  |   |
|----------------------|--|---|
| <p>UT2309L-AE3-R</p> | <p>(1)Packing Type</p> <p>(2)Package Type</p> <p>(3)Lead Plating</p> | <p>(1) R: Tape Reel</p> <p>(2) AE3: SOT-23</p> <p>(3) L: Lead Free, G: Halogen Free</p> |
|----------------------|--|---|

### MARKING

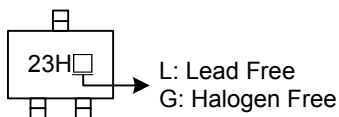

## ■ ABSOLUTE MAXIMUM RATINGS

| PARAMETER                         | SYMBOL    | RATINGS    | UNIT        |
|-----------------------------------|-----------|------------|-------------|
| Drain-Source Voltage              | $V_{DSS}$ | -30        | V           |
| Gate-Source Voltage               | $V_{GSS}$ | $\pm 20$   | V           |
| Continuous Drain Current (Note 3) | $I_D$     | -3.7       | A           |
| Pulsed Drain Current (Note 1, 2)  | $I_{DM}$  | -12        | A           |
| Total Power Dissipation           | $P_D$     | 1.38       | W           |
| Junction Temperature              | $T_J$     | +150       | $^{\circ}C$ |
| Storage Temperature               | $T_{STG}$ | -55 ~ +150 | $^{\circ}C$ |

Note: Absolute maximum ratings are those values beyond which the device could be permanently damaged.

Absolute maximum ratings are stress ratings only and functional device operation is not implied.

## ■ THERMAL DATA

| PARAMETER                    | SYMBOL        | RATINGS | UNIT          |
|------------------------------|---------------|---------|---------------|
| Junction to Ambient (Note 3) | $\theta_{JA}$ | 90      | $^{\circ}C/W$ |

## ■ ELECTRICAL CHARACTERISTICS ( $T_J = 25^{\circ}C$ , unless otherwise specified)

| PARAMETER  | SYMBOL                       | TEST CONDITIONS  | MIN | TYP   | MAX  | UNIT          |
|--|------------------------------|--|-----|-------|------|---------------|
| <b>OFF CHARACTERISTICS</b>                             |                              |  |     |       |      |               |
| Drain-Source Breakdown Voltage                         | $BV_{DSS}$                   | $V_{GS} = 0V, I_D = -250 \mu A$  | -30 |       |      | V             |
| Drain-Source Leakage Current                           | $I_{DSS}$                    | $V_{DS} = -30V, V_{GS} = 0V$   |     |       | -0.5 | $\mu A$       |
| Gate-Source Leakage Current                            | $I_{GSS}$                    | $V_{GS} = \pm 20V, V_{DS} = 0V$  |     |       | 100  | nA            |
| Breakdown Voltage Temperature Coefficient              | $\Delta BV_{DSS}/\Delta T_J$ | Reference to $25^{\circ}C, I_D = -1mA$                                     |     | -0.02 |      | $V/^{\circ}C$ |
| <b>ON CHARACTERISTICS</b>                              |                              |  |     |       |      |               |
| Gate Threshold Voltage                                 | $V_{GS(TH)}$                 | $V_{DS} = V_{GS}, I_D = -250 \mu A$  | -1  |       | -3   | V             |
| Static Drain-Source On-Resistance (Note 2)             | $R_{DS(ON)}$                 | $V_{GS} = -10V, I_D = -3A$   |     |       | 75   | $m\Omega$     |
|  |                              | $V_{GS} = -4.5V, I_D = -2.6A$  |     |       | 120  | $m\Omega$     |
| <b>DYNAMIC CHARACTERISTICS</b>                         |                              |  |     |       |      |               |
| Input Capacitance                                      | $C_{ISS}$                    | $V_{GS} = 0V, V_{DS} = -25V, f = 1.0MHz$                                   |     | 412   | 660  | pF            |
| Output Capacitance                                     | $C_{OSS}$                    |  |     | 91    |      | pF            |
| Reverse Transfer Capacitance                           | $C_{RSS}$                    |  |     | 62    |      | pF            |
| <b>SWITCHING CHARACTERISTICS</b>                       |                              |  |     |       |      |               |
| Turn-ON Delay Time (Note 2)                            | $t_{D(ON)}$                  | $V_{DS} = -15V, I_D = -1A, R_G = 3.3\Omega, V_{GS} = -10V, R_D = 15\Omega$ |     | 8     |      | ns            |
| Turn-ON Rise Time                                      | $t_R$                        |  |     | 5     |      | ns            |
| Turn-OFF Delay Time                                    | $t_{D(OFF)}$                 |  |     | 20    |      | ns            |
| Turn-OFF Fall Time                                     | $t_F$                        | $V_{DS} = -24V, V_{GS} = -4.5V, I_D = -3A$                                 |     | 7     |      | ns            |
| Total Gate Charge (Note 2)                             | $Q_G$                        |  |     | 5     | 8    | nC            |
| Gate-Source Charge                                     | $Q_{GS}$                     |  |     | 1     |      | nC            |
| Gate-Drain Charge                                      | $Q_{GD}$                     |  | 3   |       | nC   |               |
| <b>SOURCE- DRAIN DIODE RATINGS AND CHARACTERISTICS</b> |                              |  |     |       |      |               |
| Forward On Voltage                                     | $V_{SD}$                     | $I_S = -1A, V_{GS} = 0V$   |     | -0.76 | -1.2 | V             |
| Reverse Recovery Time                                  | $t_{RR}$                     | $I_S = -3A, V_{GS} = 0V,$  |     | 20    |      | ns            |
| Reverse Recovery Charge                                | $Q_{RR}$                     | $di/dt = -100A/\mu s$  |     | 15    |      | nC            |

Notes: 1. Pulse width limited by  $T_{J(MAX)}$

2. Pulse width  $\leq 300\mu s$ , duty cycle  $\leq 2\%$ .

3. Surface mounted on 1 in<sup>2</sup> copper pad of FR4 board.

## TYPICAL CHARACTERISTICS

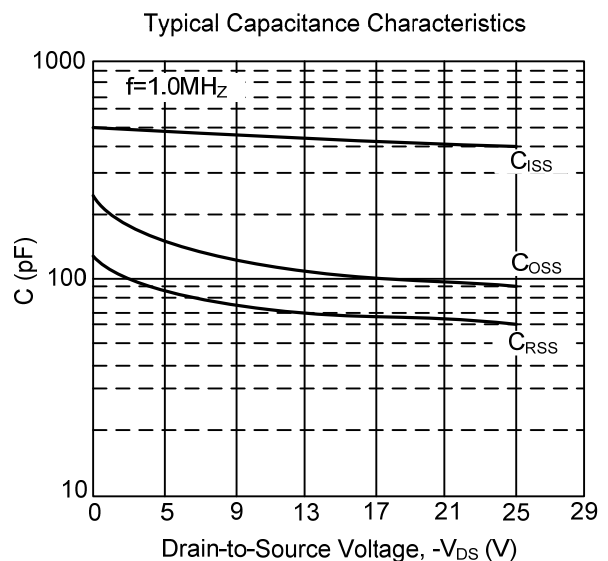
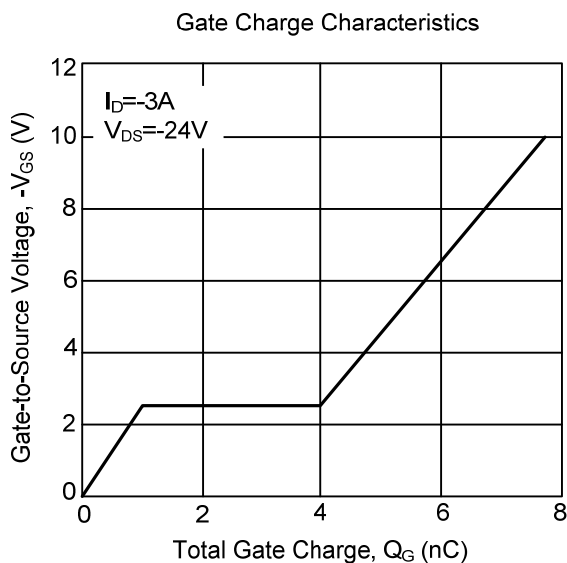
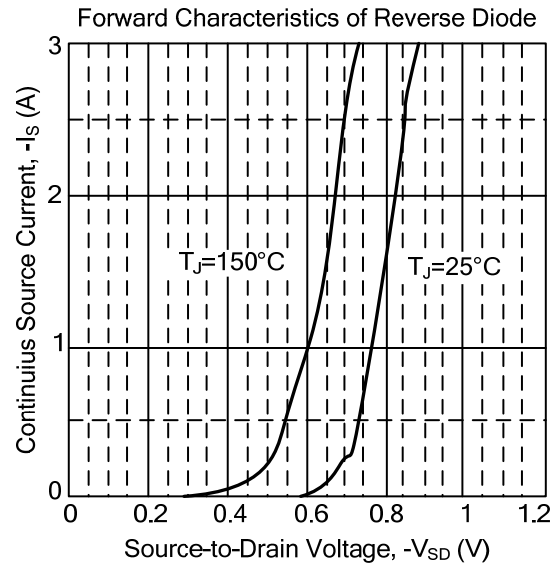
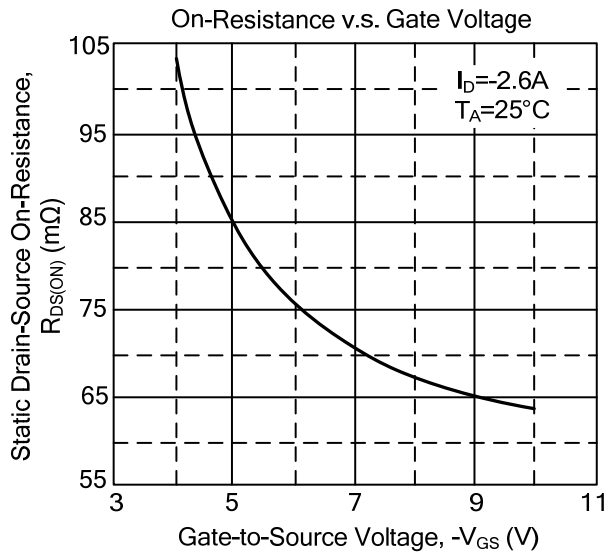
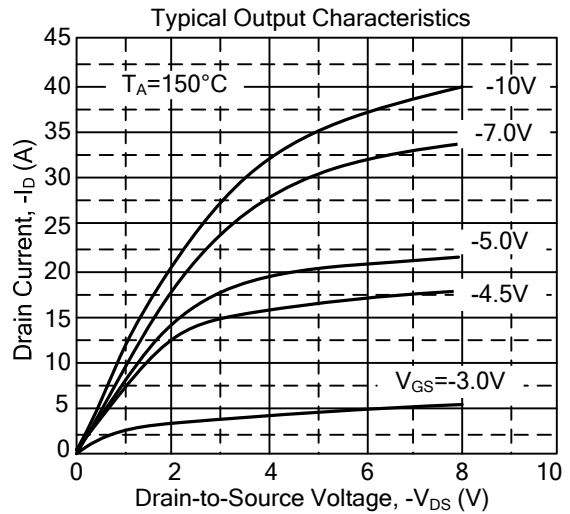
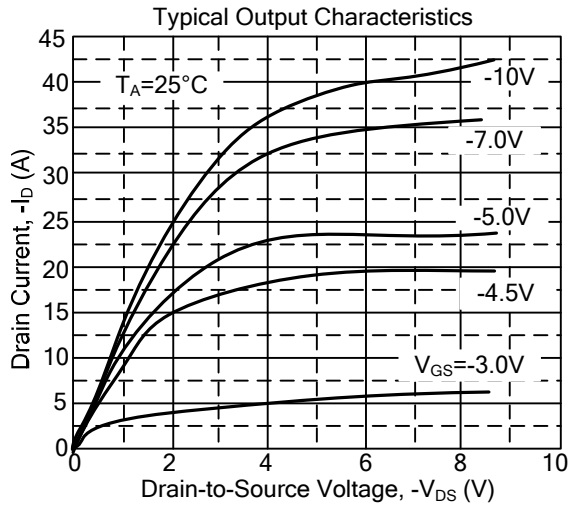

## ■ TYPICAL CHARACTERISTICS(Cont.)

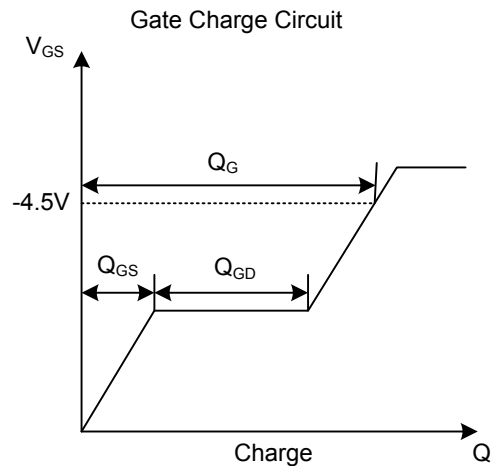
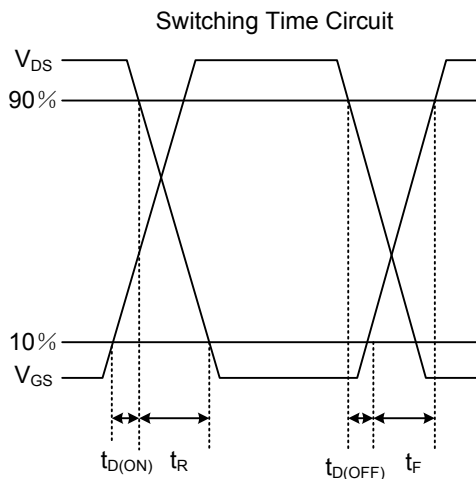
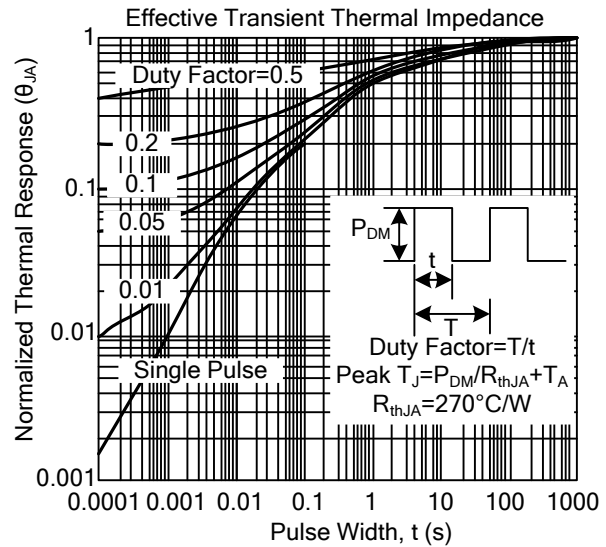
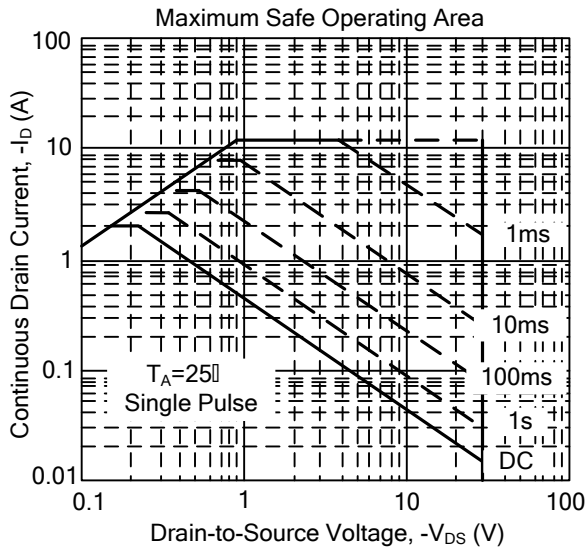

UTC assumes no responsibility for equipment failures that result from using products at values that exceed, even momentarily, rated values (such as maximum ratings, operating condition ranges, or other parameters) listed in products specifications of any and all UTC products described or contained herein. UTC products are not designed for use in life support appliances, devices or systems where malfunction of these products can be reasonably expected to result in personal injury. Reproduction in whole or in part is prohibited without the prior written consent of the copyright owner. The information presented in this document does not form part of any quotation or contract, is believed to be accurate and reliable and may be changed without notice.