



# UN1518

## NPN SILICON TRANSISTOR

### POWER (SWITCHING) TRANSISTOR

#### FEATURES

- \* Bipolar Power Transistor
- \* High Current Switching
- \* High  $h_{FE}$
- \* Low  $V_{CE(SAT)}$

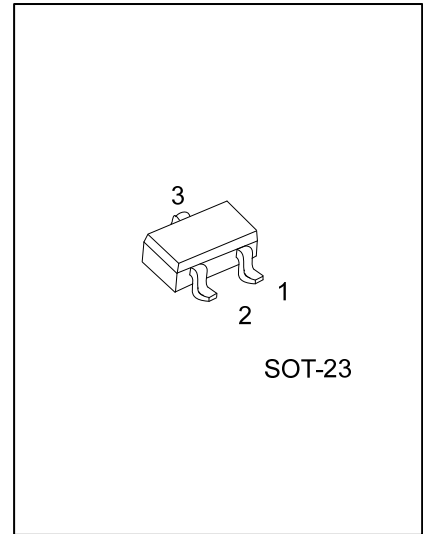

#### ORDERING INFORMATION

Ordering Number		Package	Pin Assignment			Packing
Lead Free Plating	Halogen Free		1	2	3	
UN1518L-AE3-R	UN1518G-AE3-R	SOT-23	E	B	C	Tape Reel

<p>UN1518L-AE3-R</p> <p>(1) Packing Type (2) Package Type (3) Lead Plating</p>	<p>(1) R: Tape Reel (2) AE3: SOT-23 (3) L: Lead Free, G: Halogen Free</p>
--	---

#### MARKING

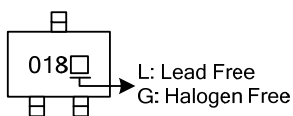

**ABSOLUTE MAXIMUM RATINGS** ( $T_C = 25^\circ\text{C}$ , unless otherwise stated)

PARAMETER		SYMBOL	RATINGS	UNIT
Collector-Base Voltage		$V_{CBO}$	20	V
Collector-Emitter Voltage		$V_{CEO}$	20	V
Emitter-Base Voltage		$V_{EBO}$	5	V
Collector Current	Pulse (Note 2)	$I_{CM}$	6	A
	DC	$I_C$	2.5	A
Base Current		$I_B$	500	mA
Total Device Dissipation		$P_D$	625	mW
Storage Temperature		$T_{STG}$	-50 ~ +150	$^\circ\text{C}$

Notes: 1. Absolute maximum ratings are those values beyond which the device could be permanently damaged.

Absolute maximum ratings are stress ratings only and functional device operation is not implied.

2. Pulse width=300ms. Duty cycle  $\leq 2\%$

### ■ ELECTRICAL CHARACTERISTICS

PARAMETER	SYMBOL	TEST CONDITIONS	MIN	TYP	MAX	UNIT
Collector-Base Breakdown Voltage	$BV_{CBO}$	$I_C=100\mu\text{A}$	20	100		V
Collector-Emitter Breakdown Voltage	$BV_{CEO}$	$I_C=10\text{mA}$ (Note)	20	27		V
Emitter-Base Breakdown Voltage	$BV_{EBO}$	$I_E=100\mu\text{A}$	5	8.3		V
Collector Cut-Off Current	$I_{CBO}$	$V_{CB}=16\text{V}$			100	nA
Emitter Cut-Off Current	$I_{EBO}$	$V_{EB}=4\text{V}$			100	nA
Collector Emitter Cut-Off Current	$I_{CES}$	$V_{CES}=16\text{V}$			100	nA
Collector-Emitter Saturation Voltage (Note)	$V_{CE(SAT)}$	$I_C=0.1\text{A}, I_B=10\text{mA}$		10	15	mV
		$I_C=1\text{A}, I_B=10\text{mA}$		70	150	mV
		$I_C=2.5\text{A}, I_B=50\text{mA}$		200	250	mV
Base-Emitter Saturation Voltage (Note)	$V_{BE(SAT)}$	$I_C=2.5\text{A}, I_B=50\text{mA}$		0.89	1.0	V
Base-Emitter Turn-On Voltage (Note)	$V_{BE(ON)}$	$V_{CE}=2\text{V}, I_C=2.5\text{A}$		0.79	1.0	V
DC Current Gain (Note)	$h_{FE}$	$V_{CE}=2\text{V}, I_C=10\text{mA}$	200	400		
		$V_{CE}=2\text{V}, I_C=200\text{mA}$	300	450		
		$V_{CE}=2\text{V}, I_C=2\text{A}$	200	360		
		$V_{CE}=2\text{V}, I_C=6\text{A}$	100	180		
Transition Frequency	$f_T$	$V_{CE}=10\text{V}, I_C=50\text{mA}, f=100\text{MHz}$	100	140		MHz
Output Capacitance	$C_{OB}$	$V_{CB}=10\text{V}, f=1\text{MHz}$		23	30	pF
Turn-On Time	$t_{(ON)}$	$V_{CC}=10\text{V}, I_C=1\text{A}, I_{B1}=-I_{B2}=10\text{mA}$		170		nS
Turn-Off Time	$t_{(OFF)}$			400		nS

Note: Pulse width=300ms. Duty cycle  $\leq 2\%$

### TYPICAL CHARACTERISTICS ( $T_A=25^\circ\text{C}$ )

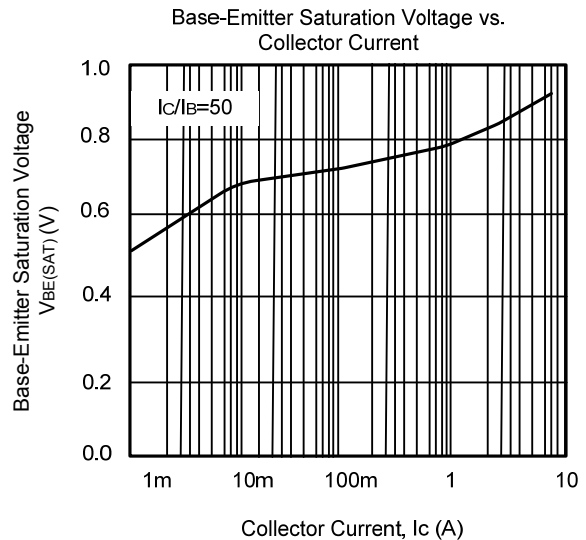
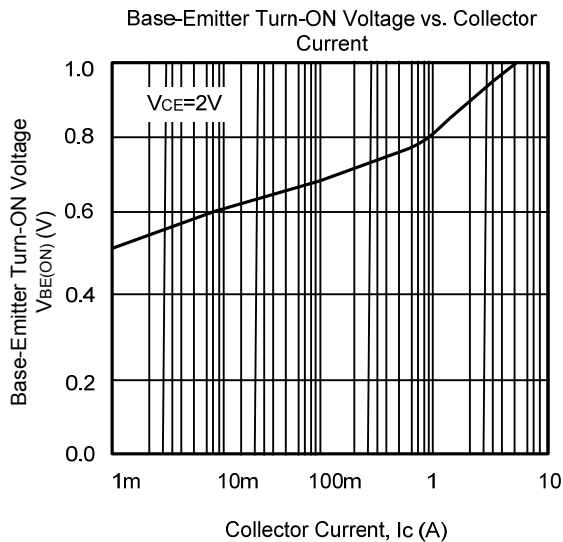
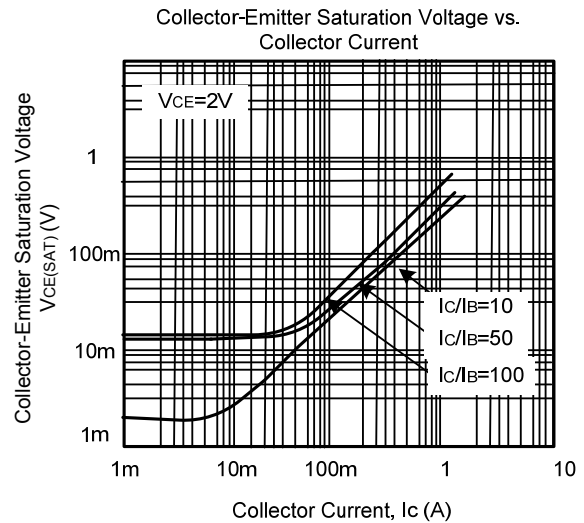
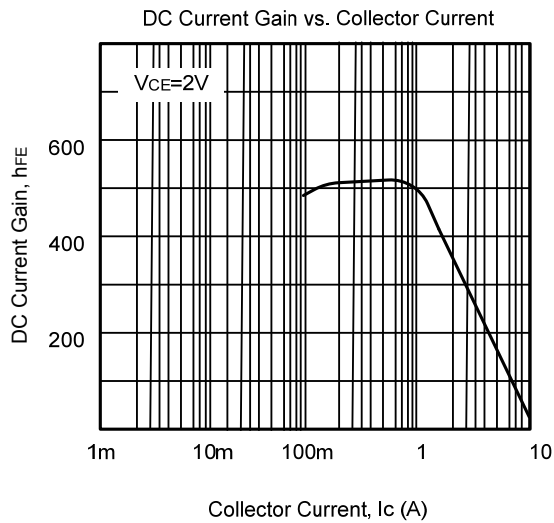

UTC assumes no responsibility for equipment failures that result from using products at values that exceed, even momentarily, rated values (such as maximum ratings, operating condition ranges, or other parameters) listed in products specifications of any and all UTC products described or contained herein. UTC products are not designed for use in life support appliances, devices or systems where malfunction of these products can be reasonably expected to result in personal injury. Reproduction in whole or in part is prohibited without the prior written consent of the copyright owner. The information presented in this document does not form part of any quotation or contract, is believed to be accurate and reliable and may be changed without notice.