



MJD210

PNP SILICON TRANSISTOR

PNP SILICON DPAK FOR SURFACE MOUNT APPLICATIONS

DESCRIPTION

The UTC MJD210 is designed for low voltage, low-power, high-gain audio amplifier applications.

FEATURE

- *Collector-Emitter Sustaining Voltage
 $V_{CE(SUS)} = -25V$ (Min) @ $I_C = -10mA$
- *High DC Current Gain
 $h_{FE} = 70$ (Min) @ $I_C = -500mA$
 $= 45$ (Min) @ $I_C = -2A$
 $= 10$ (Min) @ $I_C = -5A$
- *Lead Formed for Surface Mount Applications in Plastic Sleeves (No Suffix)
- *Straight Lead Version in Plastic Sleeves ("-1" Suffix)
- *Lead Formed Version in 16mm Tape and Reel ("T4" Suffix)
- *Low Collector – Emitter Saturation Voltage
 $V_{CE(SAT)} = -0.3V$ (Max) @ $I_C = -500mA$
 $= -0.75V$ (Max) @ $I_C = -2.0 A$
- *High Current-Gain-Bandwidth Product
 $f_T = 65 MHz$ (Min) @ $I_C = -100 mA$
- *Annular Construction for Low Leakage
 $I_{CBO} = -100 nA$ @ Rated V_{CB}

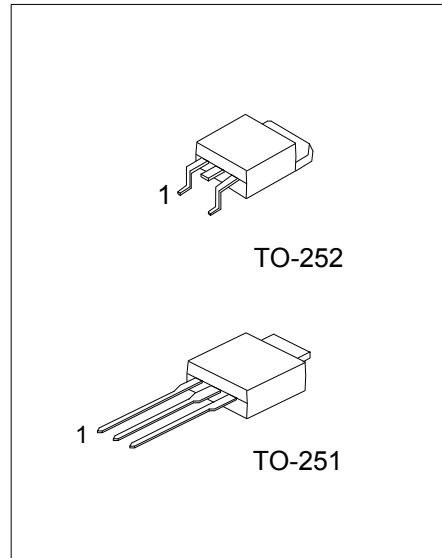

ORDERING INFORMATION

Ordering Number		Package	Pin Assignment			Packing
Lead Free Plating	Halogen Free		1	2	3	
MJD210L-TM3-T	MJD210G-TM3-T	TO-251	B	C	E	Tube
MJD210L-TN3-T	MJD210G-TN3-T	TO-252	B	C	E	Tube
MJD210L-TN3-R	MJD210G-TN3-R	TO-252	B	C	E	Tape Reel

<p>MJD210G-TM3-T</p> <p>(1) Packing Type</p> <p>(2) Package Type</p> <p>(3) Halogen Free</p>	<p>(1) T: Tube, R: Tape Reel</p> <p>(2) TM3: TO-251, TN3: TO-252</p> <p>(3) G: Halogen Free, L: Lead Free Plating</p>
--	---

■ ABSOLUTE MAXIMUM RATINGS (Ta=25°C, unless otherwise specified)

PARAMETER		SYMBOL	RATINGS	UNIT
Collector-Base Voltage		V _{CBO}	-40	V
Collector-Emitter Voltage		V _{CEO}	-25	V
Emitter-Base Voltage		V _{EBO}	-7	V
Collector Current	Continuous	I _C	-5	A
	Peak		-10	A
Base Current		I _B	-1	A
Total Device Dissipation	T _C =25°C	P _D	12.5	W
	Derate above 25°C		0.1	W/°C
	T _a =25°C (Note2)		1.4	W
	Derate above 25°C		0.011	W/°C
Junction Temperature		T _J	+150	°C
Storage Junction Temperature		T _{STG}	-65 ~ +150	°C

Note: 1. Absolute maximum ratings are those values beyond which the device could be permanently damaged.

Absolute maximum ratings are stress ratings only and functional device operation is not implied.

2. When surface mounted on minimum pad sizes recommended.

■ THERMAL DATA (Ta=25°C, unless otherwise specified)

PARAMETER	SYMBOL	RATING	UNIT
Junction to Ambient	θ _{JA}	89.3	°C/W
Junction to Case	θ _{JC}	10	°C/W

■ ELECTRICAL CHARACTERISTICS (Ta=25°C, unless otherwise specified)

PARAMETER	SYMBOL	TEST CONDITIONS	MIN	MAX	UNIT
OFF CHARACTERISTICS					
Collector-Emitter Sustaining Voltage(Note 1)	V _{CEO(SUS)}	I _C =-10mA, I _B =0	-25		V
Collector Cutoff Current	I _{CBO}	V _{CB} =-40V, I _E =0		-100	nA
		V _{CB} =-40V, I _E =0, T _J =125°C		-100	nA
Emitter Cutoff Current	I _{EBO}	V _{BE} =-7V, I _C =0		-100	nA
ON CHARACTERISTICS					
DC Current Gain (Note 1)	h _{FE}	I _C =-500mA, V _{CE} =-1V	70		
		I _C =-2A, V _{CE} =-1V	45	180	
		I _C =-5A, V _{CE} =-2V	10		
Collector-Emitter Saturation Voltage (Note 1)	V _{CE(SAT)}	I _C =-500mA, I _B =-50mA		-0.3	V
		I _C =-2A, I _B =-200mA		-0.75	
		I _C =-5A, I _B =-1A		-1.8	
Base-Emitter Saturation Voltage (Note 1)	V _{BE(SAT)}	I _C =-5A, I _B =-1A		-2.5	V
Base-Emitter On Voltage (Note 1)	V _{BE(ON)}	I _C =-2A, V _{CE} =-1V		-1.6	V
DYNAMIC CHARACTERISTICS					
Current-Gain-Bandwidth Product (Note 2)	f _T	I _C =-100mA, V _{CE} =-10V, f _{TEST} = 10MHz	65		MHz
Output Capacitance	C _{OB}	V _{CB} =-10V, I _E =0, f=0.1MHz		120	pF

Note: 1. Pulse Test: Pulse Width = 300μs, Duty Cycle ≈ 2%.

2. $f_T = |h_{FE}| \cdot f_{TEST}$.

TYPICAL CHARACTERISTICS

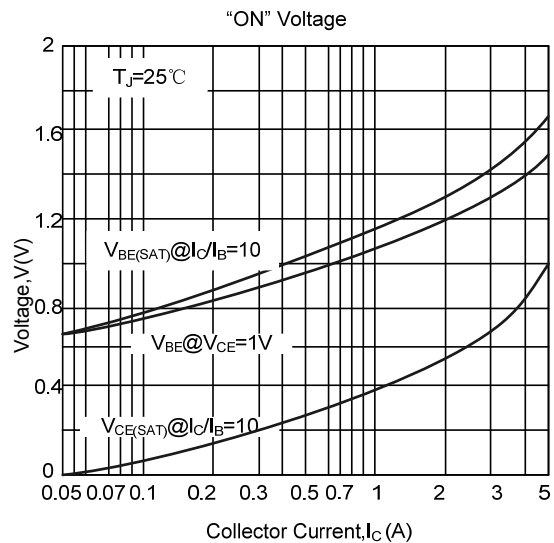
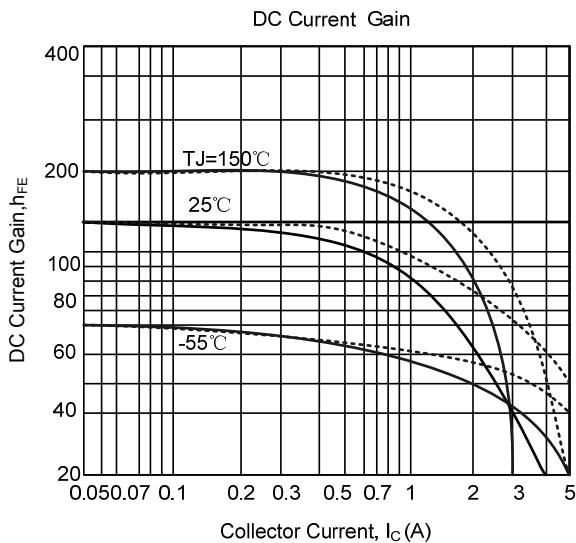
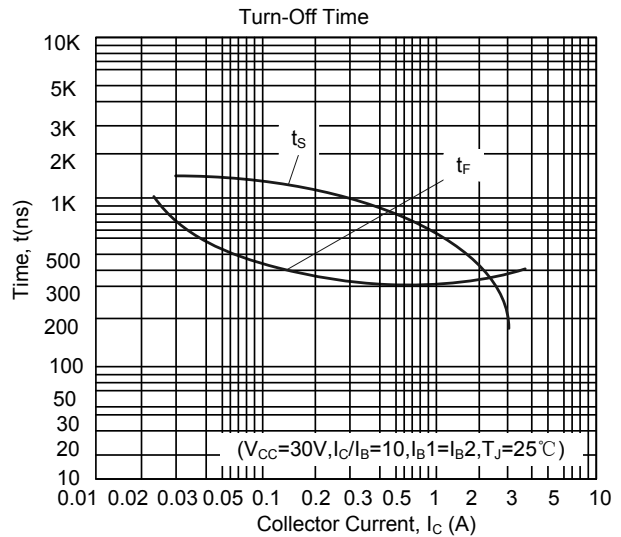
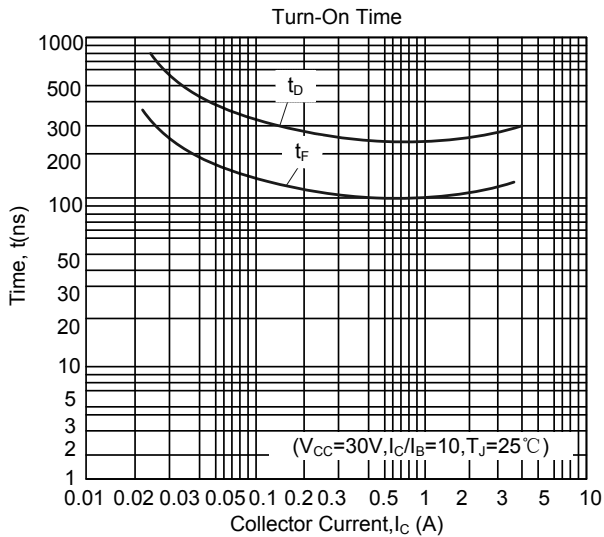
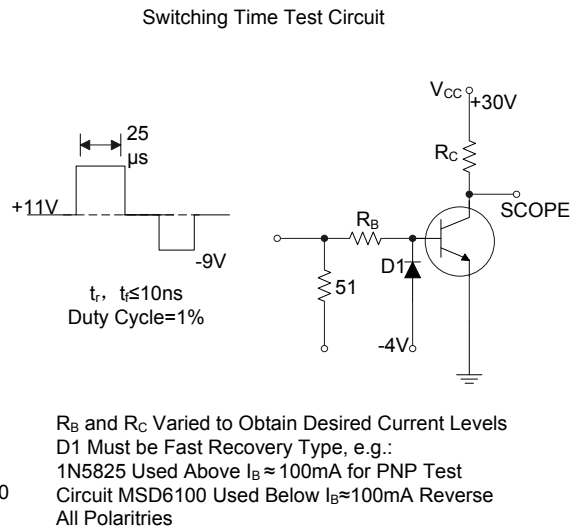
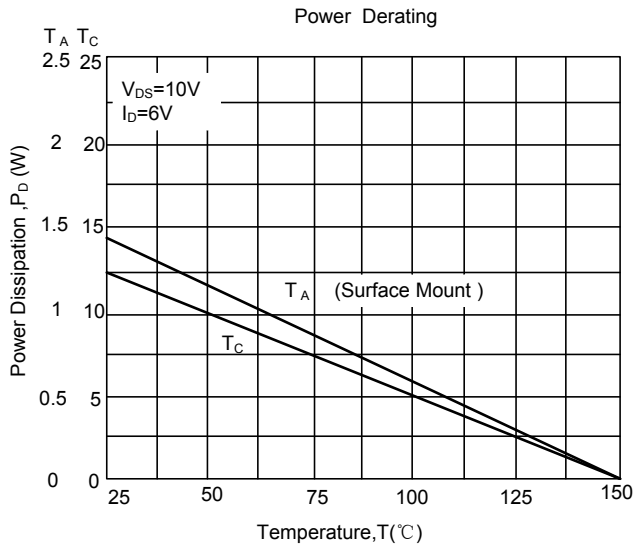

■ TYPICAL CHARACTERISTICS (Cont.)

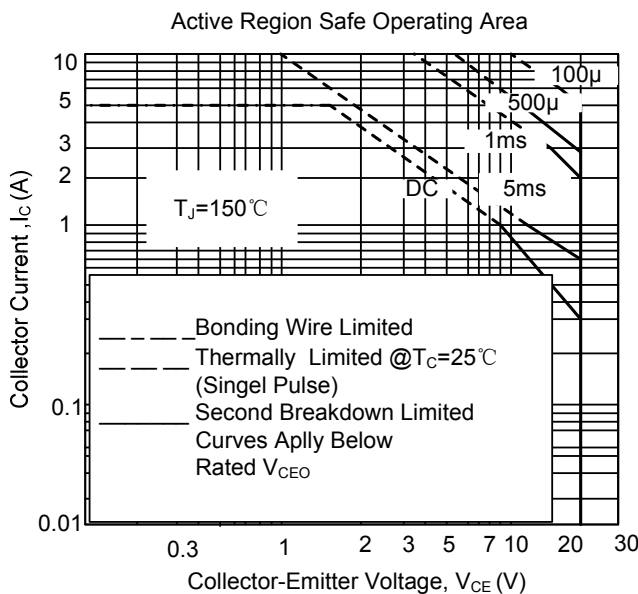
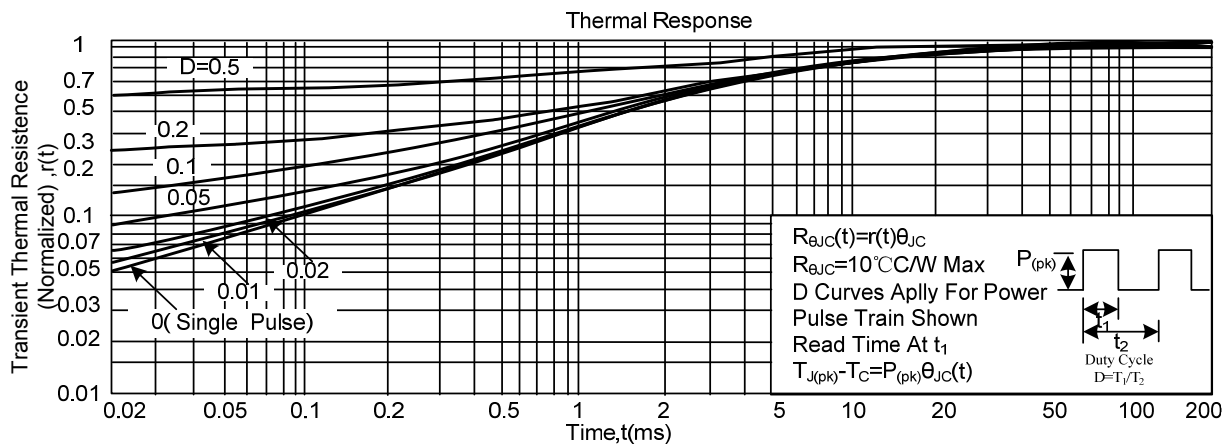
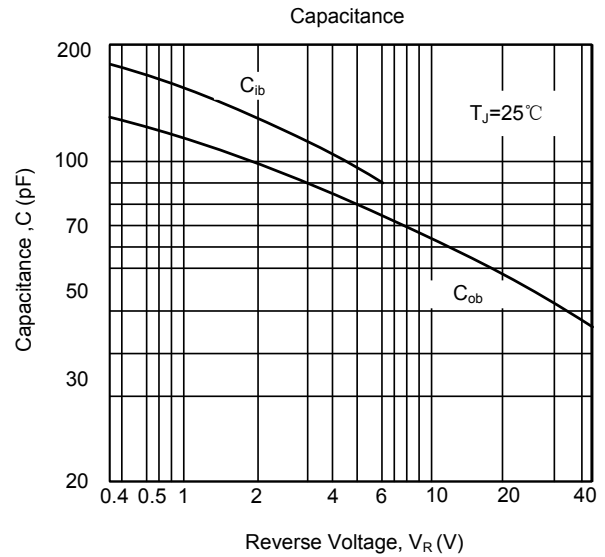
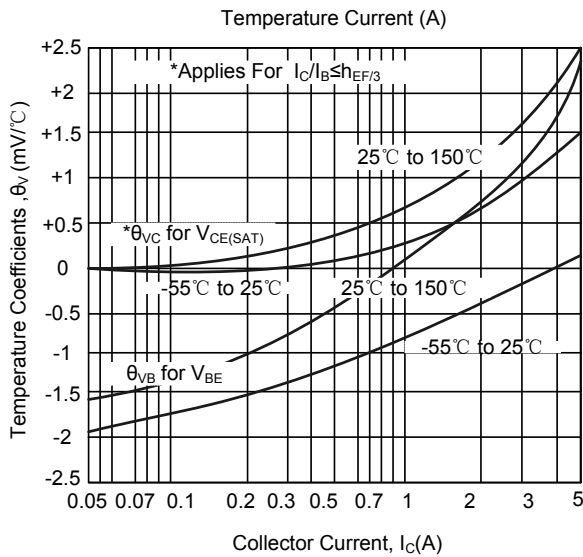

There are two limitations on the power handling ability of a transistor: average junction temperature and second breakdown. Safe operating area curves indicate I_C - V_{CE} limits of the transistor that must be observed for reliable operation; i.e., the transistor must not be subjected to greater dissipation than the curves indicate.

The data of Fig. 9 is based on $T_{J(pk)} = 150^\circ\text{C}$; T_C is variable depending on conditions. Second breakdown pulse limits are valid for duty cycles to 10% provided $T_{J(pk)} = 150^\circ\text{C}$. $T_{J(pk)}$ may be calculated from the data in Figure 8. At high case temperatures, thermal limitations will reduce the power that can be handled to values less than the limitations imposed by second breakdown.

UTC assumes no responsibility for equipment failures that result from using products at values that exceed, even momentarily, rated values (such as maximum ratings, operating condition ranges, or other parameters) listed in products specifications of any and all UTC products described or contained herein. UTC products are not designed for use in life support appliances, devices or systems where malfunction of these products can be reasonably expected to result in personal injury. Reproduction in whole or in part is prohibited without the prior written consent of the copyright owner. The information presented in this document does not form part of any quotation or contract, is believed to be accurate and reliable and may be changed without notice.