



# BC546/547/548

NPN EPITAXIAL SILICON TRANSISTOR

## SWITCHING AND AMPLIFIER APPLICATIONS

### FEATURES

- \* High Voltage: **UTC BC546**,  $V_{CE0}=65V$
- UTC BC547**,  $V_{CE0}=45V$
- UTC BC548**,  $V_{CE0}=30V$

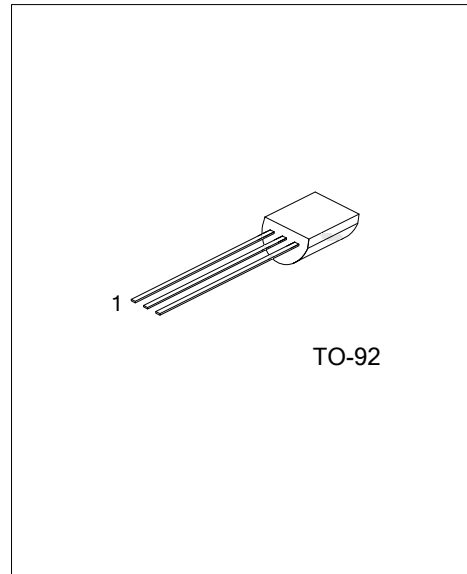

### ORDERING INFORMATION

Order Number		Package	Pin Assignment			Packing
Lead Free	Halogen Free		1	2	3	
BC546L-x-T92-B	BC546G-x-T92-B	TO-92	C	B	E	Tape Box
BC546L-x-T92-K	BC546G-x-T92-K	TO-92	C	B	E	Bulk
BC547L-x-T92-B	BC547G-x-T92-B	TO-92	C	B	E	Tape Box
BC547L-x-T92-K	BC547G-x-T92-K	TO-92	C	B	E	Bulk
BC548L-x-T92-B	BC548G-x-T92-B	TO-92	C	B	E	Tape Box
BC548L-x-T92-K	BC548G-x-T92-K	TO-92	C	B	E	Bulk

Note: Pin Assignment: C: Collector B: Base E: Emitter

<p>BC546L-x-T92-B</p> <p>(1) Packing Type</p> <p>(2) Package Type</p> <p>(3) Rank</p> <p>(4) Halogen Free</p>	<p>(1) B: Tape Box, K: Bulk</p> <p>(2) T92: TO-92</p> <p>(3) refer to CLASSIFICATION OF <math>h_{FE}</math></p> <p>(4) L: Lead Free, G: Halogen Free</p>
---	--

■ **ABSOLUTE MAXIMUM RATING** ( $T_A=25^\circ\text{C}$ , unless otherwise specified)

PARAMETER	SYMBOL	RATINGS	UNIT
Collector-base voltage	BC546	80	V
	BC547	50	V
	BC548	30	V
Collector-emitter voltage	BC546	65	V
	BC547	45	V
	BC548	30	V
Emitter-base voltage	BC546	6	V
	BC547	6	V
	BC548	5	V
Collector current (DC)	$I_C$	100	mA
Collector dissipation	$P_C$	500	mW
Junction Temperature	$T_J$	150	$^\circ\text{C}$
Storage Temperature	$T_{STG}$	-55 ~ +150	$^\circ\text{C}$

Note: Absolute maximum ratings are those values beyond which the device could be permanently damaged.

Absolute maximum ratings are stress ratings only and functional device operation is not implied.

■ **ELECTRICAL CHARACTERISTICS** ( $T_A=25^\circ\text{C}$ , unless otherwise specified)

PARAMETER	SYMBOL	TEST CONDITIONS	MIN	TYP	MAX	UNIT
Collector Cut-off Current	$I_{CBO}$	$V_{CB}=30\text{V}, I_E=0$			15	nA
DC current gain	$h_{FE}$	$V_{CE}=5\text{V}, I_C=2\text{mA}$	110		800	
Collector-emitter saturation voltage	$V_{CE(SAT)}$	$I_C=10\text{mA}, I_B=0.5\text{mA}$		90	250	mV
		$I_C=100\text{mA}, I_B=5\text{mA}$		200	600	mV
Base-emitter saturation voltage	$V_{BE(SAT)}$	$I_C=10\text{mA}, I_B=0.5\text{mA}$		700		mV
		$I_C=100\text{mA}, I_B=5\text{mA}$		900		mV
Base-emitter on voltage	$V_{BE(ON)}$	$V_{CE}=5\text{V}, I_C=2\text{mA}$	580	660	700	mV
		$V_{CE}=5\text{V}, I_C=10\text{mA}$			720	mV
Current gain bandwidth product	$f_T$	$V_{CE}=5\text{V}, I_C=10\text{mA}, f=100\text{MHz}$		300		MHz
Output Capacitance	$C_{ob}$	$V_{CB}=10\text{V}, I_E=0, f=1\text{MHz}$		3.5	6	pF
Input Capacitance	$C_{ib}$	$V_{EB}=0.5\text{V}, I_C=0, f=1\text{MHz}$		9		pF
Noise Figure	NF	$V_{CE}=5\text{V}, I_C=200\mu\text{A}, f=1\text{KHz}, R_G=2\text{K}\Omega$		2	10	dB

■ **CLASSIFICATION OF  $h_{FE}$**

RANK	A	B	C
$h_{FE}$	110 - 220	200 - 450	420 - 800

## ■ TYPICAL CHARACTERISTICS

Figure 1. Static Characteristic

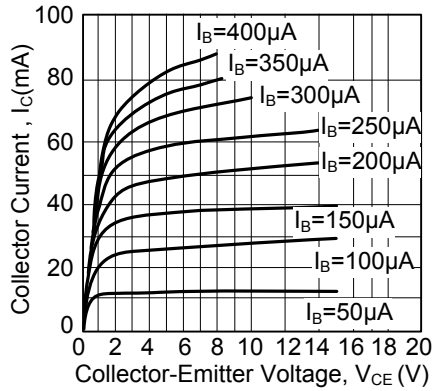

Figure 2. Transfer Characteristic

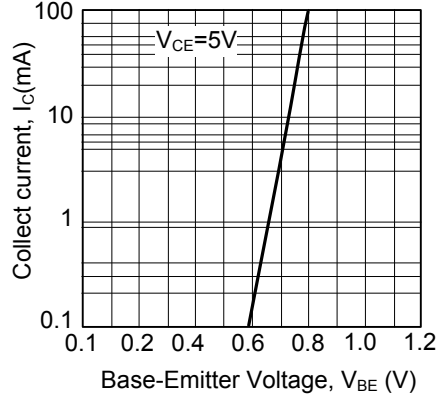

Figure 3. DC Current Gain

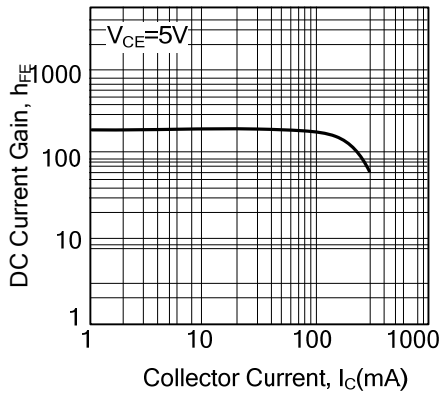

Figure 4. Base-Emitter Saturation Voltage  
Collector-Emitter Saturation Voltage

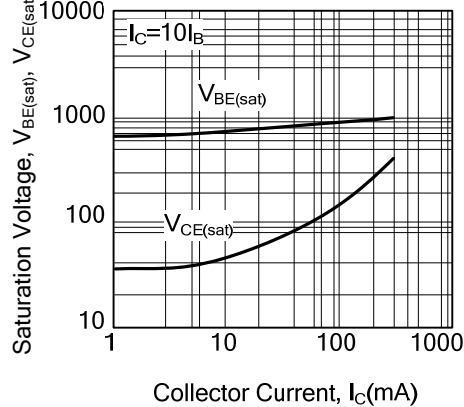

Figure 5. Output Capacitance

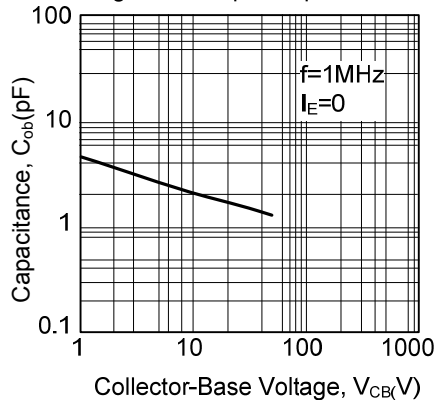
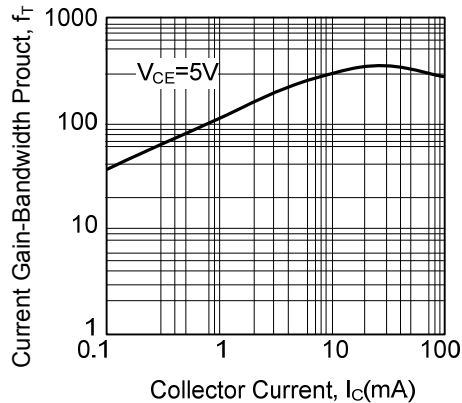

Figure 6. Current Gain Bandwidth Product



UTC assumes no responsibility for equipment failures that result from using products at values that exceed, even momentarily, rated values (such as maximum ratings, operating condition ranges, or other parameters) listed in products specifications of any and all UTC products described or contained herein. UTC products are not designed for use in life support appliances, devices or systems where malfunction of these products can be reasonably expected to result in personal injury. Reproduction in whole or in part is prohibited without the prior written consent of the copyright owner. The information presented in this document does not form part of any quotation or contract, is believed to be accurate and reliable and may be changed without notice.