



UCR16CM/A

TRIAC

TRIAC

DESCRIPTION

The **UCR16CM/A** is isolated, glass passivation type triac in full plastic TO-220F package for medium power use.

FEATURES

- * Repetitive Peak off-State Voltage: $V_{DRM} = 400, 600V$
- * R.M.S On-State Current: $I_T (RMS) = 16A$
- * High Commutating (dv / dt)

APPLICATIONS

- * Light Dimmer and Electric Flasher Unit.
- * Household Electrical Equipment Control.
- * Small Motor Control.
- * Copy Machine.
- * General Purpose Control Applications.

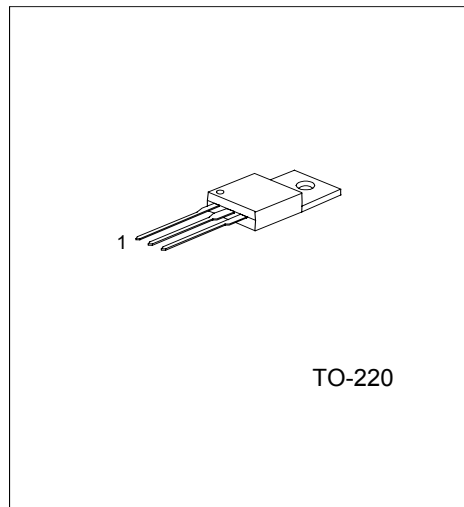

*Pb-free plating product number:
UCR16CML/UCR16CMAL

PIN CONFIGURATION

PIN	PIN NAME	DESCRIPTION
1	MT1	Terminal 1
2	MT2	Terminal 2
3	Gate	Gate Terminal

ORDERING INFORMATION

Ordering Number		Package	Packing
Normal	Lead free		
UCR16CM-TA3-T	UCR16CML-TA3-T	TO-220	Tube
UCR16CMA-TA3-T	UCR16CMAL-TA3-T		

■ ABSOLUTE MAXIMUM RATINGS

PARAMETER		SYMBOL	RATINGS	UNIT
Repetitive Peak Off-State Voltage ^{Note *}	UCR16CM-4 UCR16CMA-4	V_{DRM}	400	V
	UCR16CM-6 UCR16CMA-6		600	
Non-Repetitive Peak Off-State Voltage ^{Note *}	UCR16CM-4 UCR16CMA-4	V_{DSM}	500	V
	UCR16CM-6 UCR16CMA-6		720	
RMS On-State Current (Commercial Frequency, Full Sine Waveform $T_c=100^\circ\text{C}$)		$I_{T(RMS)}$	16	A
Peak One Cycle Surge On-State Current (Non-Repetitive)	50Hz	I_{TSM}	155	A
	60Hz		170	
I^2t Limit Value		I^2t	121	A^2s
Peak Gate Power Dissipation		P_{GM}	5	W
Average Gate Power Dissipation		$P_{G(AV)}$	0.5	W
Peak Gate Voltage		V_{GM}	10	V
Peak Gate Current		I_{GM}	2	A
Junction Temperature		T_j	125	$^\circ\text{C}$
Storage Temperature		T_{STG}	-40 ~ +150	$^\circ\text{C}$

Note: * Gate Open.

■ ELECTRICAL CHARACTERISTICS ($T_a=25^\circ\text{C}$, unless otherwise specified)

PARAMETER		SYMBOL	TEST CONDITIONS	MIN	TYP	MAX	UNIT			
Gate Trigger Voltage	I	V_{GT}	$V_D=6\text{V}$ $R_L=6\Omega$	MT2 (+), Gate (+)		1.5	V			
	II							MT2 (+), Gate (-)	1.5	
	III							MT2 (-), Gate (-)	1.5	
	IV							MT2 (-), Gate (+)	-	
Gate Trigger Current	UCR16CM	I_{GT}	$V_D=6\text{V}$ $R_L=6\Omega$	MT2 (+), Gate (+)		30	mA			
								II	MT2 (+), Gate (-)	30
								III	MT2 (-), Gate (-)	30
								IV	MT2 (-), Gate (+)	-
	UCR16CMA							I	MT2 (+), Gate (+)	20
								II	MT2 (+), Gate (-)	20
								III	MT2 (-), Gate (-)	20
								IV	MT2 (-), Gate (+)	
Peak On-State Voltage		V_{TM}	$I_{TM}=25\text{A}$			1.5	V			
Gate Non-Trigger Voltage		V_{GD}	$T_j=125^\circ\text{C}$, $V_D=1/2V_{DRM}$	0.2			V			
Repetitive Peak Off-State Current		I_{DRM}	V_{DRM} Applied			2	mA			
Holding Current		I_H	$V_D=12\text{V}$, $I_{TM}=1\text{A}$		25	50	mA			
Critical Rate of Rise of Off-State Voltage	UCR16CM	dv / dt	$V_{DRM} = \text{Rated}$, $T_j = 125^\circ\text{C}$ Exponential Rise		300		V/ μs			
	UCR16CMA							200		
Critical Rate of Rise of Off-State Voltage at Commutation	UCR16CM	(dv / dt) c	$V_{DRM} = 400\text{V}$, $T_j = 125^\circ\text{C}$ (di / dt) c = -8A / ms		10		V/ μs			
	UCR16CMA							4		

■ THERMAL DATA

PARAMETER	SYMBOL	RATINGS	UNIT
Thermal Resistance Junction to Case	TO-220F θ_{Jc}	3	$^\circ\text{C}/\text{W}$

■ TEST CIRCUITS

GATE TRIGGER CHARACTERISTICS

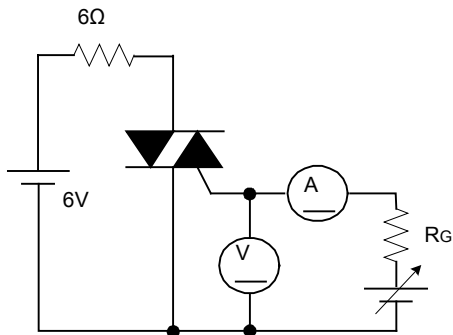

TEST PROCEDURE I

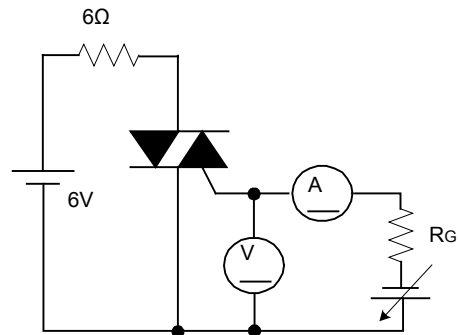

TEST PROCEDURE II

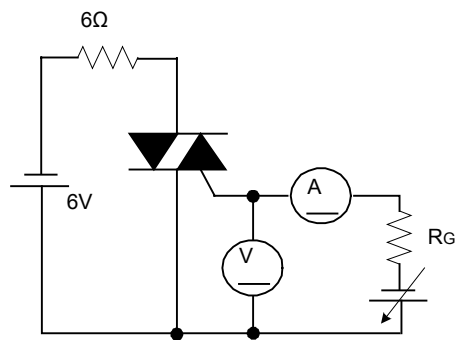

TEST PROCEDURE III

TYPICAL CHARACTERISTICS

GATE TRIGGER CHARACTERISTICS

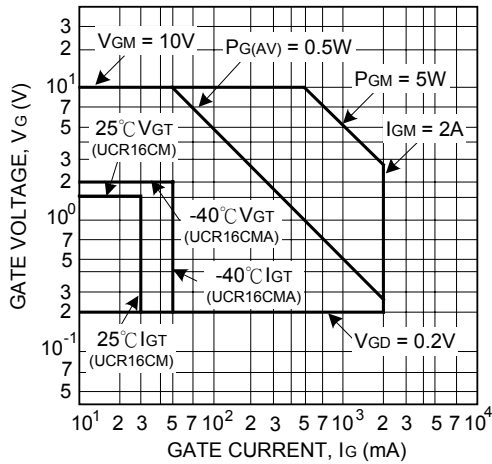

RATED SURGE ON-STATE CURRENT

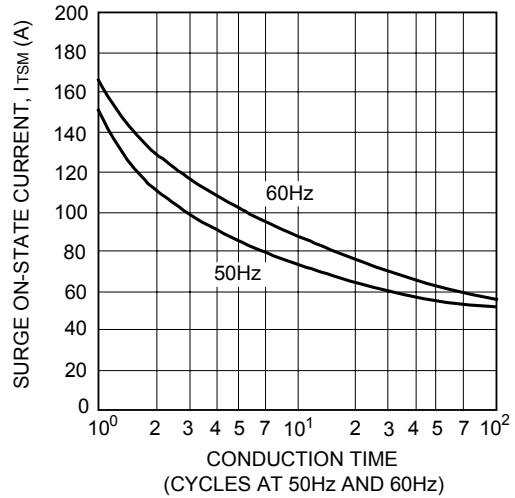

MAXIMUM ON-STATE CHARACTERISTICS

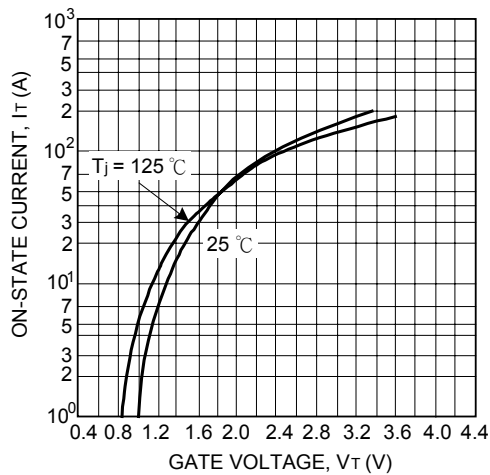

MAXIMUM ON-STATE POWER DISSIPATION

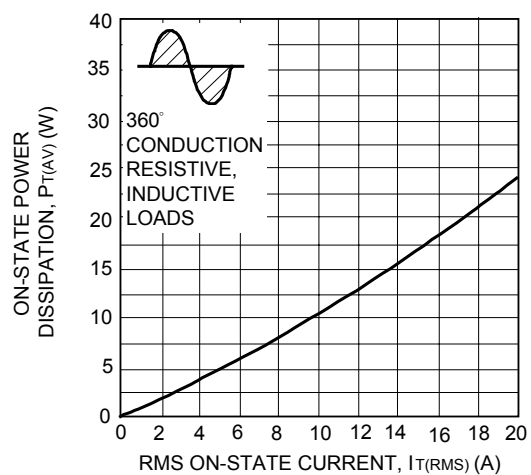

ALLOWABLE CASE TEMPERATURE VS. RMS ON-STATE CURRENT

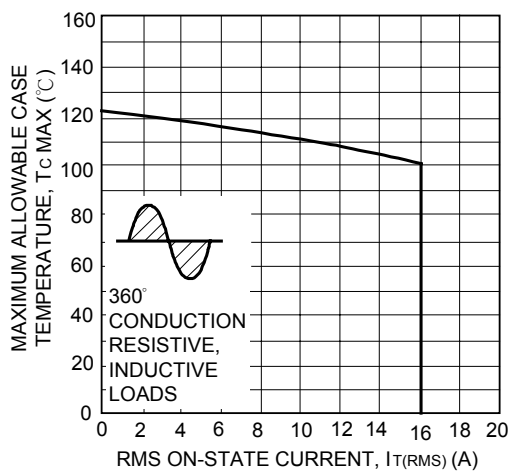

ALLOWABLE AMBIENT TEMPERATURE VS. RMS ON-STATE CURRENT

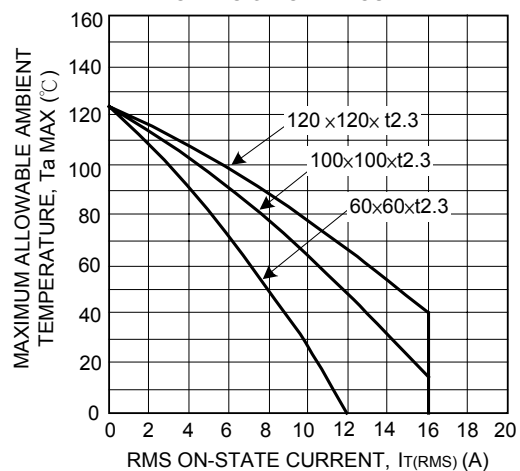

■ TYPICAL CHARACTERISTICS(Cont.)

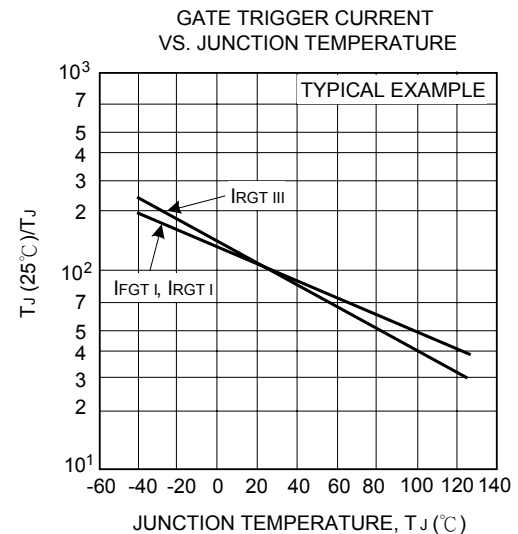
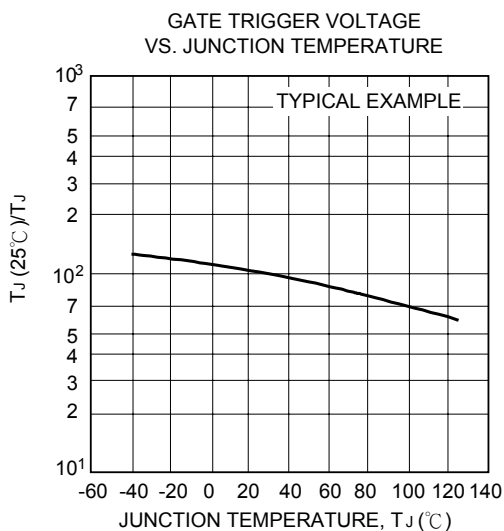
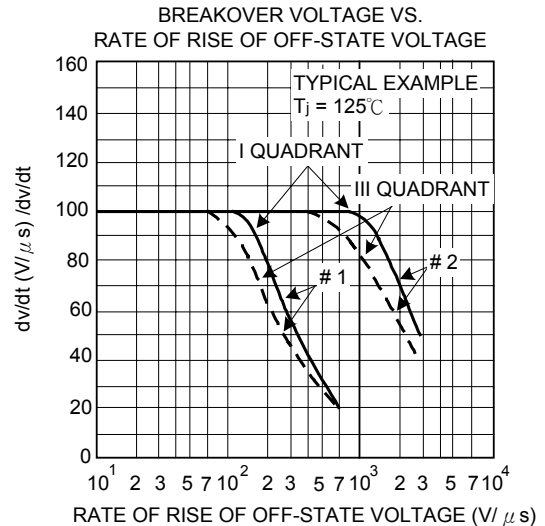
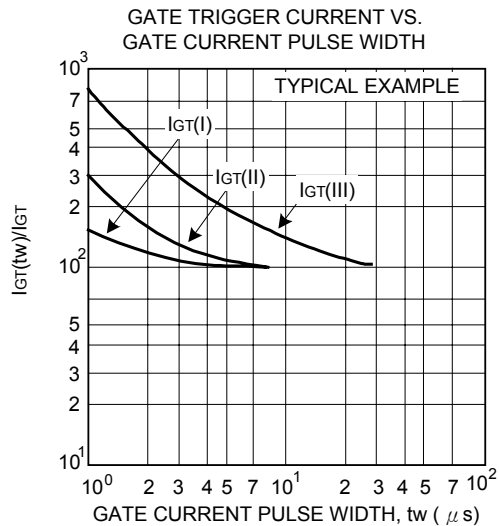
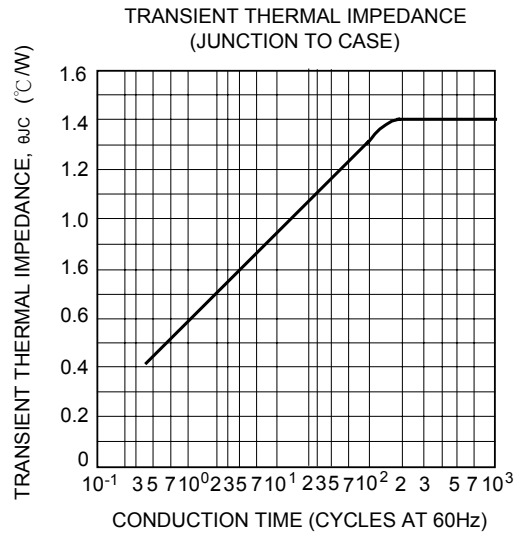
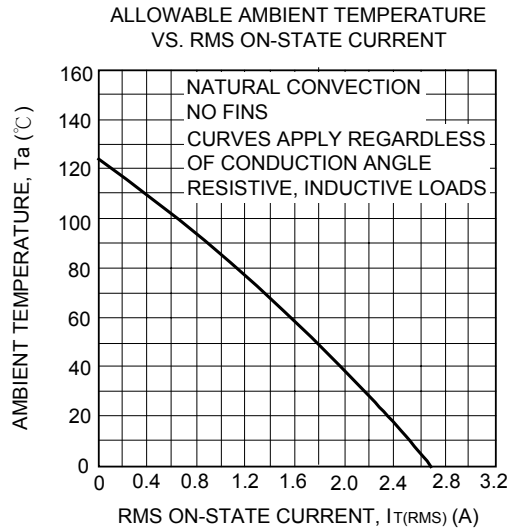

■ TYPICAL CHARACTERISTICS(Cont.)

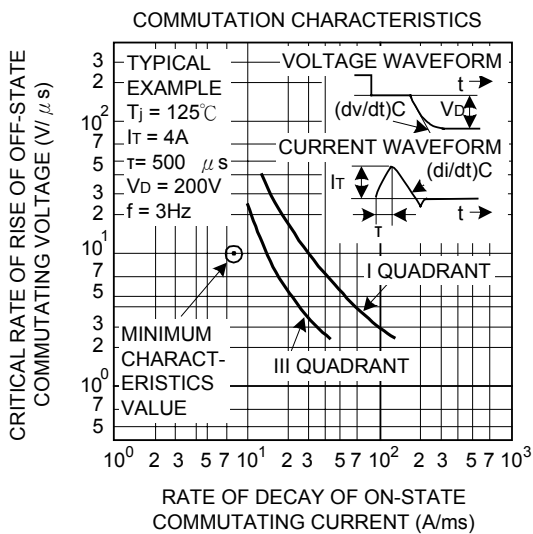
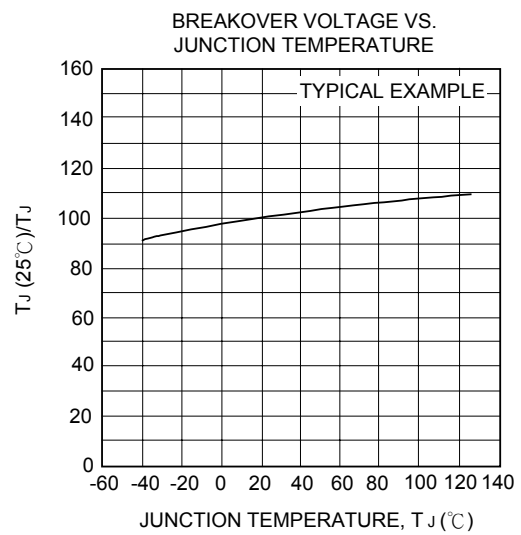
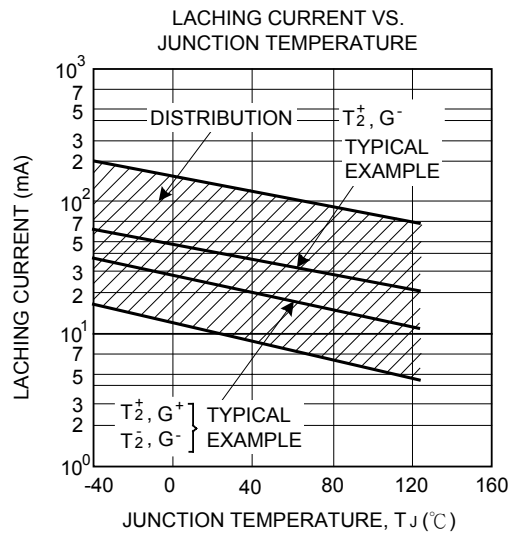
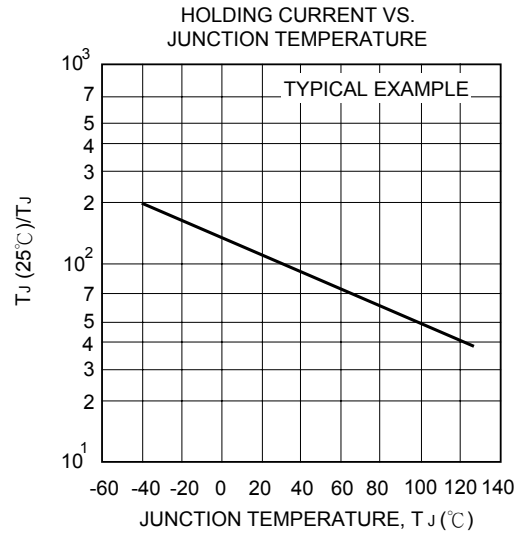
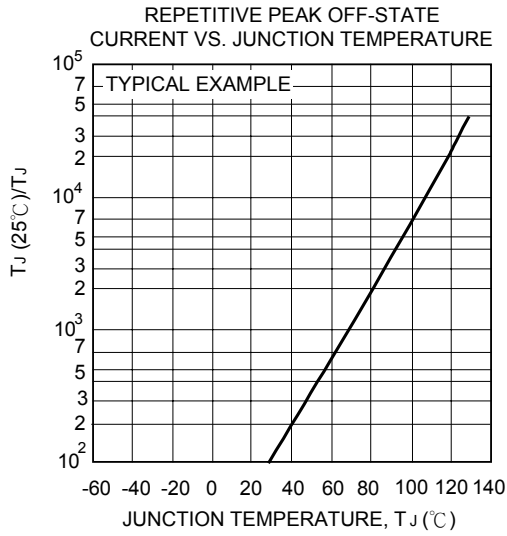

UTC assumes no responsibility for equipment failures that result from using products at values that exceed, even momentarily, rated values (such as maximum ratings, operating condition ranges, or other parameters) listed in products specifications of any and all UTC products described or contained herein. UTC products are not designed for use in life support appliances, devices or systems where malfunction of these products can be reasonably expected to result in personal injury. Reproduction in whole or in part is prohibited without the prior written consent of the copyright owner. The information presented in this document does not form part of any quotation or contract, is believed to be accurate and reliable and may be changed without notice.