



U12JZ47/A

TRIAC

HIGH COMMUTATING TRIAC

DESCRIPTION

The **U12JZ47/A** is a bi-directional, silicon planar type triac in full plastic pack for AC power control applications.

FEATURES

- * Repetitive Peak off-State Voltage: $V_{DRM} = 400, 600V$
- * R.M.S On-State Current: $I_{T(RMS)} = 12A$
- * High Commutating (dv / dt)
- * Isolation Voltage: $V_{isol} = 1500V AC$

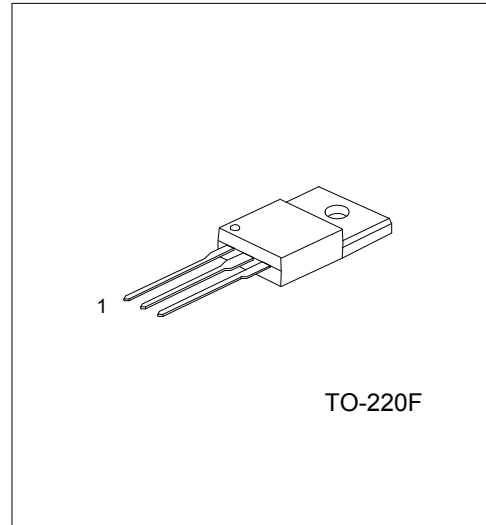

ORDERING INFORMATION

Ordering Number		Package	Pin Assignment			Packing
Lead Free	Halogen Free		1	2	3	
U12JZ47L-x-TF3-T	U12JZ47G-x-TF3-T	TO-220F	MT1	MT2	G	Tube
U12JZ47AL-x-TF3-T	U12JZ47AG-x-TF3-T	TO-220F	MT1	MT2	G	Tube

Note: Pin Assignment: MT1: Terminal 1, MT2: Terminal 2, G: Gate

<p>U12JZ47AL-x-TF3-T</p> <ul style="list-style-type: none"> (1) Packing Type (2) Package Type (3) V_{DRM} (4) Lead Free (5) Gate Trigger Current 	<ul style="list-style-type: none"> (1) R: Tape Reel, T: Tube (2) TF3: TO-220F (3) 4: 400V, 6: 600V (4) G: Halogen Free, L: Lead Free (5) A: refer to I_{GT}
--	---

■ ABSOLUTE MAXIMUM RATINGS

PARAMETER		SYMBOL	RATINGS	UNIT
Repetitive Peak Off-State Voltage and Repetitive Peak Reverse Voltage	U12JZ47-4	V_{DRM}	400	V
	U12JZ47A-4			
	U12JZ47-6		600	
	U12JZ47A-6			
RMS On-State Current (Commercial Frequency, Full Sine Waveform $T_C = 72^\circ\text{C}$)		$I_{T(RMS)}$	12	A
Peak One Cycle Surge On-State Current (Non-Repetitive)	50Hz	I_{TSM}	120	A
	60Hz		132	
I^2t Limit Value		I^2t	72	A^2s
Critical Rate of Rise of On-State Current (Note *)		di / dt	50	$\text{A}/\mu\text{s}$
Peak Gate Power Dissipation		P_{GM}	5	W
Average Gate Power Dissipation		$P_{G(AV)}$	0.5	V
Peak Gate Voltage		V_{GM}	10	V
Peak Gate Current		I_{GM}	2	A
Junction Temperature		T_J	125	$^\circ\text{C}$
Storage Temperature Range		T_{STG}	-40 ~ +150	$^\circ\text{C}$
Isolation Voltage (AC, t = 1min.)		V_{Isol}	1500	V

Note: * di/dt test condition $V_{DRM}=0.5 \times \text{Rated}$, $I_{TM} \leq 17\text{A}$, $t_{GW} \geq 10\mu\text{s}$, $t_{GR} \leq 250\text{ns}$, $I_{GP}=I_{GT} \times 2.0$.

■ THERMAL DATA

PARAMETER	SYMBOL	RATINGS	UNIT
Thermal Resistance Junction to Case	θ_{JC}	3	$^\circ\text{C}/\text{W}$

■ ELECTRICAL CHARACTERISTICS ($T_A = 25^\circ\text{C}$, unless otherwise specified)

PARAMETER		SYMBOL	TEST CONDITIONS	MIN	TYP	MAX	UNIT	
Gate Trigger Voltage	I	V_{GT}	$V_D = 12\text{V}$ $R_L = 20\Omega$			1.5	V	
	II					1.5		
	III					1.5		
	IV							
Gate Trigger Current	U12JZ47	I_{GT}	$V_D = 12\text{V}$ $R_L = 20\Omega$			30	mA	
						II		30
						III		30
						IV		
	U12JZ47A					I		20
						II		20
						III		20
						IV		
Peak On-State Voltage		V_{TM}	$I_{TM} = 17\text{A}$			1.5	V	
Gate Non-Trigger Voltage		V_{GD}	$V_D = \text{Rated}$, $T_C = 125^\circ\text{C}$	0.2			V	
Repetitive Peak Off-State Current		I_{DRM}	$V_{DRM} = \text{Rated}$			20	μA	
Holding Current		I_H	$V_D = 12\text{V}$, $I_{TM} = 1\text{A}$			50	mA	
Critical Rate of Rise of Off-State Voltage	U12JZ47	dv / dt	$V_{DRM} = \text{Rated}$, $T_J = 125^\circ\text{C}$ Exponential Rise		300		$\text{V}/\mu\text{s}$	
	U12JZ47A				200			
Critical Rate of Rise of Off-State Voltage at Commutation	U12JZ47	$(dv / dt)_c$	$V_{DRM} = 400\text{V}$, $T_J = 125^\circ\text{C}$ $(di / dt)_c = -6.5\text{A} / \text{ms}$		10		$\text{V}/\mu\text{s}$	
	U12JZ47A				4			

■ TYPICAL CHARACTERISTICS

GATE TRIGGER CHARACTERISTIC

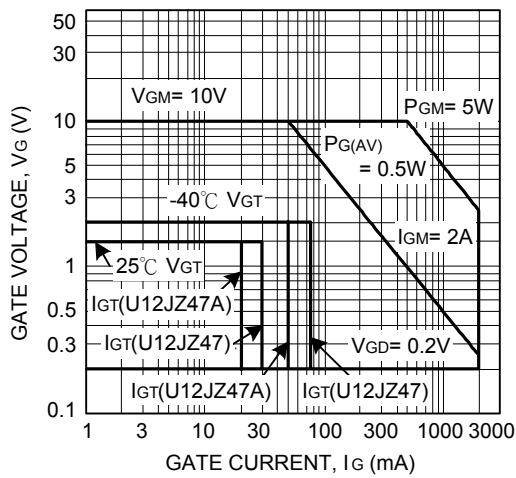

RATED SURGE ON - STATE CURRENT

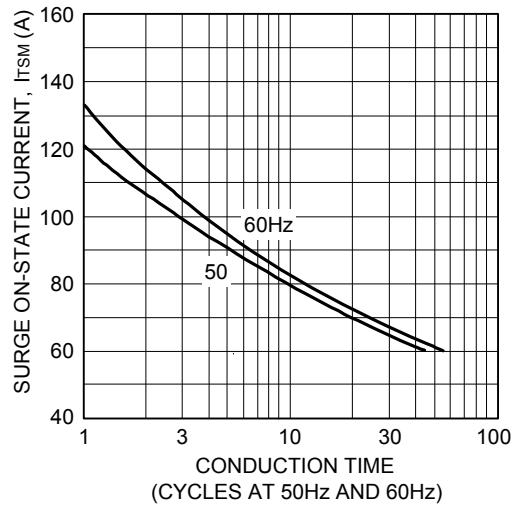

MAXIMUM ON-STATE CHARACTERISTICS

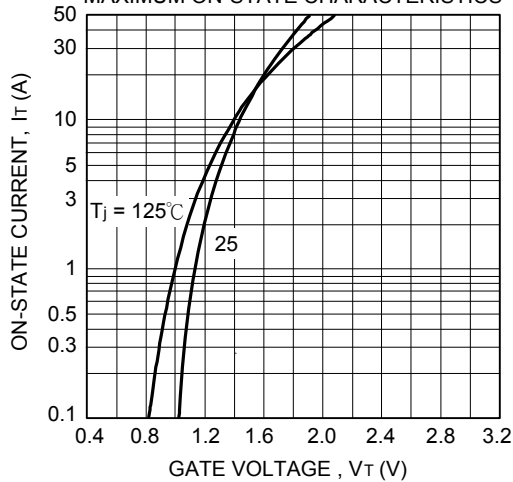

MAXIMUM ON-STATE POWER DISSIPATION

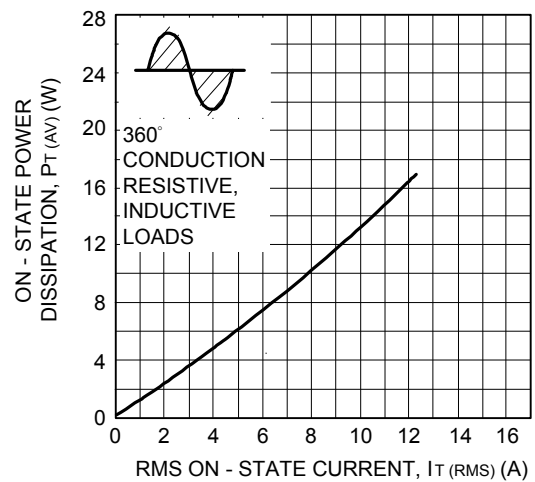

ALLOWABLE CASE TEMPERATURE VS. RMS ON-STATE CURRENT

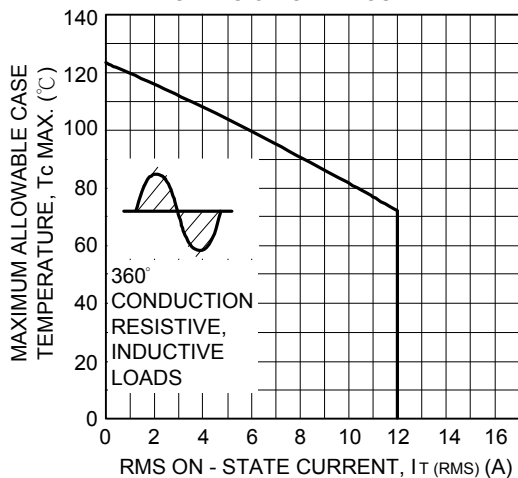

ALLOWABLE AMBIENT TEMPERATURE VS. RMS ON-STATE CURRENT

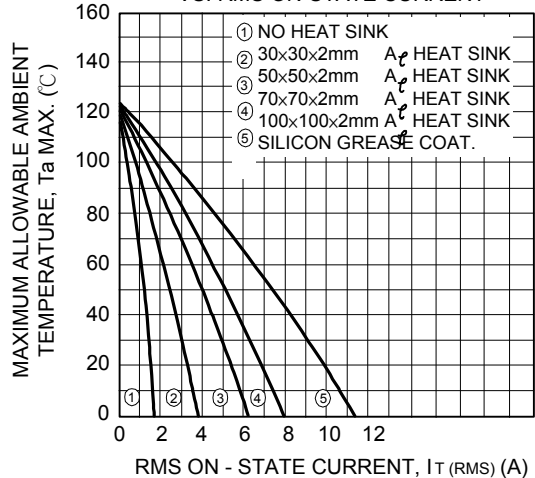

■ TYPICAL CHARACTERISTICS (Cont.)

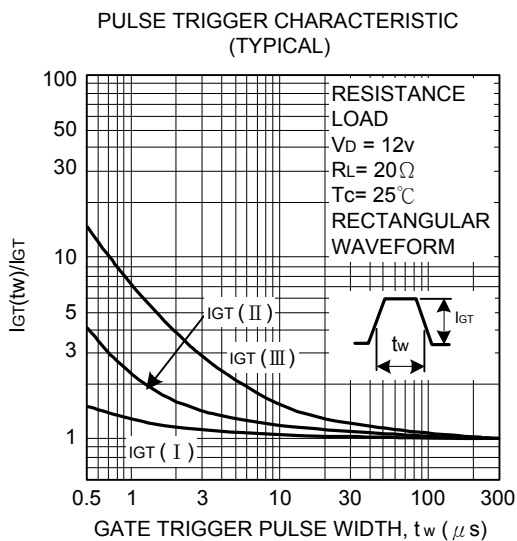
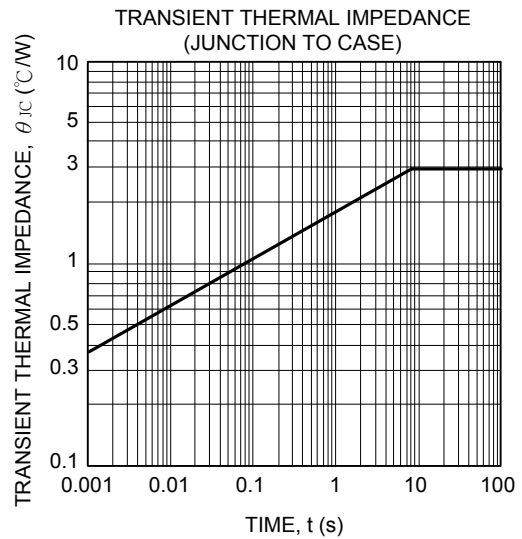
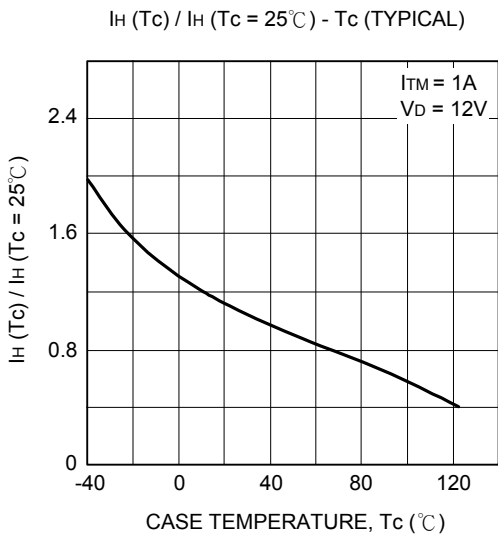
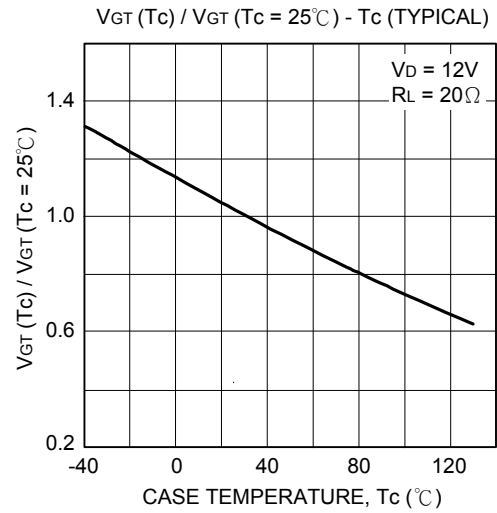
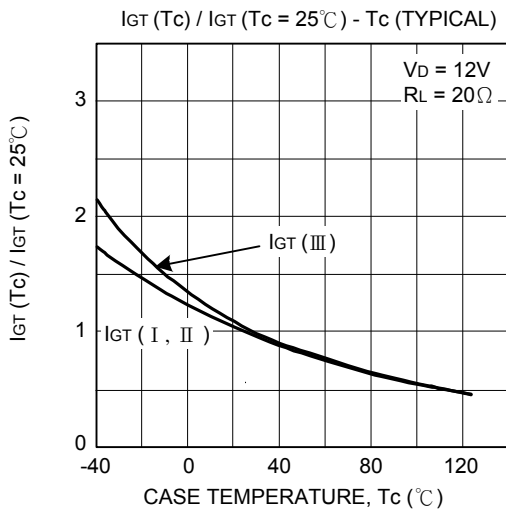

UTC assumes no responsibility for equipment failures that result from using products at values that exceed, even momentarily, rated values (such as maximum ratings, operating condition ranges, or other parameters) listed in products specifications of any and all UTC products described or contained herein. UTC products are not designed for use in life support appliances, devices or systems where malfunction of these products can be reasonably expected to result in personal injury. Reproduction in whole or in part is prohibited without the prior written consent of the copyright owner. The information presented in this document does not form part of any quotation or contract, is believed to be accurate and reliable and may be changed without notice.